

DESCRIPTION: 25W Wide Input Voltage DC/DC Converters



The rated output power of TP25DG converters is 25W, the outline dimensions is 50.8x50.8x11.2, 2:1 and 4:1 wide input voltage range, the voltage range is 9V-18V,18V-36V,36V-72V,9V-36V and 18V-72VDC.The accuracy of the converter can reach $\pm 1\%$, it can be widely used in telecommunications, railway transportation, instrument and etc.

FEATURES

25W output power	2:1&4:1 input voltage range	Over current protection
50.8mm*50.8mm*11.2mm standard package	Fixed switching frequency	Super capability with capacitive load
Metal shielding package	Input under voltage protection	Operating temperature :-25°C to 55°C
RoHs compliance	/	/

SELECTION GUIDE

Part Number	Input Voltage voltage (VDC)		Output		Efficiency(Typ.) %
	Rated	Range values	Voltage (VDC)	Current (A)	
TP25DG12S03	12(2:1)	9-18	3.3	5	86
TP25DG12S05	12(2:1)	9-18	5	5	83
TP25DG12S12	12(2:1)	9-18	12	2.1	86
TP25DG12S15	12(2:1)	9-18	15	1.67	86
TP25DG12S24	12(2:1)	9-18	24	1.04	85
TP25DG12D05	12(2:1)	9-18	± 5	± 2.5	83
TP25DG12D12	12(2:1)	9-18	± 12	± 1.04	86
TP25DG12D15	12(2:1)	9-18	± 15	± 0.83	86
TP25DG24S03	24(2:1)	18-36	3.3	5	85
TP25DG24S05	24(2:1)	18-36	5	5	84
TP25DG24S12	24(2:1)	18-36	12	2.1	87
TP25DG24S15	24(2:1)	18-36	15	1.67	87
TP25DG24S24	24(2:1)	18-36	24	1.04	86
TP25DG24D05	24(2:1)	18-36	± 5	± 2.5	83
TP25DG24D12	24(2:1)	18-36	± 12	± 1.04	86
TP25DG24D15	24(2:1)	18-36	± 15	± 0.83	86
TP25DG48S03	48(2:1)	36-72	3.3	5	85
TP25DG48S05	48(2:1)	36-72	5	5	84
TP25DG48S12	48(2:1)	36-72	12	2.1	87
TP25DG48S15	48(2:1)	36-72	15	1.67	87
TP25DG48S24	48(2:1)	36-72	24	1.04	86
TP25DG48D05	48(2:1)	36-72	± 5	± 2.5	83
TP25DG48D12	48(2:1)	36-72	± 12	± 1.04	86
TP25DG48D15	48(2:1)	36-72	± 15	± 0.83	86
TP25DG24S05W	24(4:1)	9-36	5	5	81
TP25DG24S12W	24(4:1)	9-36	12	2.1	85
TP25DG24S15W	24(4:1)	9-36	15	1.67	85
TP25DG24S24W	24(4:1)	9-36	24	1.04	85
TP25DG24D05W	24(4:1)	9-36	± 5	± 2.5	81
TP25DG24D12W	24(4:1)	9-36	± 12	± 1.04	84
TP25DG24D15W	24(4:1)	9-36	± 15	± 0.83	84
TP25DG48S05W	48(4:1)	18-72	5	5	81
TP25DG48S12W	48(4:1)	18-72	12	2.1	85
TP25DG48S15W	48(4:1)	18-72	15	1.67	85
TP25DG48S24W	48(4:1)	18-72	24	1.04	85
TP25DG48D05W	48(4:1)	18-72	± 5	± 2.5	81
TP25DG48D12W	48(4:1)	18-72	± 12	± 1.04	84
TP25DG48D15W	48(4:1)	18-72	± 15	± 0.83	84

All specifications typical at TA=25°C, nominal input voltage and rated output current unless otherwise specified.

GENERAL CHARACTERISTICS					
parameter	Test conditions	Min	Typ	Max	Units
Isolation voltage	Input to output		500	1500	VDC
Insulation resistance	Input to output	100M			Ohm
Seismic	10~55Hz		5		G
MTBF	MIL-HDBK-217F2		5*10 ⁵		hrs
Over-current protection mode	All input range	Burp, Automatic recovery			
Cooling	Free air convection				
Case material	Metal case				

INPUT CHARACTERISTICS					
parameter	Test conditions	Min	Typ	Max	Units
Startup voltage	The12V input module(9V-18V)	9.2	9.5	9.8	VDC
Startup voltage	The24V input module(18V-36V)			18	VDC
Startup voltage	The48V input module(36V-72V)			36	VDC
Input under voltage protection	The12V input module(9V-18V)	8.8	9	9.3	VDC
Input under voltage protection	The24V input module(18V-36V)			18	VDC
Input under voltage protection	The48V input module(36V-72V)			8.5	VDC
Startup time	Output rise time from 5% to 100%			17	VDC
Remote control CTL	Remote CTL-Vin			35	VDC
Remote control CTL	Remote CTL NC(The control level 12V-40V)	20			ms
Startup voltage	The12V input module(9-18v)			Turn off	
Startup voltage	The24V input module(18-36)			Turn on	

OUTPUT CHARACTERISTICS					
parameter	Test conditions	Min	Typ	Max	Units
Voltage accuracy	$I_o=0.1 \dots 1.0 \times I_{onom}$ $V_i=V_i$ rated			±1	%
Line regulation	$V_{imin} \leq V_i \leq V_{imax}$			±0.2	%
Load regulation	$I_o=0.1 \dots 1.0 \times I_{onom}$ $V_{imin} \leq V_i \leq V_{imax}$			±0.5	%
Auxiliary voltage accuracy	Main Load and auxiliary load differ 25%, the auxiliary circuit of the load with at least 25%, the main circuit with full load			±3	%
Ripple and noise	20MHz bandwidth			±1	%
Over-current protection	$V_{imin} \leq V_i \leq V_{imax}$	120			%
Output voltage trim range	$V_{imin} \leq V_i \leq V_{imax}$			10	%
Transient recovery time	25% load changes			±5	%
Transient overshoot time	25% load changes			400	us
Switch frequency	$V_{imin} \leq V_i \leq V_{imax}$		300		KHz

ENVIRONMENT CHARACTERISTICS					
parameter	Test conditions	Min	Typ	Max	Units
Environment temperature	industrial-class	-25		+55	°C
Maximum case temperature	industrial-class			+85	°C
Storage temperature	Industry-class/ Military J1&J11 class	-40		+105	°C
Relative humidity	No condensation	5		90	RH(%)
Temperature coefficient			±0.02		%/°C

- Module in every environment temperature rating, case temperature under shall not exceed the maximum case temperature level.

MECHANICAL DIMENSIONS

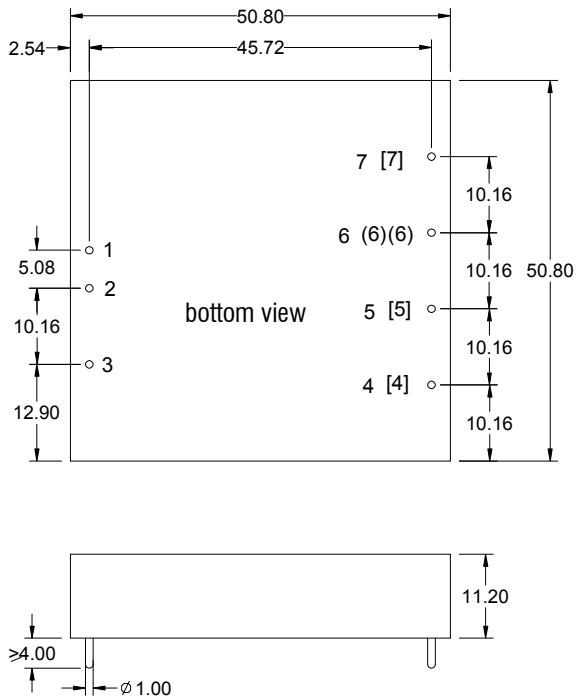

Units: mm
Tolerance: ± 0.2 mm

PIN CONNECTION			
Pin	Single Output	Dual Output	Three Output
1	+Vin	+Vin	+Vin
2	-Vin	-Vin	-Vin
3	CTL	CTL	CTL
4	TRM	TRM	/
[4]	/	/	-Vout3
5	-Vout	-Vout	/
[5]	/	/	COM
6	+Vout	/	/
(6)	/	COM	/
[6]	/	/	+Vout1
7	/	+Vout	/
[7]	/	/	+Vout2

MODEL SELECTION

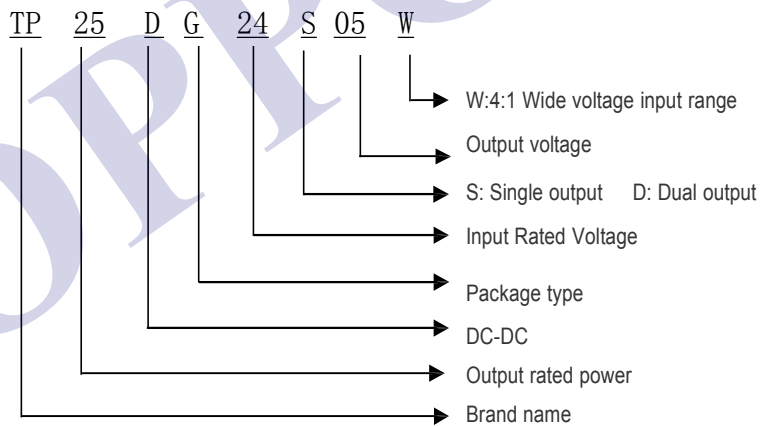

RECOMMEND CIRCUIT

Single Output:

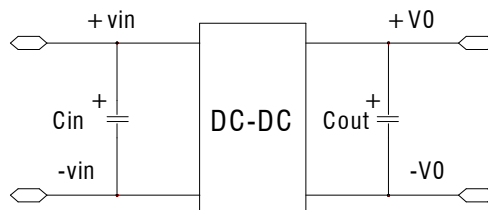

RECOMMEND CIRCUIT

Dual Output :

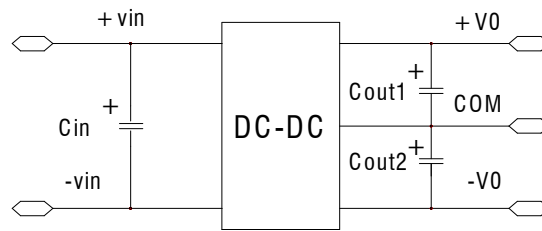

- Add input capacitance C_{in} is helpful to improve the electromagnetic compatibility, recommend C_{in} use 47 uF-100uF of the electrolytic capacitors.
- If the module connect to the digital circuits, please add the C_{out} , C_{out1} , C_{out2} .
- If C_{out} , C_{out1} , C_{out2} value is too high or lower ESR, it will cause the module instable,
- The recommended value of C_{out} , C_{out1} , C_{out2} should be 100 uF/A, the current here means the output current.

Trim application & Trim Resistance

Raise the output Voltage

Down the output voltage

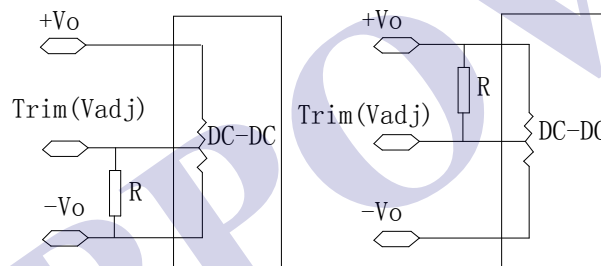

- In dual and triple output modules, this application can just used in the main load(auxiliary load change together with the main load)

USING ATTENTIONS

- Module will cause irreversible damage when in the state of the input reverse polarity.
- Module will cause irreversible damage when in the long-term overload conditions.
- Module will cause irreversible damage when out of the maximum input voltage range.

TEMPERATURE RATED FOR