

ATTENTION
OBSERVE PRECAUTIONS
FOR HANDLING
ELECTROSTATIC
DISCHARGE
SENSITIVE
DEVICES

HL-1008U70GC

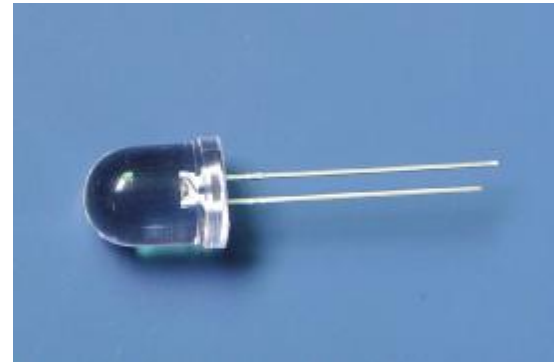

Features

- ϕ 10 LAMP LED
- LOW POWER CONSUMPTION.
- CABINED VIEWING ANGLE.
- IDEAL FOR BACKLIGHT AND INDICATOR.
- PACKAGE: 300PCS / BAG.

Package Dimensions

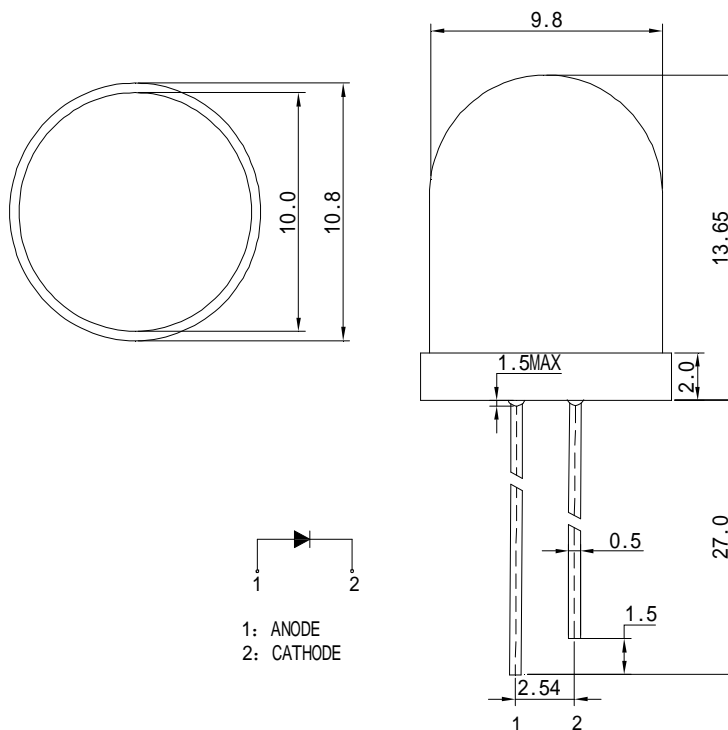

Description

This devices are made with TS InGaN.

| Tolerance Grade | Dimension Tolerance (UNIT:mm) | | | |
|-----------------|-------------------------------|-------------|------|--------|
| | 0.5~3 | 3~6 | 6~30 | 30~120 |
| | ±0.1 | ±0.2 | ±0.3 | ±0.5 |
| Chip | | Lens Color | | |
| Material | Emitting Color | Water Clear | | |
| InGaN | Green | | | |

■ Absolute Maximum Rating

| Item | Symbol | Value | Unit |
|-----------------------------|------------------|--------------------------|------|
| Forward Current | I _F | 20 | mA |
| Peak Forward Current* | I _{FP} | 100 | mA |
| Reverse Voltage | V _R | 5 | V |
| Power Dissipation | P _D | 80 | mW |
| Electrostatic discharge | E _{SD} | 2000 | V |
| Operation Temperature | T _{opr} | -30~+80 | °C |
| Storage Temperature | T _{stg} | -30~+80 | °C |
| Lead Soldering Temperature* | T _{sol} | Max. 260°C for 5sec Max. | |

*I_{FP} Conditions: Pulse Width ≤ 10msec

*T_{sol} Conditions: 3mm from the base of the epoxy bulb

■ Typical Optical/ Electrical Characteristics Ta=25°C

| Item | Symbol | Condition | Rank | Min. | Typ. | Max. | Unit |
|---------------------------|----------------------|----------------------|------|-------|------|-------|------|
| Luminous Intensity | I _v | I _F =20mA | Z3 | 14000 | | 18200 | mcd |
| | | | Z4 | 18200 | | 23660 | mcd |
| | | | Z5 | 23660 | | 30750 | mcd |
| Forward Voltage | V _F | | | 2.8 | 3.2 | 3.6 | V |
| Viewing Angle | 2θ 1/2 | | | -- | 20 | -- | deg |
| Dominant Wavelength | λ _D | | | | 515 | -- | 525 |
| Recommend Forward Current | I _F (rec) | -- | | -- | -- | 20 | mA |
| Reverse Current | I _R | V _r =5V | | -- | -- | 10 | uA |

Notes:

Tolerance : V_F ± 0.1V, λ_D ± 2 nm, I_v(φ V) ± 15%, 2θ 1/2 ± 15%

**■ Reliability Performance
 Test Items And Result**

| Test Classification | Test Item | Test Conditions | Test Duration | Sample Size | AC/RE |
|---------------------|---|--|---------------|-------------|-------|
| Life Test | Room Temperature DC Operating Life Test | Ta=25°C±5°C, I _F =20mA | 1000hrs | 22 pcs | 0/1 |
| Environment Test | Thermal Shock Test | 100°C±5°C 5min ↑ ↓ -40°C±5°C 5min. | 100cycles | 22 pcs | 0/1 |
| | Temperature Cycle Test | 100°C±5°C 30min ↑ ↓5min -40°C±5°C 30min. | 100cycles | 22 pcs | 0/1 |
| | High Temperature & High Humidity Test | 85°C ±5°C/85% RH I _F =5mA | 1000hrs | 22 pcs | 0/1 |
| | High Temperature Storage | Ta=100°C ±5°C | 1000hrs | 22 pcs | 0/1 |
| | Low Temperature Storage | Ta=-40°C ±5°C | 1000hrs | 22 pcs | 0/1 |
| Mechanical Test | Resistance to Soldering Heat | Temp=260°C max T=5sec max | 1times | 22 pcs | 0/1 |
| | Lead Integrity | Load 2.5N(0.25kgf) 0° ~ 90° ~0° | 3times | 22 pcs | 0/1 |

Forward Current vs. Ambient Temperature

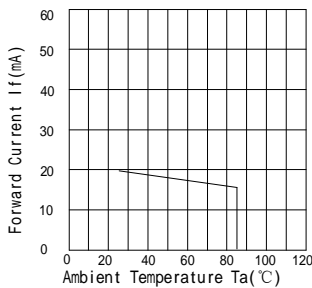

Relative Intensity vs. Ambient Temperature

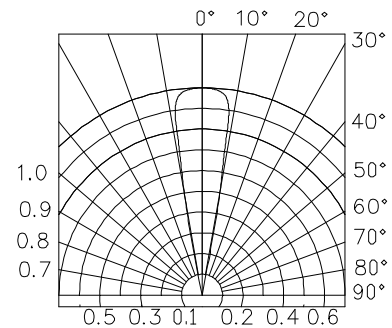
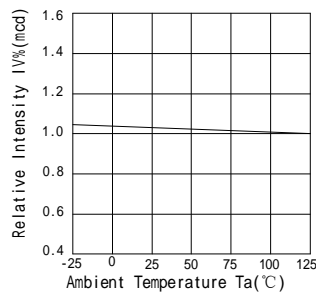

Forward Current vs. Forward Voltage

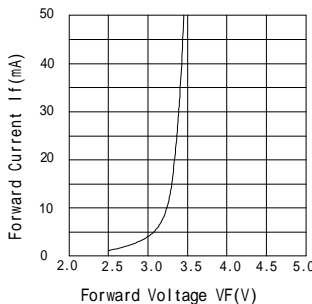

Forward Voltage vs. Ambient Temperature

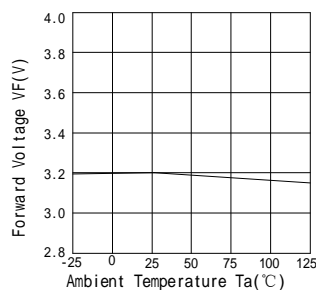

Luminous Spetrum(Ta=25°C) SPECTRAL RADIANCE

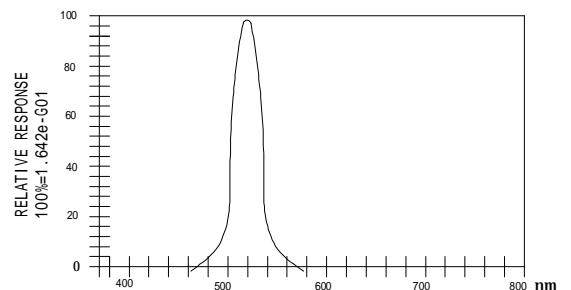

Soldering:

1. Manual Of Soldering

The temperature of the iron tip should not be higher than 300°C and Soldering within 3 seconds per solder-land is to be observed.

2. DIP soldering (Wave Soldering):

Preheating: 120°C~150°C, within 120~180 sec.

Operation heating: 245°C ± 5°C within 5 sec. 260°C (Max)

Gradual Cooling (Avoid quenching).

