

**ATTENTION**  
OBSERVE PRECAUTIONS  
FOR HANDLING  
ELECTROSTATIC  
DISCHARGE  
SENSITIVE  
DEVICES

**Features**

- $\phi$  10 LAMP LED
- LOW POWER CONSUMPTION.
- CABINED VIEWING ANGLE.
- IDEAL FOR BACKLIGHT AND INDICATOR.
- PACKAGE: 1000PCS / BAG.

HL-1008S7VC

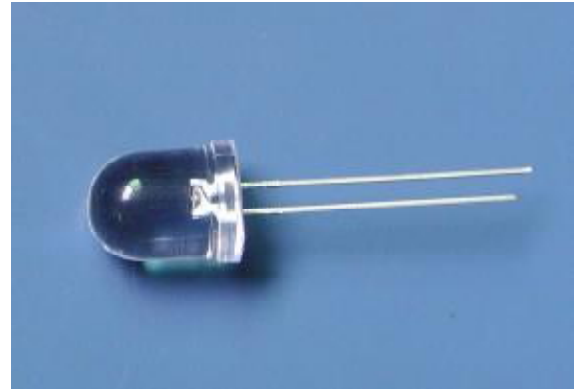

**Package Dimensions**

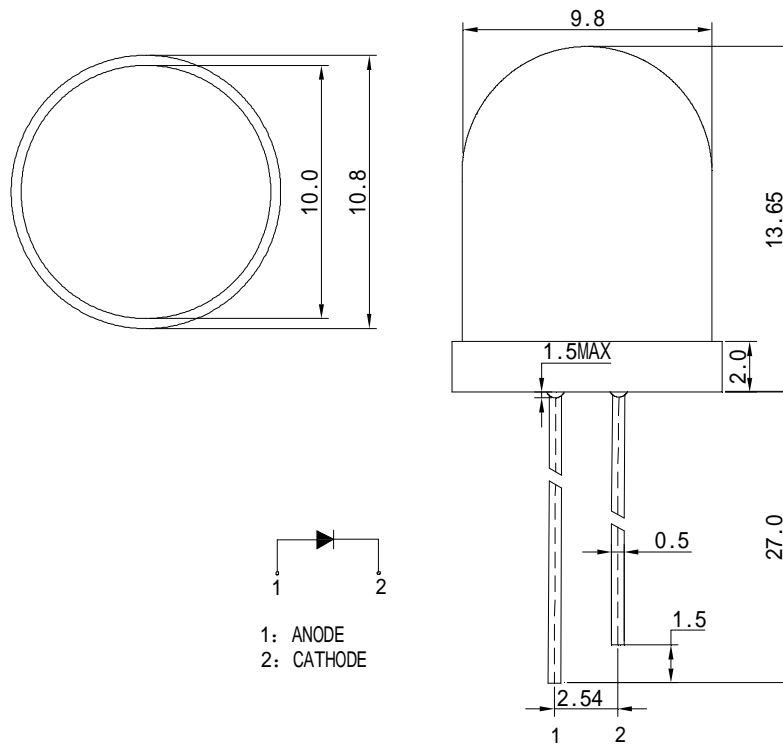

**Description**

This devices are made with TS InGaN.

Tolerance Grade	Dimension Tolerance (UNIT:mm)			
	0.5~3	3~6	6~30	30~120
	±0.1	±0.2	±0.3	±0.5
Chip		Lens Color		
Material	Emitting Color	Water Clear		
InGaN	Violet			

**■ Absolute Maximum Rating**

Item	Symbol	Value	Unit
Forward Current	I <sub>F</sub>	20	mA
Peak Forward Current*	I <sub>FP</sub>	100	mA
Reverse Voltage	V <sub>R</sub>	5	V
Power Dissipation	P <sub>D</sub>	80	mW
Electrostatic discharge	E <sub>SD</sub>	600	V
Operation Temperature	T <sub>opr</sub>	-30~+80	°C
Storage Temperature	T <sub>stg</sub>	-30~+80	°C
Lead Soldering Temperature*	T <sub>sol</sub>	Max. 260°C for 5sec Max.	

\*I<sub>FP</sub> Conditions: Pulse Width ≤ 10msec

\*T<sub>sol</sub> Conditions: 3mm from the base of the epoxy bulb

**■ Typical Optical/ Electrical Characteristics Ta=25°C**

Item	Symbol	Condition	Rank	Min.	Typ.	Max.	Unit
Luminous Intensity	I <sub>v</sub>	I <sub>F</sub> =20mA	H	55		70	mcd
			I	70		90	mcd
			J	90		125	mcd
Forward Voltage	V <sub>F</sub>			2.8	3.2	3.6	V
Viewing Angle	2θ 1/2			--	20	--	deg
Dominant Wavelength	λ <sub>D</sub>				430	--	440
Recommend Forward Current	I <sub>F</sub> (rec)	--		--	--	20	mA
Reverse Current	I <sub>R</sub>	V <sub>r</sub> =5V		--	--	10	uA

Notes:

Tolerance : V<sub>F</sub> ± 0.1V, λ<sub>D</sub> ± 2 nm, I<sub>v</sub>(φ V) ± 15%, 2θ 1/2 ± 15%

**Reliability Performance  
 Test Items And Result**

Test Classification	Test Item	Test Conditions	Test Duration	Sample Size	AC/RE
Life Test	Room Temperature DC Operating Life Test	Ta=25°C±5°C, I <sub>F</sub> =20mA	1000hrs	22 pcs	0/1
Environment Test	Thermal Shock Test	100°C±5°C 5min ↑ ↓ -40°C±5°C 5min.	100cycles	22 pcs	0/1
	Temperature Cycle Test	100°C±5°C 30min ↑ ↓5min -40°C±5°C 30min.	100cycles	22 pcs	0/1
	High Temperature & High Humidity Test	85°C ± 5°C/85% RH I <sub>F</sub> =5mA	1000hrs	22 pcs	0/1
	High Temperature Storage	Ta=100°C ± 5°C	1000hrs	22 pcs	0/1
	Low Temperature Storage	Ta=-40°C ± 5°C	1000hrs	22 pcs	0/1
Mechanical Test	Resistance to Soldering Heat	Temp=260°C max T=5sec max	1times	22 pcs	0/1
	Lead Integrity	Load 2.5N(0.25kgf) 0° ~ 90° ~0°	3times	22 pcs	0/1

Forward Current vs. Ambient Temperature

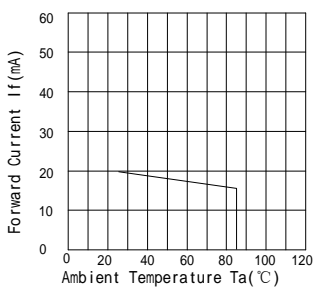

Relative Intensity vs. Ambient Temperature

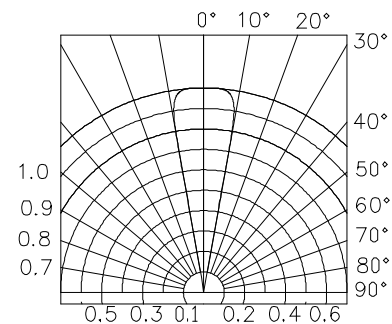
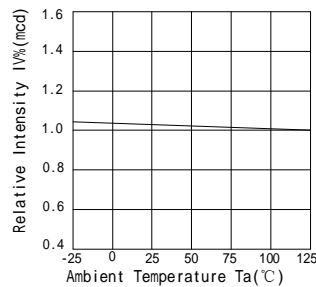

Forward Current vs. Forward Voltage

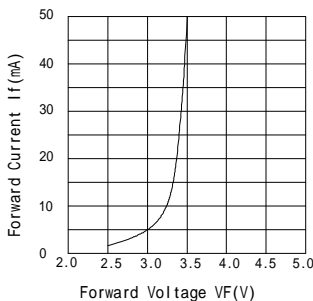

Forward Voltage vs. Ambient Temperature

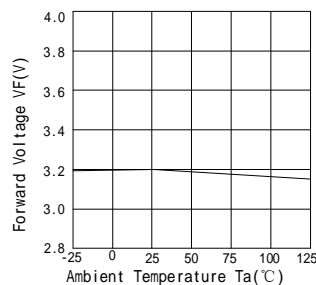

Luminous Spectrum (Ta=25°C) SPECTRAL RADIANCE

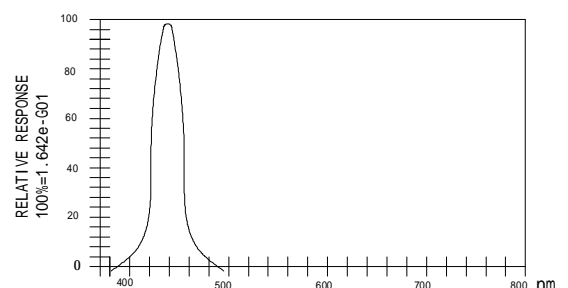

**Soldering:**

## 1. Manual Of Soldering

The temperature of the iron tip should not be higher than 300°C and Soldering within 3 seconds per solder-land is to be observed.

## 2. DIP soldering (Wave Soldering):

Preheating: 120°C~150°C, within 120~180 sec.

Operation heating: 245°C ± 5°C within 5 sec. 260°C (Max)

Gradual Cooling (Avoid quenching).

