



RoHS

# Specification

## 规格书

Customer Name : \_\_\_\_\_

客户名称 :

Customer P/N : \_\_\_\_\_

客户品号 :

Factory P/N : HL-AA-2810H238W-D

公司品号 :

Sending Date : \_\_\_\_\_

送样日期 :

| Client approval<br>客户审核                  |             |  | Hongli approval<br>鸿利光电审核 |  |                    |
|--|-------------|--|---------------------------|--|--------------------|
| Approval<br>核准                           | Audit<br>确认 | Confirmation<br>制作                           | Approval<br>核准            | Audit<br>确认  | Confirmation<br>制作 |
|  |             |  | 殷小平                       |  | 谭娅                 |
| <input type="checkbox"/> Qualified<br>接受 |             | <input type="checkbox"/> Disqualified<br>不接受 |                           | DATE:<br>日期:   |                    |

Adr : Airport High-tech Industry Base Jinggu South Road(XianKe 1st Road Intersection),  
Huadu District, Guangzhou, China

地址: 中国广州市花都区机场高科技产业基地金谷南路与先科一路交汇

Tel/电话 : 020-86733333

Fax/传真 : 020-86733883 86733938 86733265

Web/网址 : www.honglitronic.com

注: 1. 此规格书以中英文方式书写, 若有冲突以中文版本为准文本.

2. 此规格书的最终解释权归广州鸿利光电股份有限公司

3. 此规格书的有效期限为两年, 自盖章或签字之日起计算, 期满时双方可以续签协议, 但应采用书面形式



## HL-AA-2810H238W-D

### Features( 特征)

- Side view LED(侧发光LED)
- Extremely wide viewing angle. ( 宽的发光角度)
- Suitable for all SMT assembly and solder process. ( 适用于所有的SMT组装和焊接工艺)
- Available on tape and reel. ( 适用于载带及卷轴)
- Moisture sensitivity level: Level 4. ( 防潮等级 Level 4)
- Package:3000pcs/reel..(包装每卷3000PCS)
- RoHS compliant. (RoHS 认证)

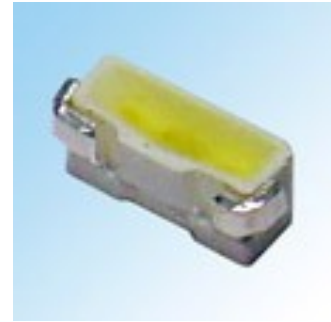

### Description ( 描述)

The White LED which was fabricated using a blue chip and the phosphor  
白光LED由蓝光芯片与荧光粉激发而成



**ATTENTION**  
OBSERVE PRECAUTIONS  
FOR HANDLING  
ELECTROSTATIC  
DISCHARGE  
SENSITIVE  
DEVICES

注意：操作时应注意静电敏感  
释放设备装置

### Applications ( 应用)

- Optical indicator ( 光学指示)
- Indoor display ( 室内显示)
- Automotive lighting ( 汽车照明)
- Backlight for LCD, switch and Symbol, display  
(LCD背光、转换器，开关和标志，显示器等)
- Tubular light application ( 用于日光灯管)
- General use ( 一般应用)

### Package Dimensions ( 封装尺寸)

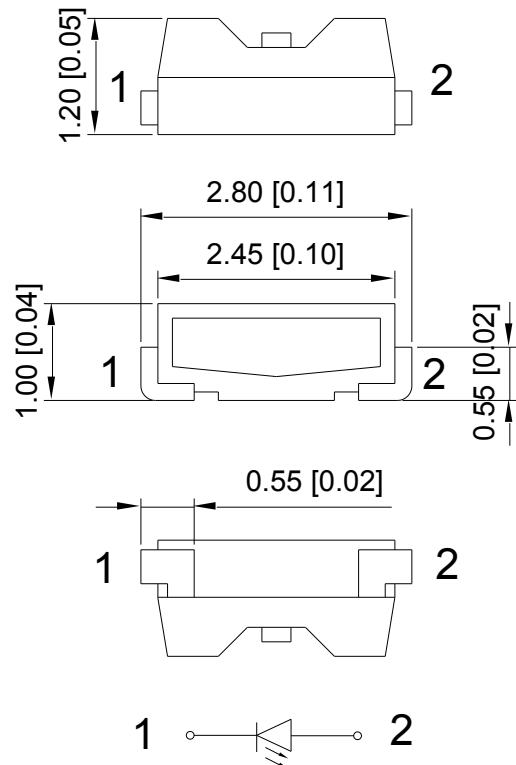

### Recommended Soldering Pattern ( 建议焊盘尺寸图)

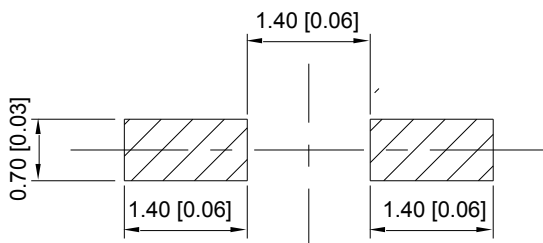

#### Notes: ( 备注)

1. All dimension units are millimeters. ( 所有标注尺寸单位为毫米)
2. All dimension tolerance is  $\pm 0.15\text{mm}$  unless otherwise noted. ( 除特别标注外，所有尺寸允许公差  $\pm 0.15\text{mm}$  )



## HL-AA-2810H238W-D

### Selection Guide (选择指南)

| Part No. 型号       | Dice             | Lens Type<br>胶体类型 | Luminous intensity(mcd)<br>光强@ 20mA |      | Luminous flux(lm)<br>光通量@ 20mA |     | Viewing Angle<br>视角 |
|-------------------|------------------|-------------------|-------------------------------------|------|--------------------------------|-----|---------------------|
|                   |                  |                   | Min.                                | Typ. | Min                            | Typ | 2θ1/2               |
| HL-AA-2810H238W-D | WHITE<br>(InGaN) | Yellow Diffused   | 1100                                | 1200 | 3.0                            | 3.5 | 90°                 |

Note:(备注)

1. θ1/2 is the angle from optical centerline where the luminous intensity is 1/2 the optical centerline value.  
θ1/2 是半值角, 指光强是光学中心线光强的1/2处到光学中心线的角度
2. the above luminous intensity measurement allowance tolerance ±10%.  
上述发光强度的测试允许公差为±10%

### Electrical / Optical Characteristics at Ta=25°C 电性与光学特性

| Parameter (参数)                 | Symbol (符号)    | Min. (最小) | Typ. (平均) | Max. (最大) | Units (单位) | Test Conditions<br>测试条件 |
|--------------------------------|----------------|-----------|-----------|-----------|------------|-------------------------|
| Forward Voltage<br>正向电压        | V <sub>F</sub> | 2.8       | --        | 3.4       | V          | I <sub>F</sub> =20mA    |
| Reverse Current<br>反向电流        | I <sub>R</sub> | --        | --        | 10        | uA         | V <sub>R</sub> = 5V     |
| Color Coordinates<br>色度坐标      | X              | --        | 0.27      | --        | --         | I <sub>F</sub> =20mA    |
|                                | Y              | --        | 0.275     | --        | --         | I <sub>F</sub> =20mA    |
| Color Temperature<br>色温        | T <sub>c</sub> | --        | 12000     | --        | K          | I <sub>F</sub> =20mA    |
| Color Rendering Index<br>显色性指数 | CRI            | 65        | --        | --        | Ra         | I <sub>F</sub> =20mA    |

### Absolute Maximum Ratings at Ta=25°C 绝对最大额定值

| Parameter (参数)                     | Symbol (符号)      | Rating (值) | Units (单位) |
|------------------------------------|------------------|------------|------------|
| Power Dissipation (功耗)             | P <sub>d</sub>   | 105        | mW         |
| Forward Current (正向电流)             | I <sub>F</sub>   | 30         | mA         |
| Peak Forward Current [1] (峰值正向电流)  | I <sub>FP</sub>  | 100        | mA         |
| Reverse Voltage (反向电压)             | V <sub>R</sub>   | 5          | V          |
| Electrostatic Discharge (HBM) (静电) | ESD              | 1000       | V          |
| Operating Temperature (操作温度)       | T <sub>opr</sub> | -40 ~ +85  | °C         |
| Storage Temperature (保存温度)         | T <sub>stg</sub> | -40 ~ +100 | °C         |

Note: (备注)

1. 1/10 Duty cycle, 0.1ms pulse width. (脉宽0.1ms, 周期1/10)
2. The above forward voltage measurement allowance tolerance is ±0.1V. (以上所示电压测量误差±0.1V)
3. The above color coordinates measurement allowance tolerance is ±0.003. (以上所示坐标测量误差±0.003)



## HL-AA-2810H238W-D

### Typical optical characteristics curves 典型光学特性曲线

Ambient Temperature vs. Forward Current

环境温度与正向电流特性曲线

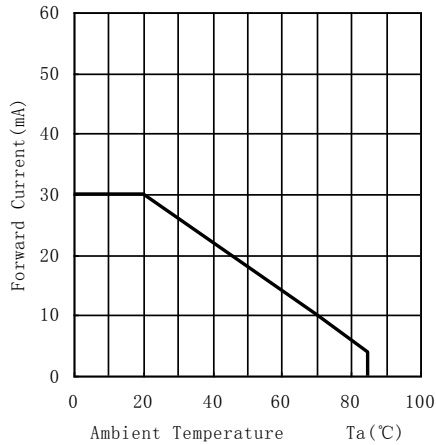

Forward Current VS. Relative Intensity

正向电流与相对光强特性曲线

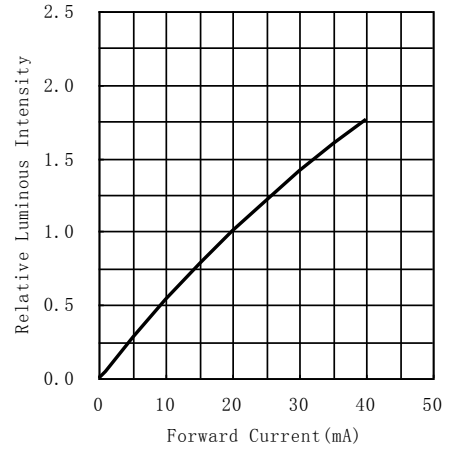

Forward Voltage VS. Forward Current

正向电压与正向电流特性曲线

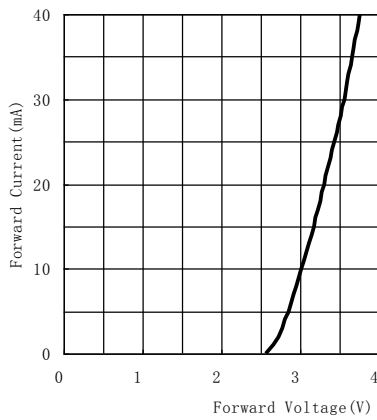

Ambient Temperature VS. Relative Intensity

环境温度与相对光强特性曲线

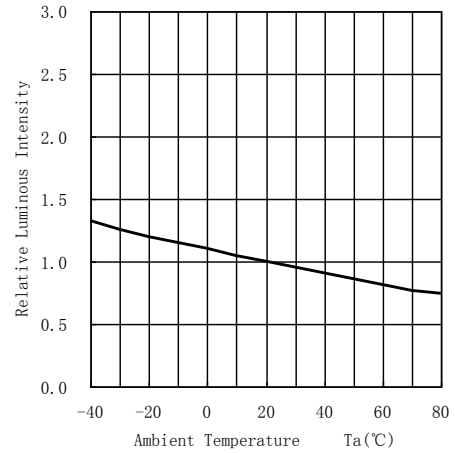

Relative spectral emission

相对光谱分布特性曲线

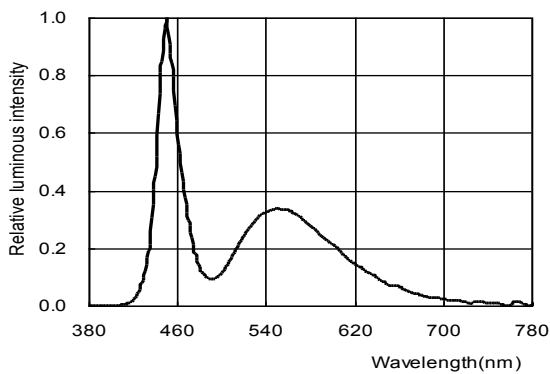

Radiation diagram

辐射图特性曲线

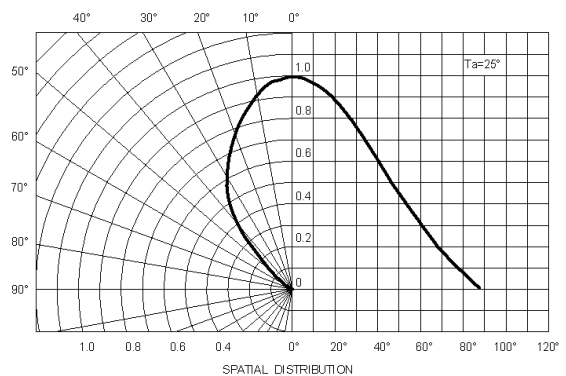



### HL-AA-2810H238W-D

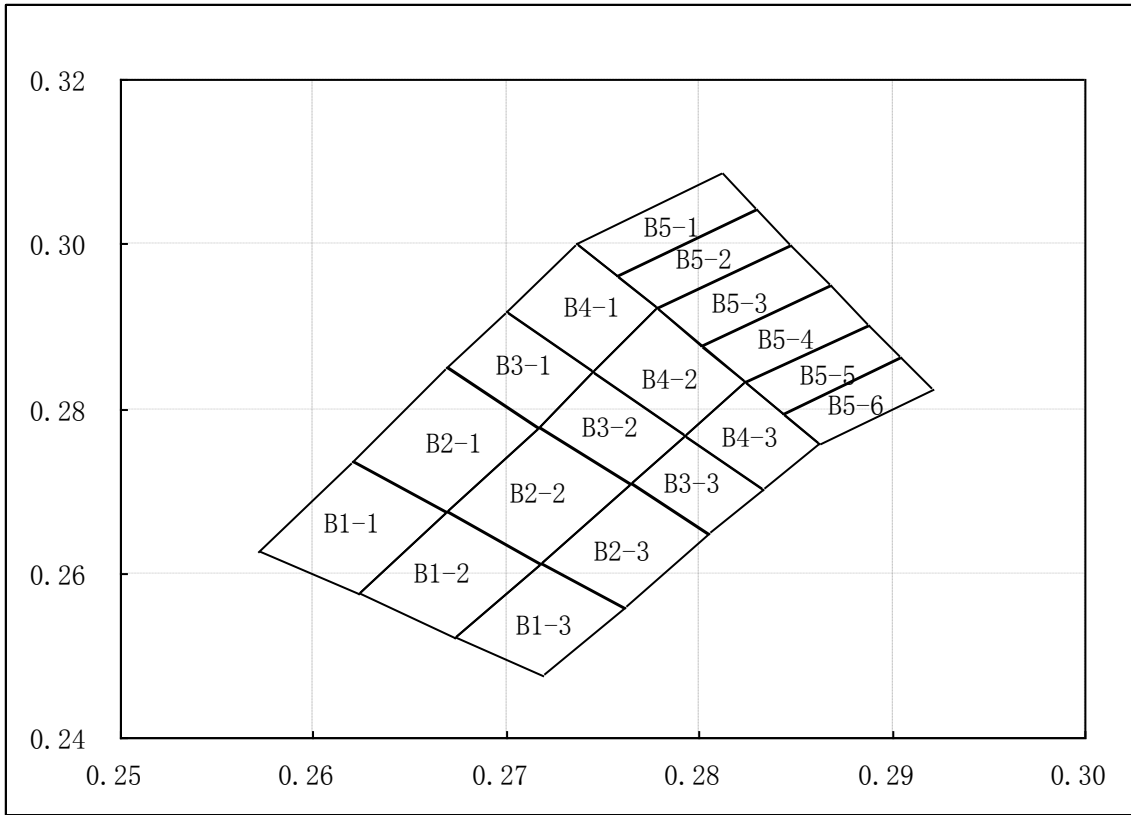

|                   |        |        |        |                   |   |        |        |                   |        |   |        |        |        |        |
|-------------------|--------|--------|--------|-------------------|---|--------|--------|-------------------|--------|---|--------|--------|--------|--------|
| B1-1 14000-16000K |        |        |        | B1-2 14000-16000K |   |        |        | B1-3 14000-16000K |        |   |        |        |        |        |
| x                 | 0.2572 | 0.2620 | 0.2669 | 0.2623            | x | 0.2623 | 0.2669 | 0.2718            | 0.2673 | x | 0.2673 | 0.2718 | 0.2761 | 0.2719 |
| y                 | 0.2626 | 0.2735 | 0.2674 | 0.2574            | y | 0.2574 | 0.2674 | 0.2612            | 0.2522 | y | 0.2522 | 0.2612 | 0.2558 | 0.2475 |
| B2-1 12000-14000K |        |        |        | B2-2 12000-14000K |   |        |        | B2-3 12000-14000K |        |   |        |        |        |        |
| x                 | 0.2620 | 0.2669 | 0.2717 | 0.2669            | x | 0.2669 | 0.2717 | 0.2765            | 0.2718 | x | 0.2718 | 0.2765 | 0.2805 | 0.2761 |
| y                 | 0.2735 | 0.2849 | 0.2778 | 0.2674            | y | 0.2674 | 0.2778 | 0.2708            | 0.2612 | y | 0.2612 | 0.2708 | 0.2649 | 0.2558 |
| B3-1 11000-12000K |        |        |        | B3-2 11000-12000K |   |        |        | B3-3 11000-12000K |        |   |        |        |        |        |
| x                 | 0.2669 | 0.2700 | 0.2745 | 0.2717            | x | 0.2717 | 0.2745 | 0.2793            | 0.2765 | x | 0.2765 | 0.2793 | 0.2833 | 0.2805 |
| y                 | 0.2849 | 0.2918 | 0.2844 | 0.2778            | y | 0.2778 | 0.2844 | 0.2767            | 0.2708 | y | 0.2708 | 0.2767 | 0.2702 | 0.2649 |
| B4-1 10000-11000K |        |        |        | B4-2 10000-11000K |   |        |        | B4-3 10000-11000K |        |   |        |        |        |        |
| x                 | 0.2700 | 0.2737 | 0.2778 | 0.2745            | x | 0.2745 | 0.2778 | 0.2824            | 0.2793 | x | 0.2793 | 0.2824 | 0.2862 | 0.2833 |
| y                 | 0.2918 | 0.3001 | 0.2922 | 0.2844            | y | 0.2844 | 0.2922 | 0.2832            | 0.2767 | y | 0.2767 | 0.2832 | 0.2758 | 0.2702 |
| B5-1 9000-10000K  |        |        |        | B5-2 9000-10000K  |   |        |        | B5-3 9000-10000K  |        |   |        |        |        |        |
| x                 | 0.2737 | 0.2812 | 0.2830 | 0.2758            | x | 0.2758 | 0.2830 | 0.2848            | 0.2778 | x | 0.2778 | 0.2848 | 0.2868 | 0.2801 |
| y                 | 0.3001 | 0.3085 | 0.3042 | 0.2962            | y | 0.2962 | 0.3042 | 0.2999            | 0.2922 | y | 0.2922 | 0.2999 | 0.2951 | 0.2877 |
| B5-4 9000-10000K  |        |        |        | B5-5 9000-10000K  |   |        |        | B5-6 9000-10000K  |        |   |        |        |        |        |
| x                 | 0.2801 | 0.2868 | 0.2888 | 0.2824            | x | 0.2824 | 0.2888 | 0.2905            | 0.2843 | x | 0.2843 | 0.2905 | 0.2921 | 0.2862 |
| y                 | 0.2877 | 0.2951 | 0.2902 | 0.2832            | y | 0.2832 | 0.2902 | 0.2863            | 0.2795 | y | 0.2795 | 0.2863 | 0.2823 | 0.2758 |



## HL-AA-2810H238W-D

### Reliability Test Items And Conditions 信赖性测试项目及条件

| Test Items<br>项目                                      | Ref.Standard<br>参考标准 | Test Condition<br>测试条件                            | Time<br>时间 | Quantity<br>数量 | Ac/Re<br>接收/拒收 |
|---|----------------------|---|------------|----------------|----------------|
| Reflow<br>回流焊   | JESD22-B106          | Temp:260°C max<br>T=10 sec                        | 3 times.   | 22Pcs.         | 0/1            |
| Temperature Cycle<br>温度循环                             | JESD22-A104          | 100°C±5°C 30 min.<br>↑↓5 min<br>-40°C±5°C 30 min. | 100 Cycles | 22Pcs.         | 0/1            |
| High Temperature Storage<br>高温保存                      | JESD22-A103          | Temp:100°C±5°C                                    | 1000Hrs.   | 22Pcs.         | 0/1            |
| Low Temperature Storage<br>低温保存                       | JESD22-A119          | Temp:-40°C±5°C                                    | 1000Hrs.   | 22Pcs.         | 0/1            |
| Life Test<br>常温通电                                     | JESD22-A108          | Ta=25°C±5°C<br>IF=20mA                            | 1000Hrs.   | 22Pcs.         | 0/1            |
| High Temperature<br>High Humidity Life Test<br>高温高湿通电 | JESD22-A101          | 85°C±5°C/ 85%RH<br>IF=5mA                         | 1000Hrs.   | 22Pcs.         | 0/1            |

### Criteria For Judging Damage 失效判定标准

| Test Items<br>项目        | Symbol<br>符号 | Test Condition<br>测试条件 | Criteria For Judgement<br>判定标准 |             |
|-------------------------|--------------|------------------------|--------------------------------|-------------|
|                         |              |                        | Min. 最小                        | Max. 最大     |
| Forward Voltage<br>正向电压 | VF           | IF=20mA                | --                             | U.S.L*)x1.1 |
| Reverse Current<br>反向电流 | IR           | VR = 5V                | --                             | U.S.L*)x2.0 |
| Luminous Flux<br>光通量    | Im           | IF=20mA                | L.S.L*)x0.7                    | --          |

U.S.L: Upper standard level 规格上限

L.S.L: Lower standard level 规格下限

\*The technical information shown in the data sheets are limited to the typical characteristics and circuit examples of the referenced products. It does not constitute the warranting of industrial property nor the granting of any license.

数据工作表中所示的技术信息仅限于典型特征和电路实例引用的产品。它既不构成工业特性的保证,也不构成任何许可的授权



## HL-AA-2810H238W-D

### SMT Reflow Soldering Instructions SMT回流焊说明

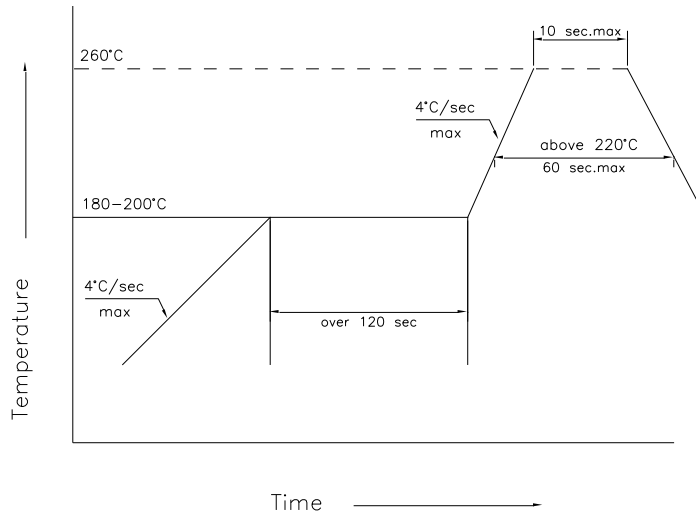

1.Reflow soldering should not be done more than two times. 回流焊不可以做两次以上

2.When soldering , do not put stress on the LEDs during heating

当焊接时，不要在材料受热时用力压胶体表面

### Soldering iron 烙铁焊接

1.When hand soldering, keep the temperature of iron below less 300°C less than 3 seconds

当手工焊接时，烙铁的温度必须小于300°C，时间不可超过3秒

2.The hand solder should be done only one times

手工焊接只可焊接一次

### Repairing 修补

Repair should not be done after the LEDs have been soldered. When repairing is unavoidable, a double-head soldering iron should be used (as below figure). It should be confirmed in advance whether the characteristics of LEDs will or will not be damaged by repairing.

LED回流焊后不应该修复，当修复是不可避免时，必须使用双头烙铁（如下图），但必须先确认此种方式会不会损坏LED本身的特性。

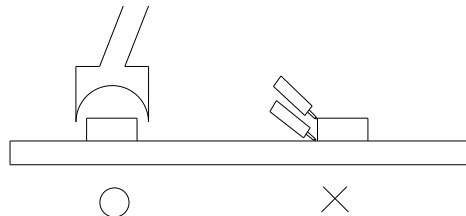

### Cautions 注意事项

The encapsulated material of the LEDs is silicone. Therefore the LEDs have a soft surface on the top of package. The pressure to the top surface will be influence to the reliability of the LEDs. Precautions should be taken to avoid the strong pressure on the encapsulated part. So when use the picking up nozzle, the pressure on the silicone resin should be proper.

LED封装为硅胶，故LED胶体表面较软，用力按压胶体表面会影响LED可靠性，因此应有预防措施避免在封装的零件上的强大压力，当使用吸嘴时，胶体表面的压力应是恰当的。



## HL-AA-2810H238W-D

### Handling Precautions 处理防备措施

Compare to epoxy encapsulant that is hard and brittle, silicone is softer and flexible. Although its characteristic significantly reduces thermal stress, it is more prone to damage by external mechanical force. As a result, Special handling precautions must be observed during assembling using silicone encapsulated LED products, Failure to comply might leads to damage and premature failure of the LED.

相对环氧树脂较脆较硬而言，硅胶封装较柔软且有弹性，虽然它的特性大大减少了热应力，但易受机械外力损坏，因此在手工处理方面须要对硅胶封装材料做预防措施，若未按要求操作，可能会导致LED损坏和光衰

#### 1.Handle the component along the side surface by using forceps or appropriate tools

通过使用适当的工具从材料侧面夹取

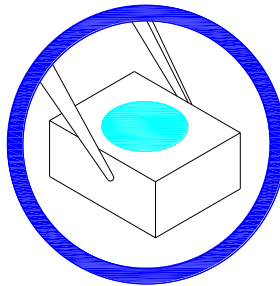

#### 2.Do not directly touch or handle the silicone lens surface. It may damage the internal circuitry

不可直接用手或尖锐金属压胶体表面，它可能会损坏内部电路

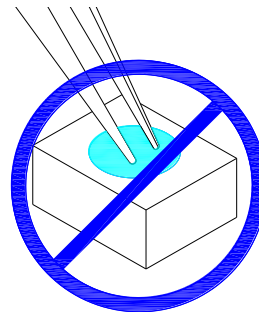
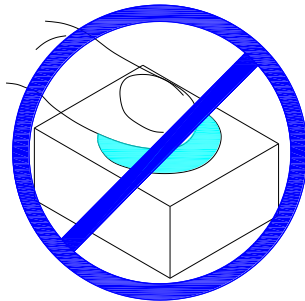

#### 3.Do not available for flexible products( like soft flexible strip) or damage the internal circuitry

不适用于易弯曲产品（如软光条）以防内部电路受损

#### 4.Not suitable to operate in acidic environment, PH<7

不可用在PH<7的酸性场所

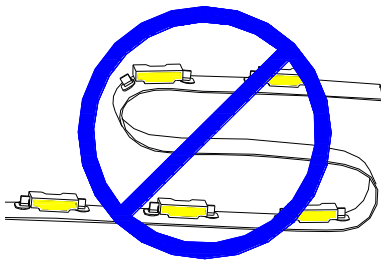

#### 4.LED operating environment and sulfur element composition cannot be over 100PPM in the LED mating usage material

LED工作环境及与LED适配的材料中硫元素及化合物成份不可超过100PPM





# HL-AA-2810H238W-D

## Label 标签

IV: Luminous intensity rank 亮度等级  
 VF: Forward voltage rank 电压等级  
 X/Y: Coordinate rank 色坐标  
 TC: Color temperature 色温

Part No: XXXXXXXXXXXXXXXXXXXXX  
 IV: VF: X/Y:  
 Quantity: TC:  
 Sealing date: XXXXXXXXXXXXXXXXXXXX

## Tape Specifications (Units : mm) 载带规格 (单位: mm)

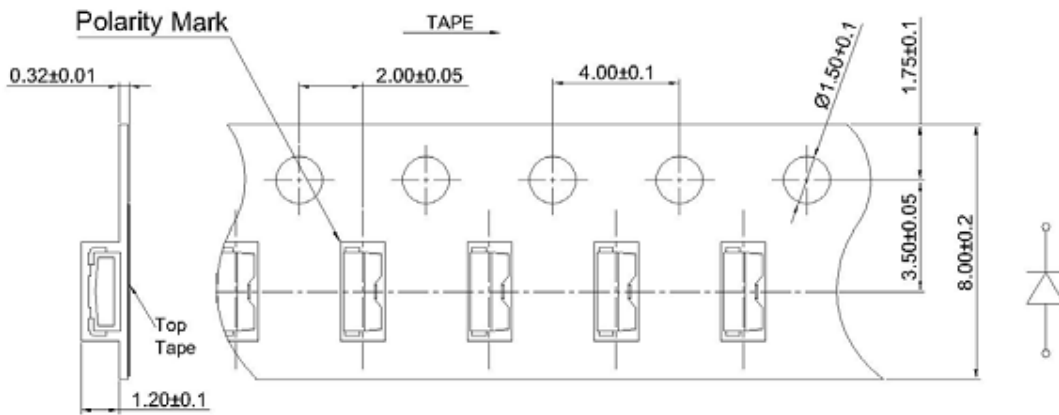

## Reel Dimensions 卷轴尺寸

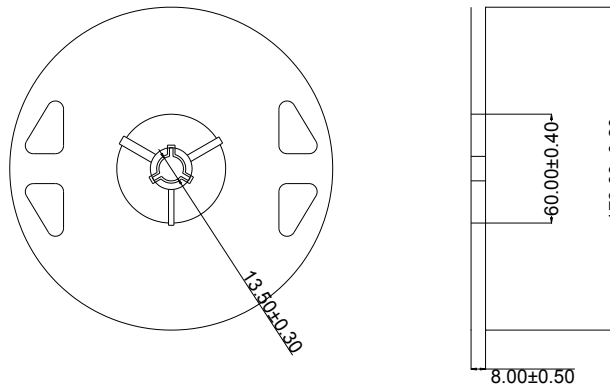

## Moisture Resistant Packaging 防潮带包装

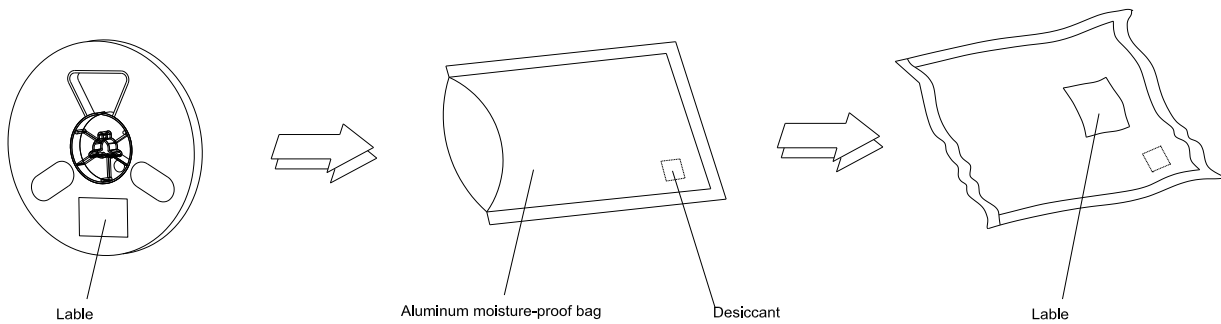

Note: The tolerances unless mentioned is ±0.1mm , Unit: mm 注: 标注公差为 ±0.1mm , 单位: mm