

ATTENTION(注意)
OBSERVE PRECAUTIONS
FOR HANDLING
ELECTROSTATIC
DISCHARGE
SENSITIVE
DEVICES
请勿裸手接触器件

HL-308H256WC-HD

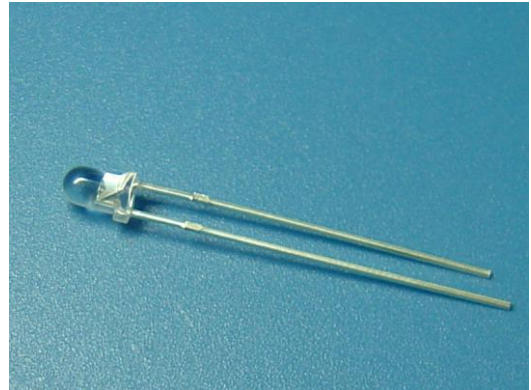

Features (特征)

- φ 3LAMP LED 直插φ 3LED 灯
- LOW POWER CONSUMPTION.低功耗
- WIDE VIEWING ANGLE.小角度
- IDEAL FOR BACKLIGHT AND INDICATOR.
用于背光和指示
- PACKAGE: 1000PCS / BAG.包装:1000PCS/袋

Package Dimensions 封装尺寸

Description 描述

This devices are made with InGaN.
LED 芯片组成元素为 InGaN.

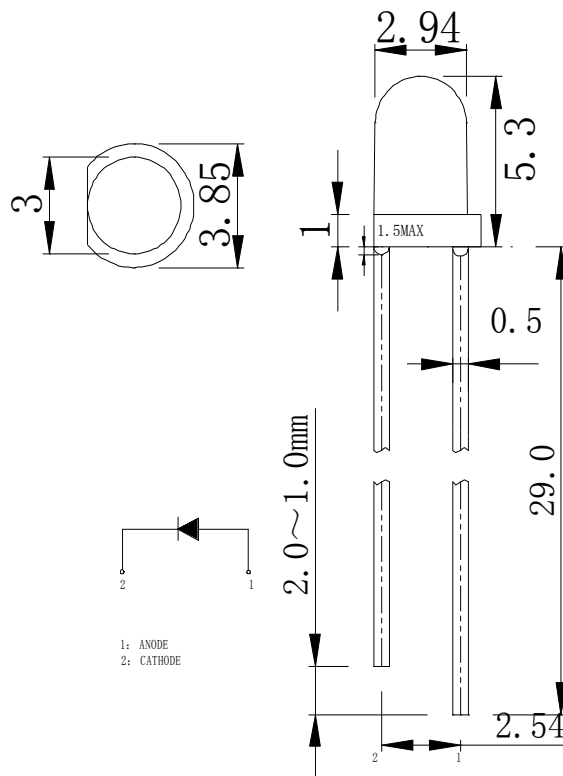

Tolerance Grade 公差等级	Dimension Tolerance (UNIT:mm) 尺寸公差 (单位:mm)			
	0.5~3	3~6	6~30	30~120
	±0.1	±0.2	±0.3	±0.5
	Chip 晶片		Lens Color 透镜颜色	
Material 材料	Emitting Color 发光颜色		Water Clear 无色透明	
InGaN	White 白色			

■ Absolute Maximum Rating 最大数值

Item 项目	Symbol 符号	Value 数值	Unit 单位
Forward Current 正向电压	IF	20	mA
Peak Forward Current* 峰值正向电流	IFP	100	mA
Reverse Voltage 反向电压	VR	5	V
Power Dissipation 功耗	PD	80	mW
Electrostatic discharge 抗静电能力	ESD	1000	V
Operation Temperature 操作温度	Topr	-30~+80	°C
Storage Temperature 储存温度	Tstg	-30~+80	°C
Lead Soldering Temperature* 引脚焊接温度	Tsol	Max. 260°C for 5sec Max.	

IFP Conditions: Pulse Width ≤ 10msec (IFP 正向峰值电流使用条件: 脉冲宽度 ≤ 10 毫秒)

***Tsol Conditions: 3mm from the base of the epoxy bulb**

Tsol 焊接条件: 焊接位置离胶体底部 3 毫米

■ Typical Optical/ Electrical Characteristics Ta=25°C (光电参数 环境温度 25°C)

Item (项目)	Symbol 符号	Condition 条件	Rank 档次	Min. 最小值	Typ. 典型值	Max. 最大值	Unit 单位
Luminous Intensity 光强	I _v	IF=20mA	Z	6370		8280	mcd
			Z1	8280		10750	mcd
			Z2	10750		14000	mcd
Forward Voltage 正向电压	VF			2.8	3.2	3.6	V
Viewing Angle 角度	2θ 1/2			--	25	--	deg
Chromaticity coordinates 色温坐标	X			--	0.31	--	X:±0.015
	Y			--	0.32	--	Y:±0.025
Recommend Forward Current 推荐使用正向电流	IF(rec)	--		--	--	20	mA
Reverse Current 反向电流	IR	Vr=5V		--	--	10	uA

Notes 注意:

Tolerance : VF±0.1V, IV(φ V) ±15%, 2θ 1/2±15%

误差 : 正向电压±0.1V, 光强(光通量)±15%, 角度±15%

The above color coordinates measurement allowance tolerance ±0.003

上述表格中的色坐标的测量误差为±0.003



Forward Current vs.
Ambient Temperature
正向电压与环境温度关系曲线

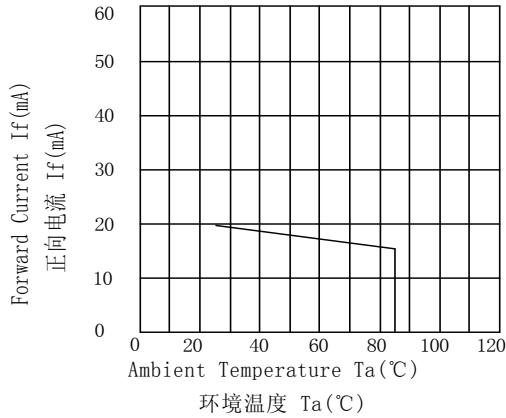

Relative Intensity vs.
Ambient Temperature
相对光强与环境温度关系曲线

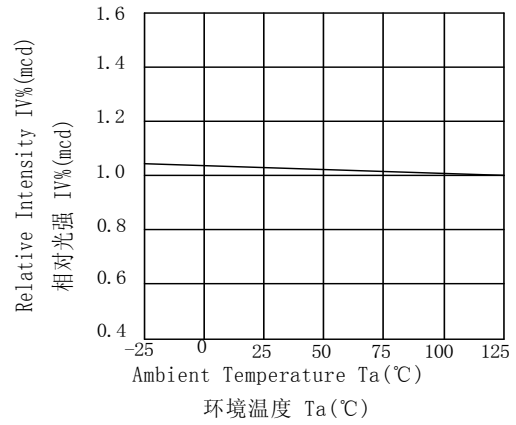

Forward Current vs.
Forward Voltage
正向电压与正向电流关系曲线

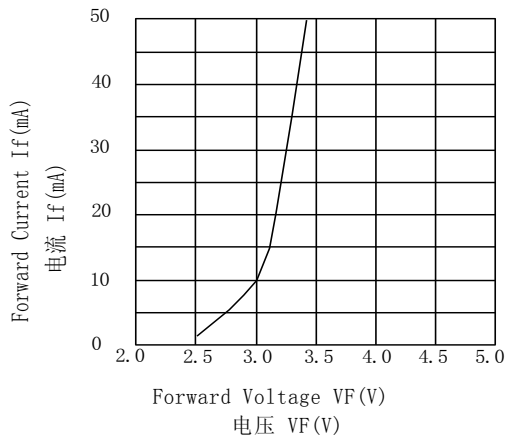

Forward Voltage vs.
Ambient Temperature
正向电压与环境温度关系曲线

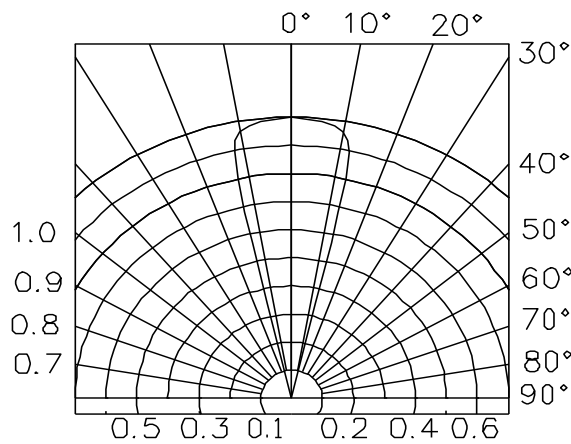
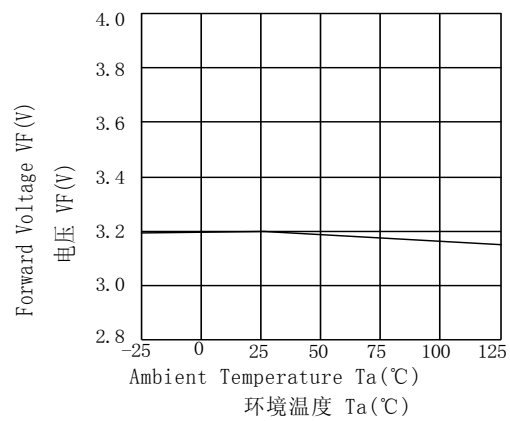

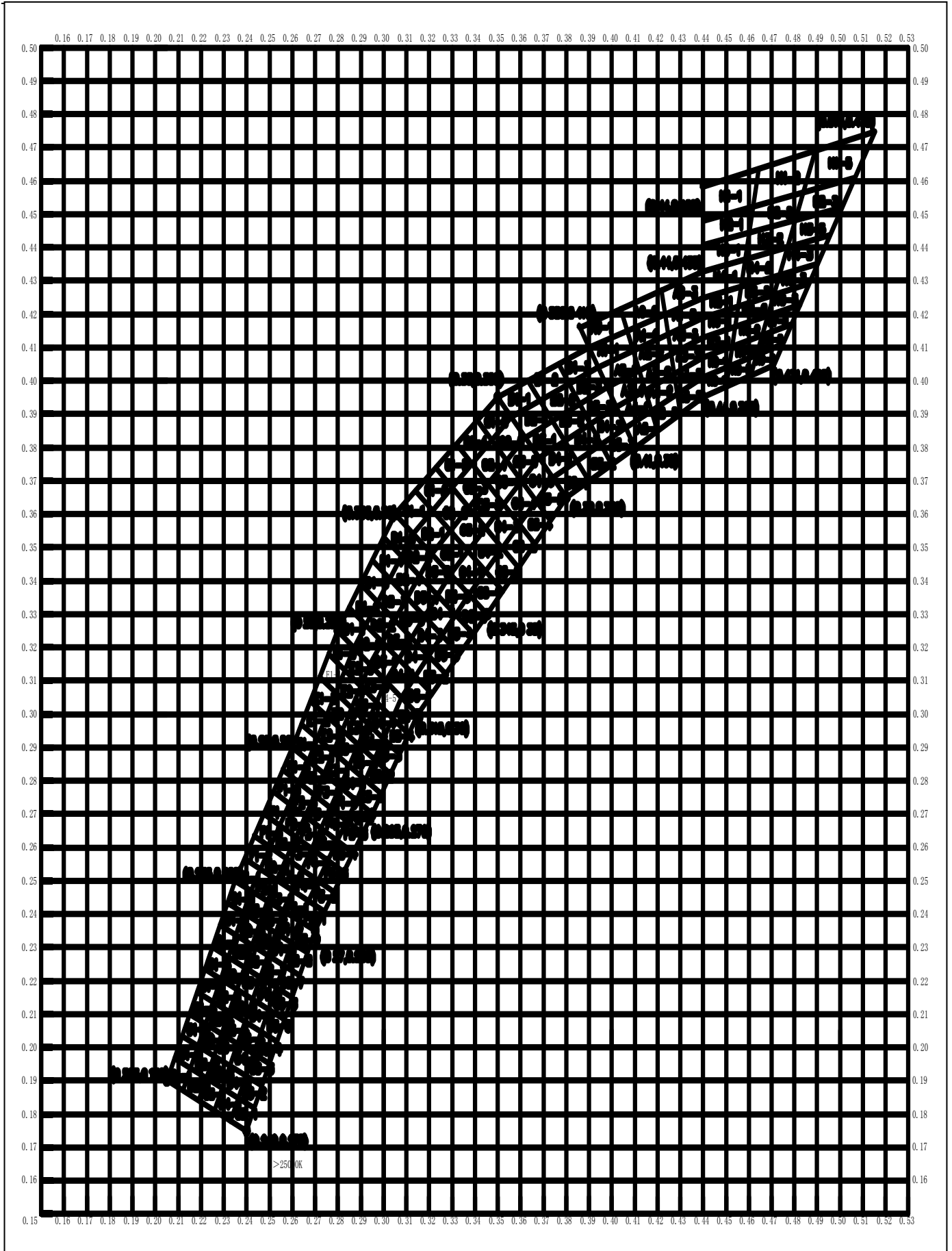

Soldering (焊接) :

1. Manual Of Soldering (手工焊接)

The temperature of the iron tip should not be higher than 300°C and Soldering within 3 seconds per solder-land is to be observed. (烙铁最高温度不高于 300°C, 焊接时间小于 3 秒)

2. DIP soldering (Wave Soldering) (波峰焊接:)

Preheating: 120°C~150°C, within 120~180 sec. (预热温度 120°C~150°C, 小于 120~180 秒)

Operation heating: 245°C ± 5°C within 5 sec. 260°C (Max)

操作温度: 245°C ± 5°C 小于 5 秒, 最高温度不高于 260°C

Gradual Cooling (Avoid quenching).

过完波峰焊后应缓慢冷却。

