



ATTENTION
OBSERVE PRECAUTIONS
FOR HANDLING
ELECTROSTATIC
DISCHARGE
SENSITIVE
DEVICES



Features

- Dimension 2.00mm×1.60mm×0.80mm
- Undomed device architecture
- Low forward voltage
- Low thermal resistance: $R_{th}=6^{\circ}C/W$
- RoHS compliant
- Maximum drive Current: 1000mA
(Duty 1/10@1KHZ)
- Typical luminous flux: 240lm@1000A

Applications

- Portable lightings /(flash lightings, bicycle)

Package Dimensions

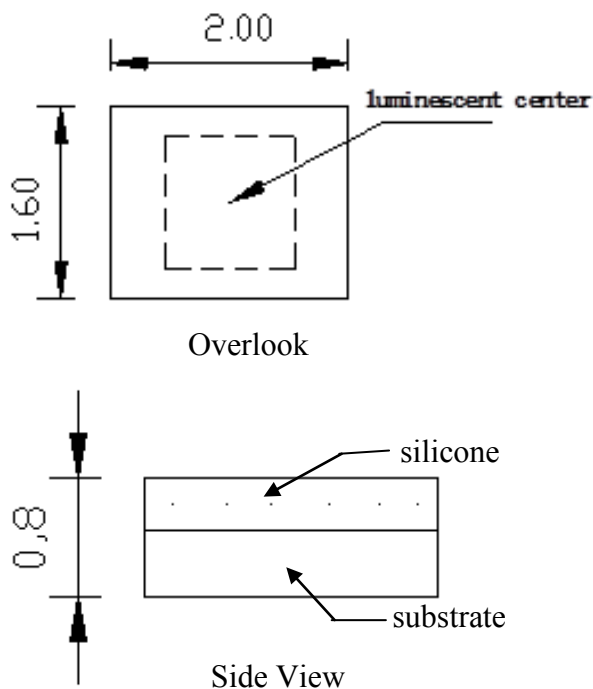

Recommended Soldering Pattern

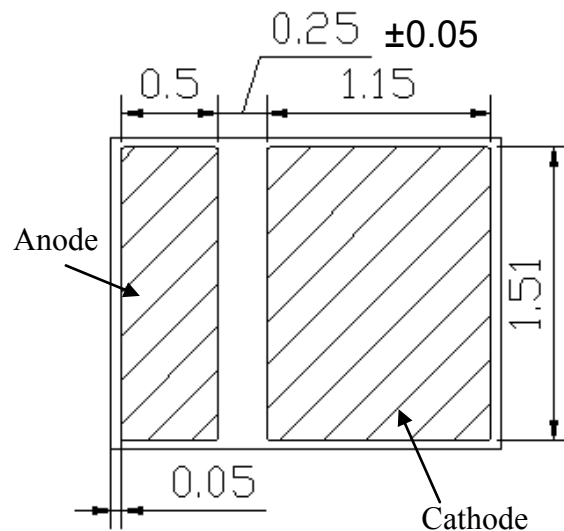

Notes:

1. All dimension units are millimeters.
2. All dimension tolerance is ± 0.1 mm unless otherwise noted.



Radiation Pattern

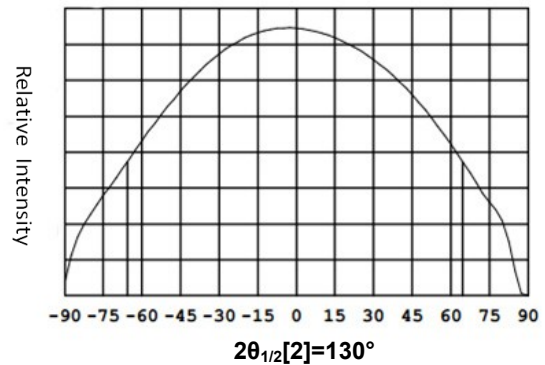
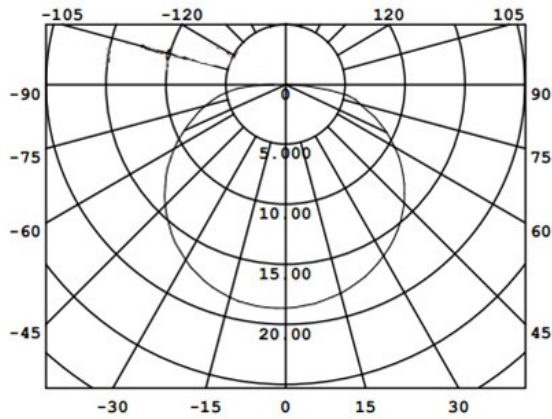

Device Selection Guide

Part No.	Chip		Silicone Color
	Material	Emitting Color	
X-CHIP 2016	InGaN	white	Yellow diffused

Electrical / Optical Characteristics at TA=25°C

Symbol	Parameter	Device	Min.	Typ.	Max.	Units	Test Conditions
Φ_V	Luminous Flux	White	180	200	240	lm	$I_F=700mA$
V_F	Forward Voltage [1]		2.70	3.10	3.50	V	$I_F=700mA$
TC	Color Temperature		5000	—	7000	K	$I_F=700mA$
IR	Reverse Current		—	—	10	μA	$V_R = 5V$
$2\theta_{1/2}$	50% power angle		—	130	—	deg	$I_F=700mA$

Note:

- 1.For each die.
2. $\theta_{1/2}$ is the angle from optical centerline where the luminous flux is 1/2 the optical centerline value.
- 3.The value only for reference.

Absolute Maximum Ratings at TA=25°C

Parameter	Symbol	Rating	Units
Power dissipation	P_d	>3	W
DC Forward Current	I_F	700	mA
Peak Forward Current (Duty 1/10@1KHZ) [1]	I_{FP}	1000	mA
Reverse Voltage[2]	V_R	5	V
Operating Temperature Range	T_{opr}	-40°C To +85°C	
Storage Temperature Range[3]	T_{stg}	-40°C To +100°C	
Thermal Resistance (Junction / Soldering point)	R_{thj-s}	6	°C/W
Junction Temperature	T_j	135	°C

Note:

- 1.1/10 Duty Cycle,0.1ms Pulse Width.
- 2.Forward voltage measurement allowance tolerance is $\pm 0.1V$.
- 3.Bare component without packaging materials.
- 4.Operate at maximum rating conditions continuously will cause possible permanent damage and de-rating parameters.



Typical Optical/Electrical Characteristics Curves ($T_a=25^{\circ}\text{C}$ Unless Otherwise Noted)

Relative Radiant Power-IF

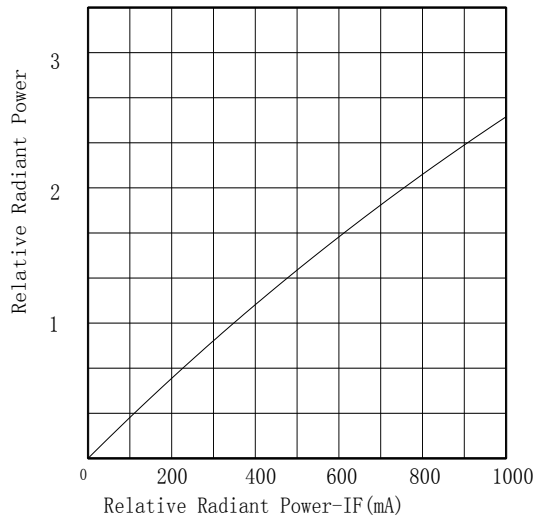

Allowable Forward Current - T_a

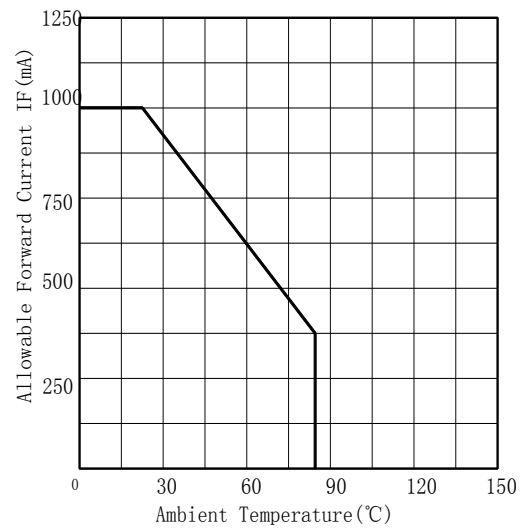

IF - VF

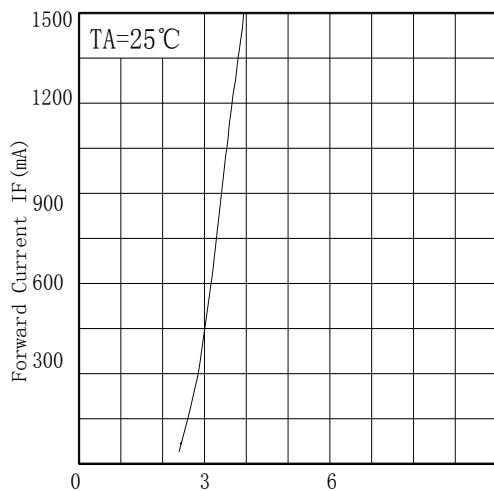

Relative Luminous Intensity - T_a

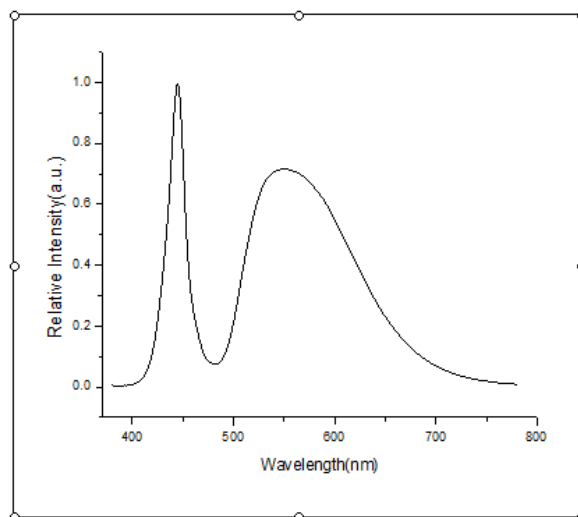
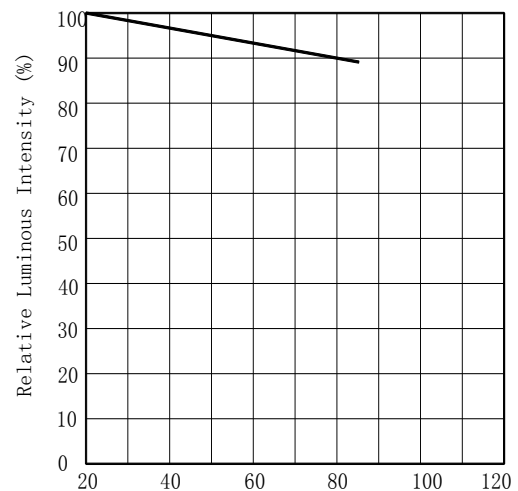



Bin Range of Chromaticity Coordinate Bin (If=700mA)

VF	Range	Φ	Range
VF1	2.7~2.9 V	LM1	180~200 lm
VF2	2.9~3.1 V	LM2	200~220 lm
VF3	3.1~3.3 V	LM3	220~240 lm
VF4	3.3~3.5 V	LM4	>240 lm

White Bin Structure

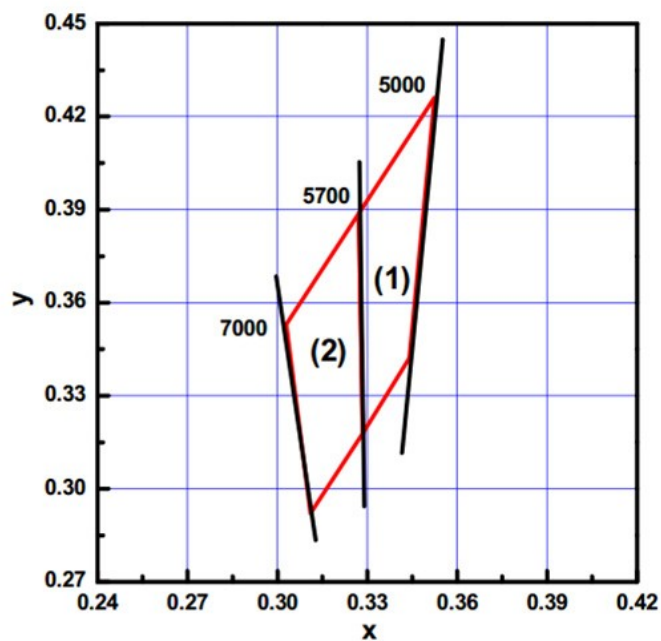

- Notes :
- 1.Color Bin (1) :5057K
 - 2.Color Bin (2) :5770K

White Bin Coordinate

Bin	CIE-X	CIE-Y	CCT Reference Range
5057	0.3272	0.3888	5000K ~5700K
	0.3524	0.4261	
	0.3440	0.3420	
	0.3285	0.3178	
5770	0.3000	0.3486	5700K ~ 7000K
	0.3272	0.3888	
	0.3285	0.3178	
	0.3110	0.2920	

Note:

1. The above forward voltage measurement allowance tolerance is $\pm 0.1V$.
2. The above color coordinates measurement allowance tolerance is ± 0.003 .
3. The above luminous flux allowance tolerance is $\pm 10\%$.



Soldering

Manual Of Soldering

The temperature of the iron tip should not be higher than 300°C and Soldering within 3 seconds per solder-land is to be observed.

Reflow soldering :(All temperatures refer to topside of package, measured on the package body surface.)

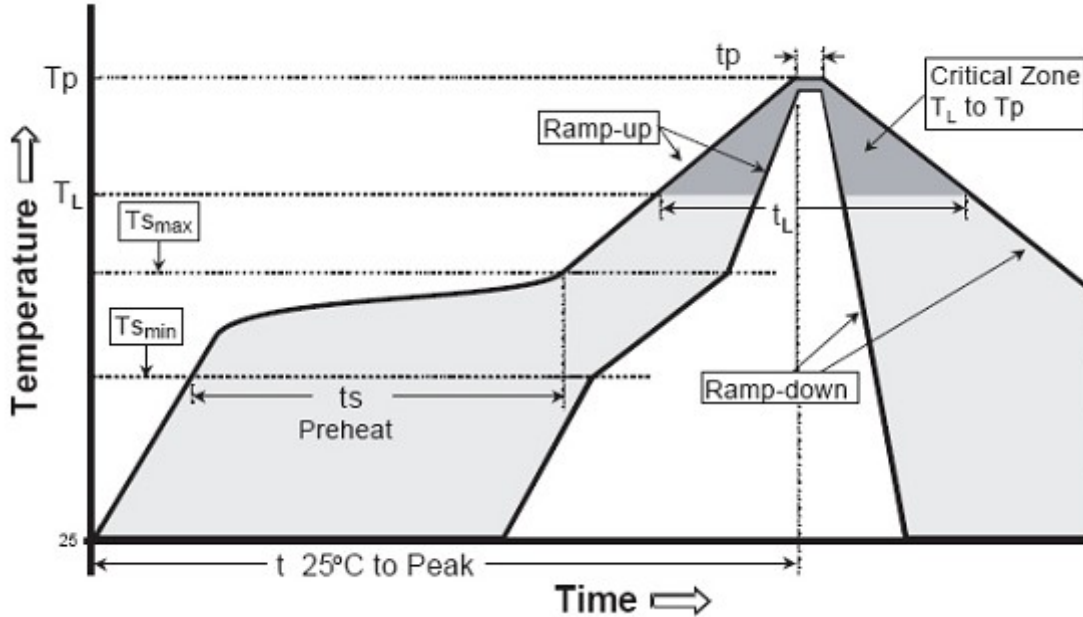

Profile Feature	Lead-Based solder	Lead-Free Solder
Average Ramp-Rate (Ts _{max} to Tp)	3°C/second max	3°C/second max
Preheat: Temperature Min (Ts _{min})	100°C	150°C
Preheat: Temperature Max (Ts _{max})	150°C	200°C
Preheat: Time (ts _{min} to ts _{max})	60-120 seconds	60-180 seconds
Time Maintained Above: Temperature(T _L)	183°C	217°C
Time Maintained Above: Time(t _L)	60-150 seconds	60-150 seconds
Peak/Classification Temperature(T _p)	215°C	240°C
Time Within 5°C of Actual Peak Temperature(tp)	10-15 seconds	20-40 seconds
Ramp-Down Rate	6°C/second max	6°C/second max
Time 25°C to Peak Temperature	6 minutes max	8 minutes max

Caution:

- 1.Reflow soldering should not be done more than two times. The reflow temperature we recommend is 240°C(±5°C),the maximum soldering temperature should be limited under 245°C.
- 2.Repairing should not be done after the LEDs have been soldered. When repairing is unavoidable, suitable tools have to be used.
- 3.When soldering, do not press on the LEDs during heating.
- 4.After soldering, do not warp the circuit board.
- 5.Do not add any stress on the component.



X-CHIP 2016LC-GL

Label 标签

IV : Luminous intensity rank 亮度等级
 VF: Forward voltage rank 电压等级
 X/Y: Coordinate rank 色坐标
 TC: Color temperature 色温



Tape Specifications (Units : mm) 载带规格 (单位 : mm)

参数代号	标准
A0	1.80±0.1
B0	2.25±0.1
K0	1.00±0.1
P0	4.00±0.1
P1	4.00±0.1
P2	2.00±0.05
T	0.25±0.05
E	1.75±0.1
F	3.50±0.05
D0	1.55±0.05
D1	1.00(MIN)
W	8.00±0.1
10P0	40.00±0.2

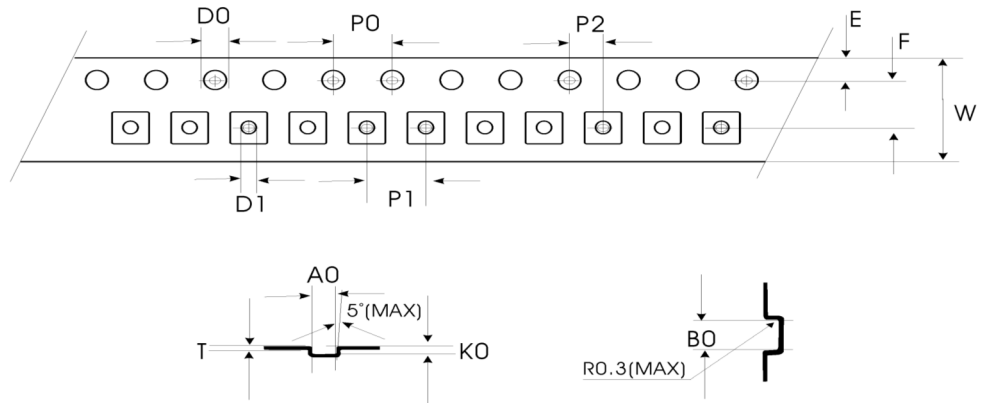

Reel Dimensions 卷轴尺寸

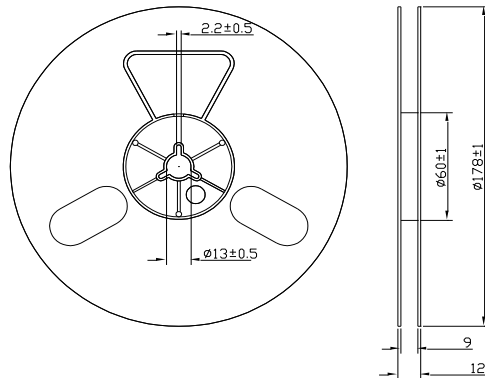

Moisture Resistant Packaging 防潮带包装

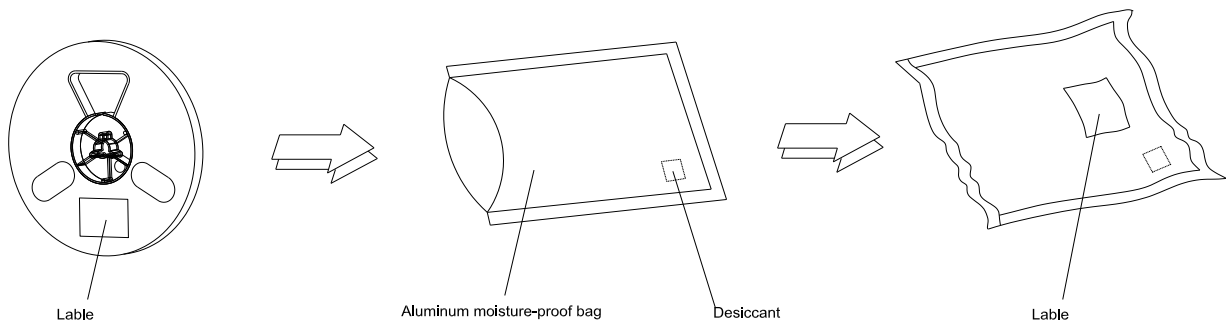



Packing



Reel: 3000pcs
Min : 500pcs/R

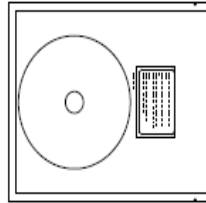
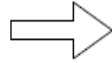

1Reel/MBB anti-static moisture-proof

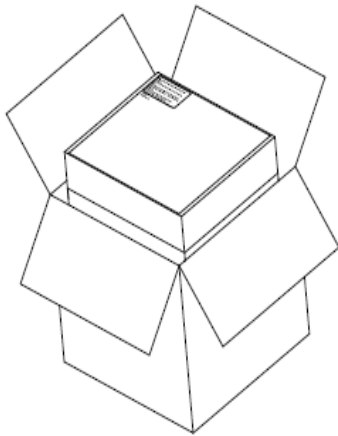

5 Inner Box/Outer Box:75000pcs

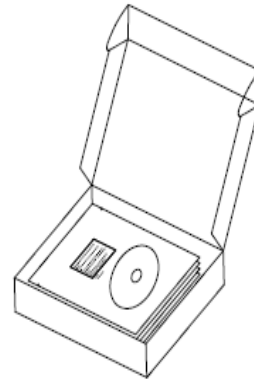

5 Bags/Inner box:15000pcs

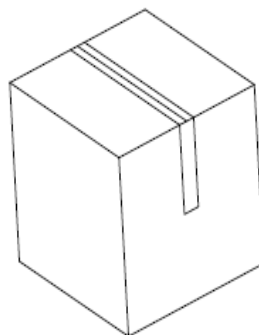
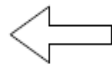

Carton



Precaution for use

1.Storage

To avoid the moisture penetration ,we recommend storing LEDs in a dry box (or a desiccators) with a desiccant. The recommended conditions are temperature 5~30 °C, Humidity 60% maximum.

2.Aafter opening packing

2.1.Soldering should be done right after opening the package (within 24Hrs).

2.2.Keeping of a fraction.

-Sealing

-Temperature: 5~30°C Humidity: less than 30%

2.3.If the package has been opened more than 1 week or the color of desiccant changed, components should be baked for 12 Hrs at 60±5°C.

3.Any mechanical force or any excess vibration shall not be accepted to apply during cooling process to normal temperature after soldering.

4.Please avoid rapid cooling after soldering.

5.Components should not be mounted on warped direction of PCB.

6.This device should not be used in any fluid such as water, oil ,organic solvent etc.

7.When the LEDs are illuminating, operating current should be decided after considering the package maximum temperature.

8.Avoid touching Lens parts especially by sharp tools such as pincette.

9.Please do not force impact or pressure diagonally on the silicone lens. It will cause fatal damage on this product.

10.Please do not cover the silicone resin of the LEDs with other resin.

11.Do not use metal suction nozzle, rubber or silica gel suction nozzle is recommended.

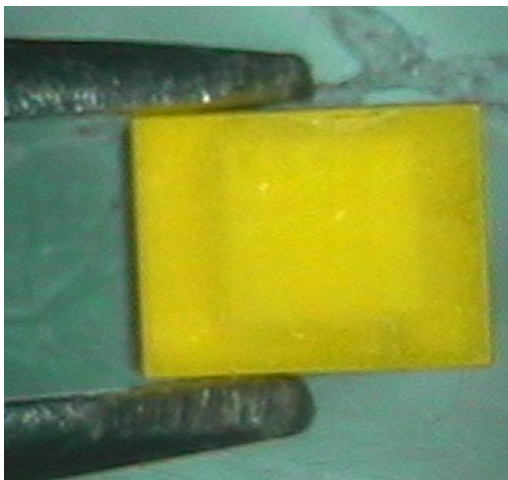

OK

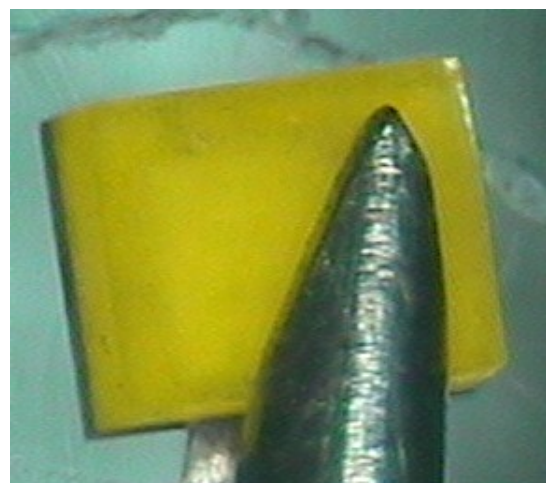

NG