

REVISIONS				
ZONE	REV	DESCRIPTION	DATE	APPROVED
	A	RELEASED	03/22/2000	B. RABBITT

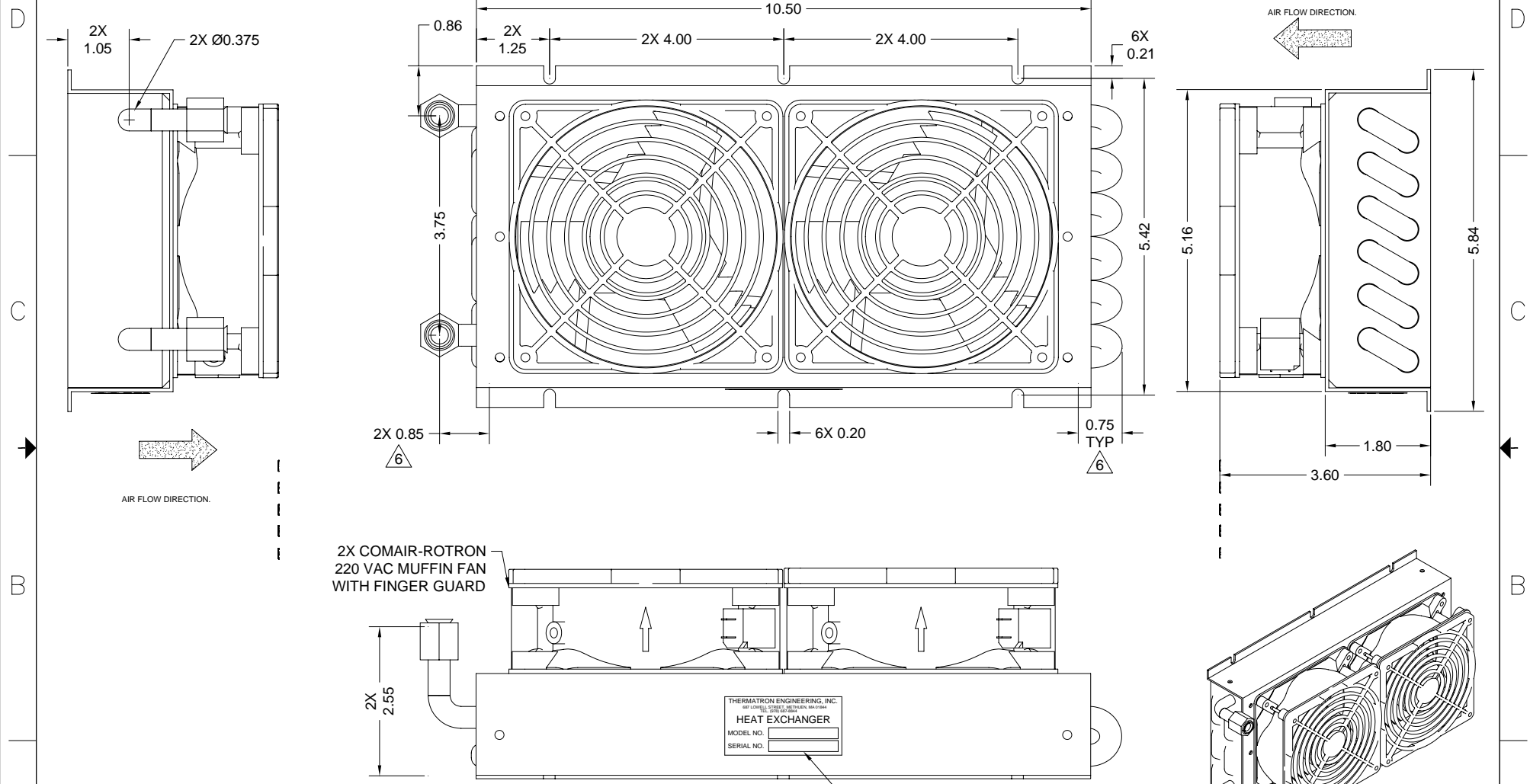

- NOTES:
1. WELD PER A8381.
 2. PRESSURE TEST 150 PSI N2 UNDER WATER.
 3. BRIGHTEN FINS PRIOR TO FRAME ASS'Y PER. TEP 101-06.
 4. INTERNAL FLUSH AND TUBE TREAT PER TEP 101-07.
 5. FRAME FINISH GOLD IRRIDITE PER. MIL-C-5441.
 6. DIMENSION FROM TUBE SHEET.

APPLY LABEL WHERE SHOWN,
MARK WITH DATE CODE AND
MODEL NUMBER

CONFIDENTIAL INFORMATION	DRAWN BY: J. RUBITSKI	DATE: 03/22/2000	THERMATRON ENGINEERING Inc. 487 LOWELL STREET, METHUEN MA 01844 * PHONE (978) 687-8844 FAX (978) 687-8844 E-MAIL: INFO@THERMATRONENG.COM * Web Site: HTTP://WWW.THERMATRONENG.COM
	CHECKED BY: B. RABBITT	DATE: 03/22/2000	
	APPROVED BY: B. RABBITT	DATE: 03/22/2000	
THIS DRAWING CONTAINS INFORMATION THAT IS RESTRICTED. USE OF THE INFORMATION CONTAINED HEREIN WITHOUT THE EXPRESS CONSENT OF THERMATRON ENGINEERING IS STRICTLY PROHIBITED.	MATERIAL: CU FIN, STAINLESS TUBE FINISH.	TITLE: HEAT EXCHANGER	
UNLESS OTHERWISE SPECIFIED, DIMENSIONS ARE IN INCHES.	THIRD ANGLE PROJECTION	CODE INDET. No. 1GQ06	DRAWING No. 731TNM2
REFERENCE No.	TOLERANCE DECIMALS: .XX ± 0.015 .XXX ± 0.010 ANGLES: ± 1/2	DRAWING SIZE: C	SCALE: 1:1 SHEET: 1 OF 1