

REVISIONS				
ZONE	REV	DESCRIPTION	DATE	APPROVED
	A	UPDATE TO CAD 2000, NO CHANGE.	05/17/1999	D. SAVOY

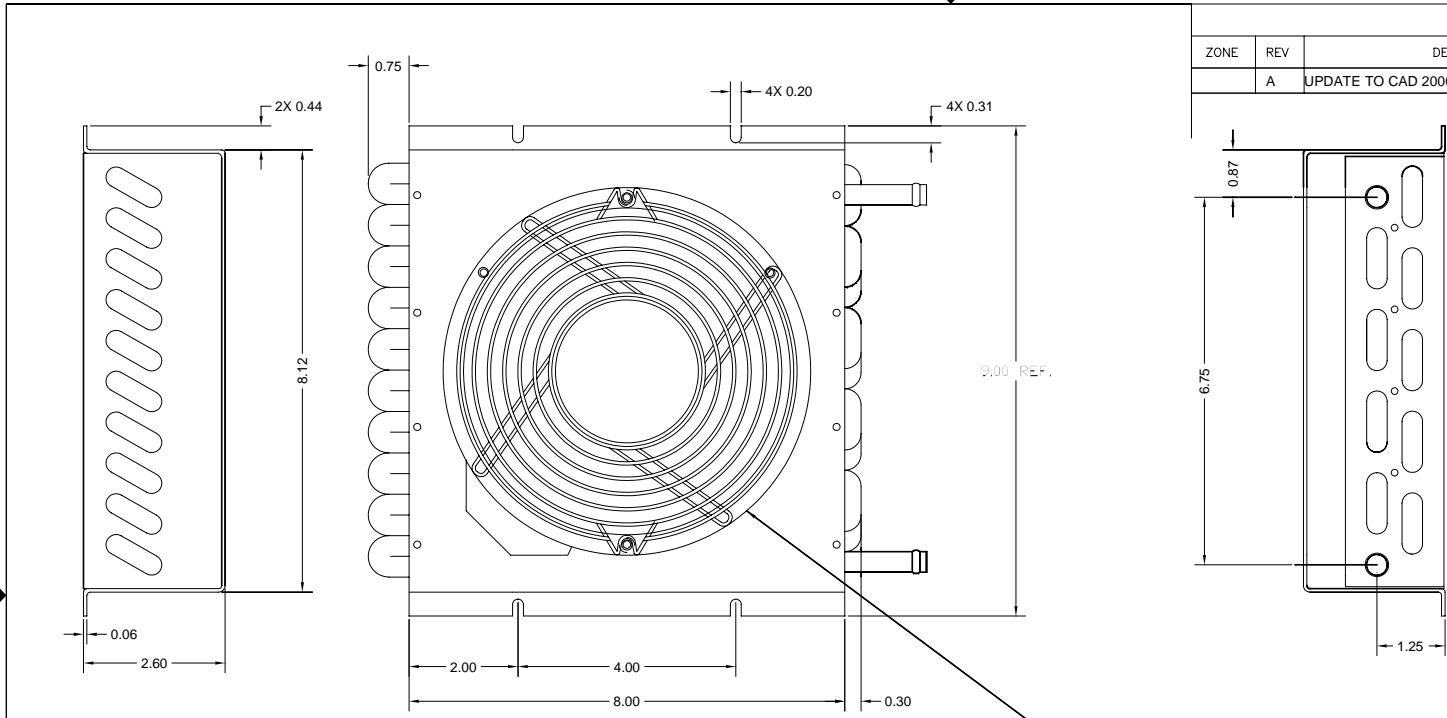

FAN: COMAIR-ROTRON PATRIOT 220 VAC  
 MODEL NO. PT77B3  
 P/N 028312  
 FINGER GUARD: P/N 551199

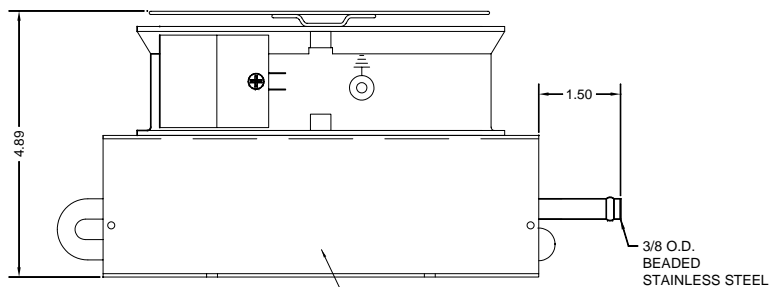

- NOTES:
- ▲ FRAME FINISH GOLD IRRIDITE PER. MIL-C-5441
  - ▲ WELD PER A8381
  - ▲ PRESSURE TEST 150 PSI N2 UNDER WATER
  - ▲ BRIGHTEN FINS PRIOR TO FRAME ASS'Y PER. TEP 101-06
  - ▲ INTERNAL FLUSH AND TUBE TREAT PER. TEP 101-07

<b>CONFIDENTIAL INFORMATION</b>	DRAWN BY. B. RABBITT	DATE. 05/17/1999	<b>THERMATRON ENGINEERING Inc.</b> 687 LOWELL STREET, METHUEN MA 01844 * PHONE (978)-687-8844 FAX (978)-687-8844 E-Mail: INFO@THERMATRONENG.COM * Web Site: HTTP://WWW.THERMATRONENG.COM
	CHECKED BY. D. SAVOY	DATE. 05/17/1999	
	APPROVED BY. D. SAVOY	DATE. 05/17/1999	
	MATERIAL. STAINLESS TUBING / CU FINS FINISH.		
THIS DRAWING CONTAINS INFORMATION THAT IS RESTRICTED. USE OF THE INFORMATION CONTAINED HEREIN WITHOUT THE EXPRESS CONSENT OF THERMATRON ENGINEERING IS STRICTLY PROHIBITED.		TITLE: <b>HEAT EXCHANGER</b>	
REFERENCE No. OLD No. 9159	TOLERANCE DECIMALS: .XX ± 0.050 .XXX ± 0.025	CODE INDET. No. <b>1GQ06</b>	DRAWING No. <b>732SBP2</b>
NEXT ASSEMBLY. NONE	ANGLES: ± 1/2	DRAWING SIZE. <b>B</b>	
		THIRD ANGLE PROJECTION	SCALE. 1:1
		SHEET. 1 OF 1	