

# PRODUCT SPECIFICATION

**Model No.: FYL-5013GT1C-20**

Descriptions:
■Dice material: GaP
■Emitting Color: Green
■Device Outline: Φ5mm round type.
■Lens Type: Green Transparent.



CUSTOMER APPROVED SIGNATURES	APPROVED BY	CHECKED BY	PREPARED BY

**NINGBO FORYARD OPTOELECTRONICS CO.,LTD.**

**Add:**NO.115 Qixin Road Ningbo Zhejiang China

**Zip:**315051

**Tel:** 0086-574-87933652 87927870 87922206

**Fax:** 0086-574-87927917

**E-mail:** Sales@foryard.com (General)

**Http://**[www.foryard.com](http://www.foryard.com)

Model. No.	FYL-5013GT1C-20
Rev.	A

## ■ Features

1. Low power consumption.
2. High efficiency.
3. General purpose leads.
4. RoHs compliant.

## ■ Package configuration

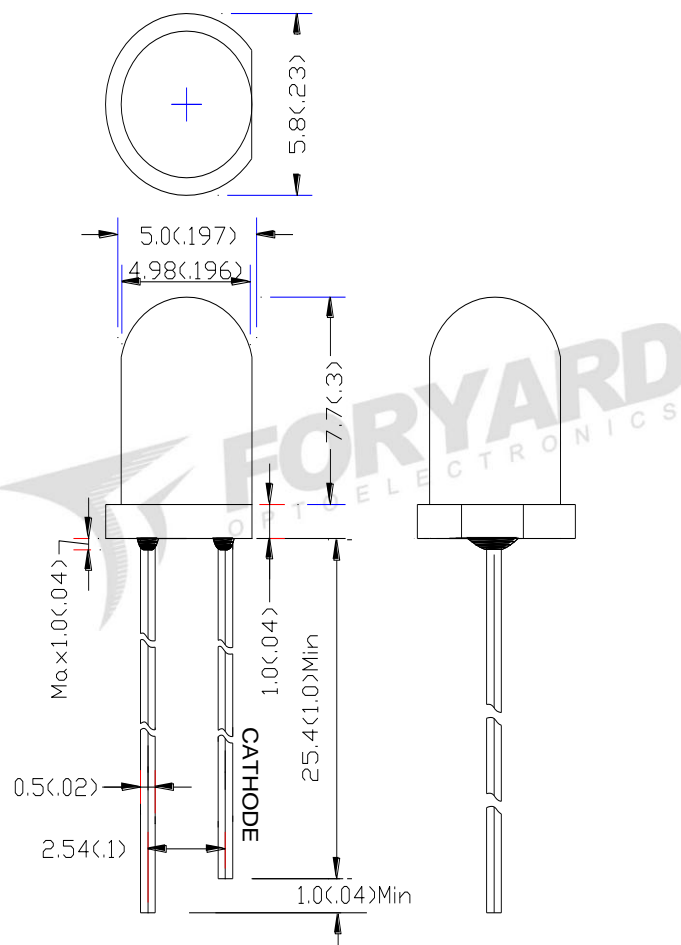

### Notes:

1. All dimensions are millimeters (inches)
2. Tolerance is  $\pm 0.25\text{mm} (.010\text{'})$  unless otherwise noted.
3. The specifications, characteristics and technical data described in the datasheet are subject to change without prior notice.

■ Absolute maximum ratings( $T_a=25\text{ }^\circ\text{C}$ )

Parameter	MAX.	Unit
Power Dissipation	75	mW
Peak Forward Current (1/10 Duty Cycle, 0.1ms Pulse Width)	100	mA
Continuous Forward Current	30	mA
Derating Linear From 50 $^\circ\text{C}$	0.4	mA/ $^\circ\text{C}$
Reverse Voltage	5	V
Operating Temperature Range	-20 $^\circ\text{C}$ to +80 $^\circ\text{C}$	
Storage Temperature Range	-30 $^\circ\text{C}$ to +100 $^\circ\text{C}$	
Lead Soldering Temperature[4mm(.157") From Body]	260 $^\circ\text{C}$ for 5 Seconds	

■ Electrical and optical characteristics( $T_a=25\text{ }^\circ\text{C}$ )

Parameter	Symbol	Min.	Typ.	Max.	Unit	Test Condition
Luminous Intensity	$I_v$	40	80	-	mcd	$I_F=20\text{mA}$
Viewing Angle	$2\theta_{1/2}$	-	20	-	Deg	
Peak Emission Wavelength	$\lambda_p$	563	568	573	nm	
Dominant Wavelength	$\lambda_d$	565	570	575	nm	
Spectral Line Half-Width	$\Delta\lambda$	-	20	-	nm	
Forward Voltage	$V_F$	1.8	2.1	2.5	V	
Reverse Current	$I_R$			10	$\mu\text{A}$	$V_R=5\text{V}$

## ■ Typical Electrical Characteristics Curves

(25 ° c Ambient Temperature Unless Otherwise Noted)

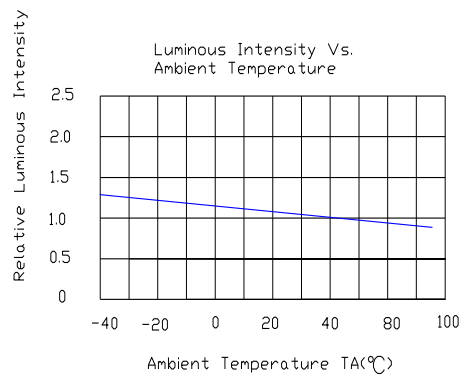
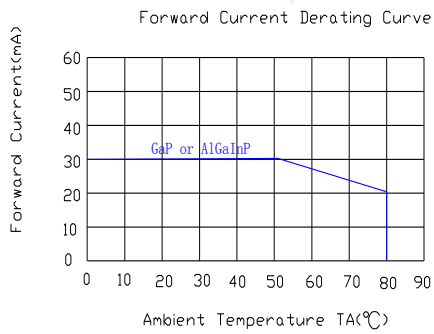
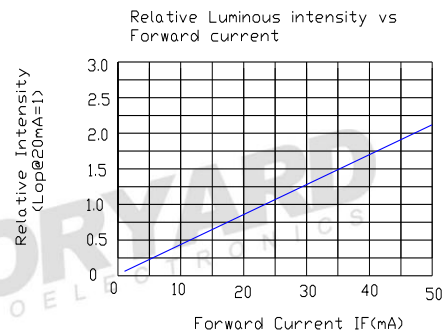
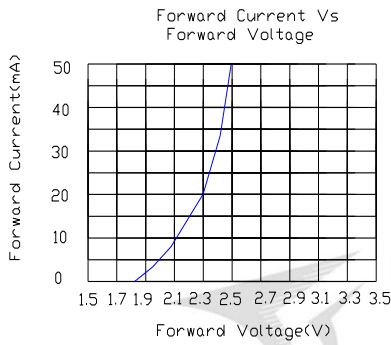
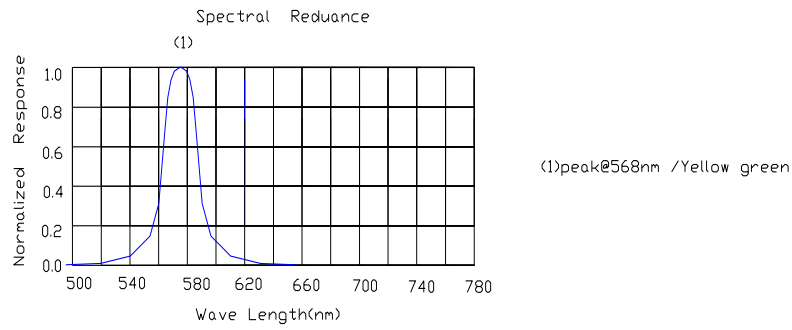

## Radiation pattern.

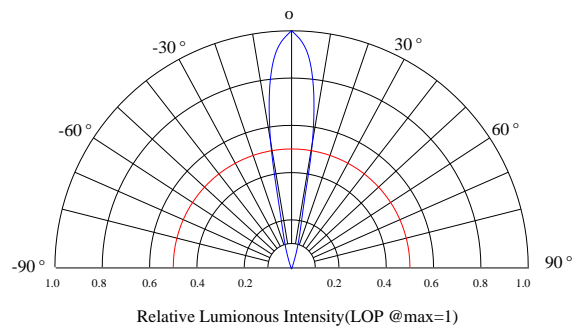

Model No.	FYL-5013GT1C-20
Rev.	A

■ LAMP PACKING.

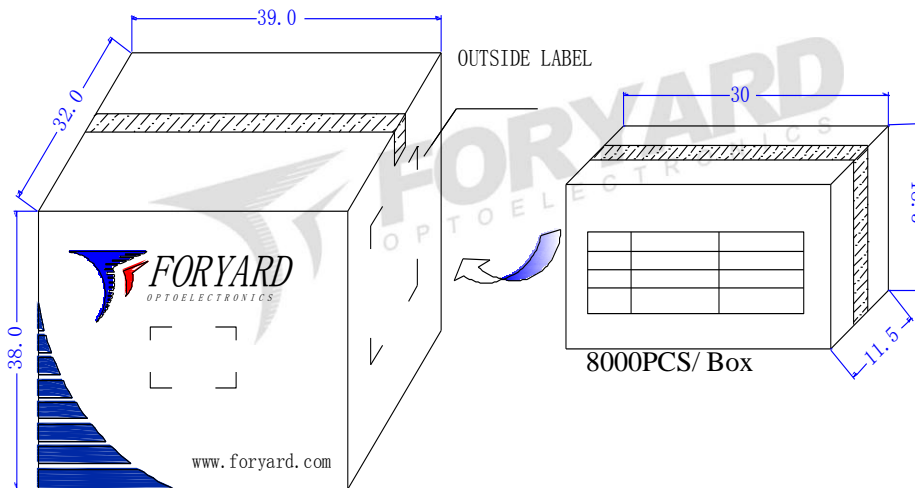
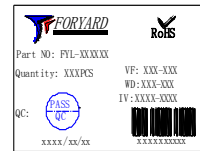
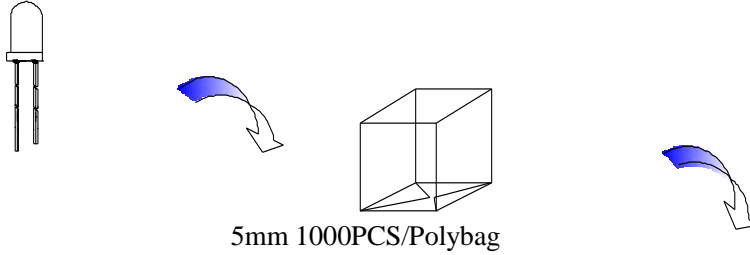

48000PCS/ Carton

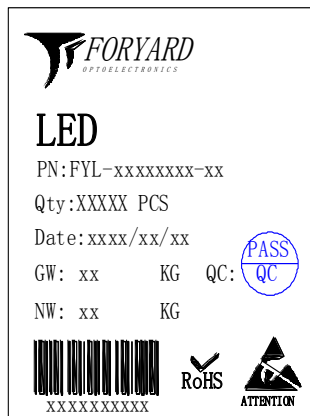

OUTSIDE LABEL