

| Rev. No. | Revision note | Date | Signature | Checked |
|----------|-----------------|------------|-----------|----------|
| A | Initial version | 2018-03-12 | | James Hu |
| | | | | |
| | | | | |
| | | | | |

I、Winding details

| No. | S - F | WIRE SIZE | WINDING TURNS | NOTE |
|-----|-------|------------------|---------------|------|
| N1 | S-F | φ 0.20mm/2UEW×1P | 90.5Ts | |

III、Note

- 1.All material meet RoHS complaint .
- 2.Ferrite Drum core .
- 3.Unit in mm.
- 4.Temperature rise:20 °C max. at rated current.

II.Electrical parameters

| | Test Item | Test PIN | Specification value | Test condition | Test equipment |
|---|----------------------|----------|---------------------|----------------|-------------------|
| 1 | Inductance | S-F | 220uH±10% | 1KHz/0.30V | LCZ bridge tester |
| 2 | DCR | S-F | 0.90 Ω max | @25°C | TH251 DCR tester |
| 3 | IDC | | 240mA max | | |
| 4 | Storage conditions | | -40 °C to 105 °C; | | |
| 5 | Operating conditions | | -40 °C to 105 °C; | | |

IV、Electrical diagram

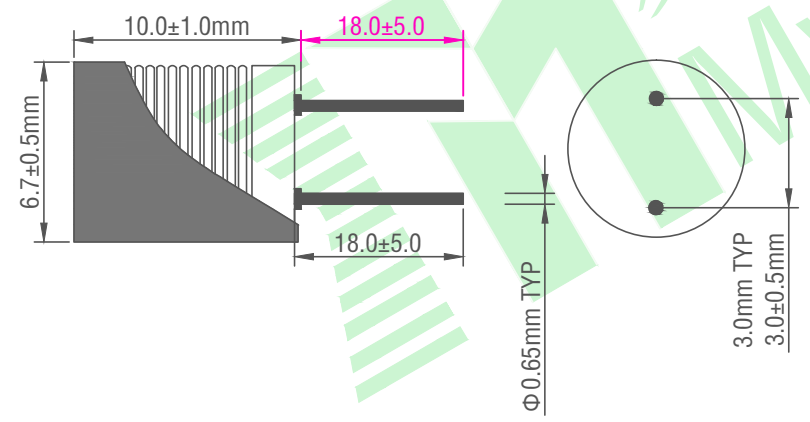
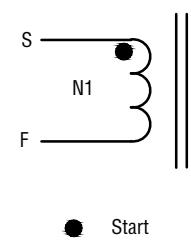

Package label:

PN: RLB0712-221KL
 QTY: 500pcs
 Date: YYWW

RoHS

| | | | | |
|--|------------------------|-------------------------|--|-----------------------------|
| Website: www.mycoiltech.com Email: sales@mycoiltech.com Tel: +86 551 6619 6829 | | | | |
| Drawn by James Hu | Checked by James Hu | Approved by James Hu | 合肥麦可一科技有限公司 HeFei Mycoil Technology Co.,Ltd | Accession No. MCT021DA53 |
| MCT Part No. RLB0712-221KL | | | ADD:The HaiLiang Blue County Garden,Dongpu Road,Luyang District,Hefei City, 230022,China | Edition A |
| | | | | |