



UA8229

LINEAR INTEGRATED CIRCUIT

LOW FREQUENCY POWER AMPLIFIER

DESCRIPTION

The UTC **UA8229** is a low frequency power amplifier and developed for portable radio cassette tape recorder with power ON/OFF switch.

The audio power IC has built-in two channels and thermal shut down protection circuit.

FEATURES

- * High Power
 - : $P_{OUT(1)} = 2.5W$ (Typ.)
($V_{CC} = 9V, R_L = 4\Omega, f = 1kHz, THD = 10\%$)
 - : $P_{OUT(2)} = 4.6W$ (Typ.)
($V_{CC} = 12V, R_L = 4\Omega, f = 1kHz, THD = 10\%$)
- * Low Popping Noise at Power ON
- * Small Quiescent Current
 - : $I_Q = 21mA$ (Typ.) ($V_{CC} = 15V, V_{IN} = 0$)
- * Soft Clip
- * Thermal Shut Down Protection
- * Best for Supply Voltage 9V, 12V
- * Operation Supply Voltage Range from 6V to 15V

ORDERING INFORMATION

Ordering Number		Package	Packing
Normal	Lead Free Plating		
UA8229-H14-B-T	UA8229L-H14-B-T	HSIP-14B	Tube
UA8229-J15-A-T	UA8229L-J15-A-T	HZIP-15A	Tube

UA8229L-H14-B-T

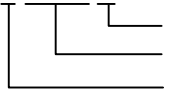

- (1) Packing Type
- (2) Package Type
- (3) Lead Plating

- (1) T: Tube
- (2) H14-B: HSIP-14B, J15-A: HZIP-15A
- (3) Lead Free Plating, Blank: Pb/Sn

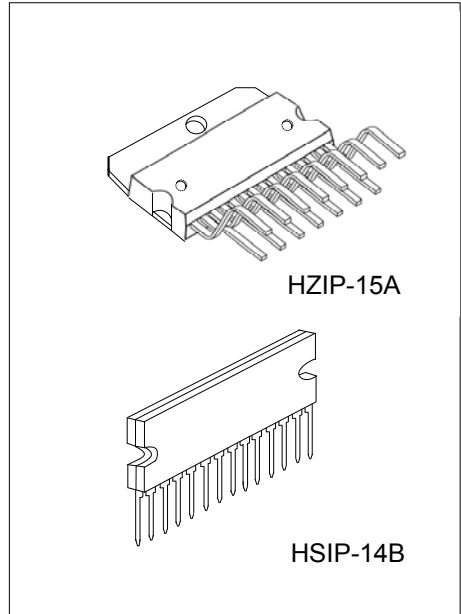

*Pb-free plating product number: UA8229L

■ PIN CONFIGURATIONS

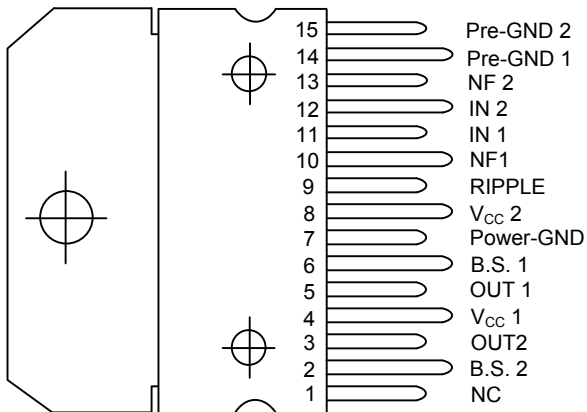

HZIP-15A

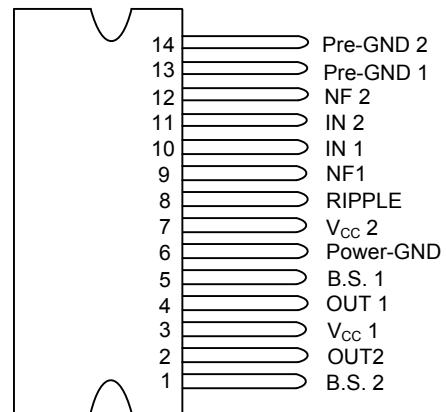

HSIP-14B

■ BLOCK DIAGRAMS
FOR HSIP-14B PACKAGE

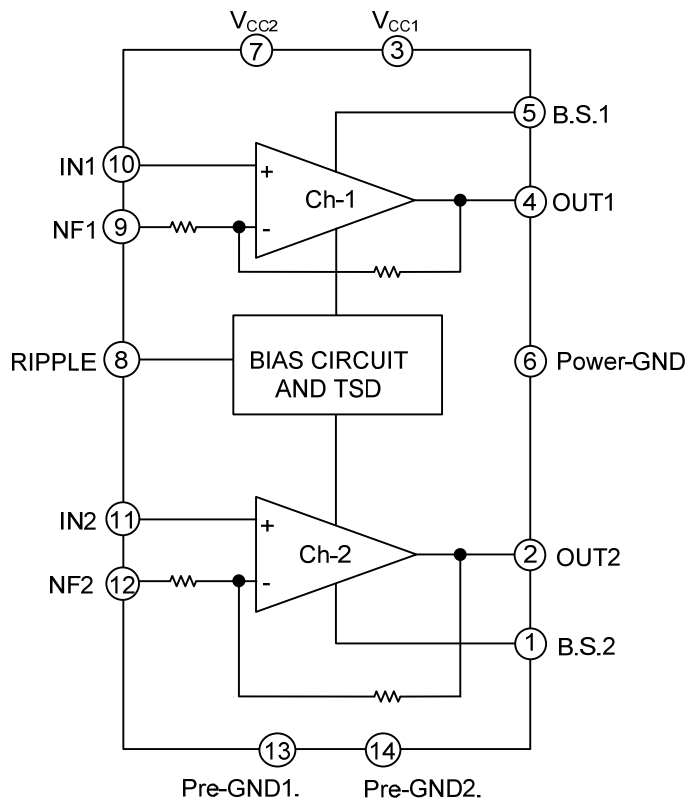

FOR HZIP-15A PACKAGE

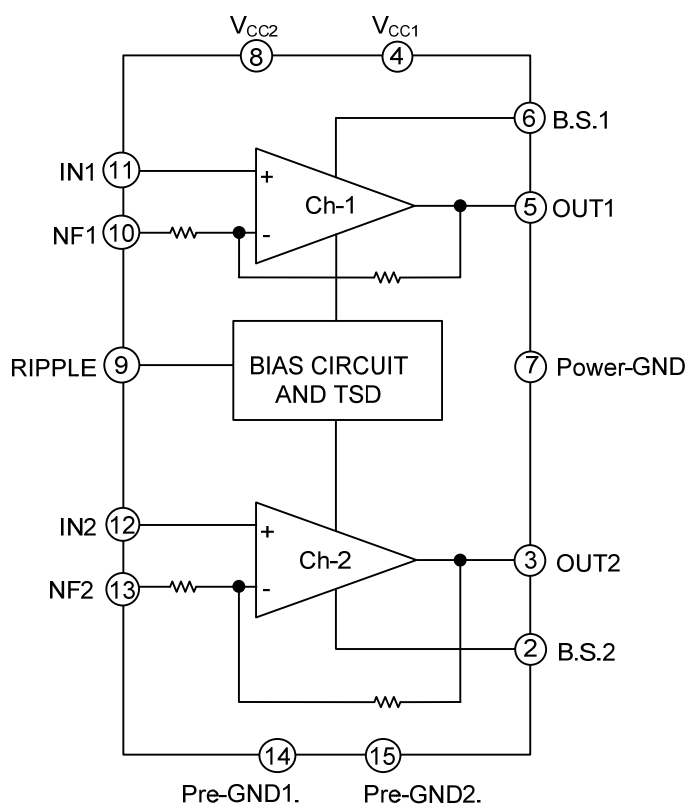

■ ABSOLUTE MAXIMUM RATINGS (Ta = 25°C)

PARAMETER	SYMBOL	RATINGS	UNIT
Supply Voltage	V _{CC}	20	V
Peak Output Current	I _{O(PEAK)}	2.5	A
Power Dissipation	P _D	15	W
Derated above Ta = 25°C		120	
Operating Temperature	T _{OPR}	-20 ~ +85	°C
Storage Temperature	T _{STG}	-40 ~ +150	°C

Note 1. Absolute maximum ratings are those values beyond which the device could be permanently damaged. Absolute maximum ratings are stress ratings only and functional device operation is not implied.

2. The device is guaranteed to meet performance specification within 0°C ~ +70°C operating temperature range and assured by design from -20°C ~ +85°C.

■ ELECTRICAL CHARACTERISTICS

(Ta=25°C, V_{CC}=9V, R_L=4Ω, R_g=600Ω, f=1kHz, R_F=120Ω, unless otherwise specified.)

PARAMETER	SYMBOL	TEST CONDITIONS	MIN	TYP	MAX	UNIT
Input Offset Voltage	V ₁₁ , V ₁₂			30	60	mV
Stand-by Current	I _{STN-BY}	SW1 → OFF		1		μA
Quiescent Current	I _D	V _{IN} = 0		25	45	mA
Output Power	P _{OUT(1)}	THD = 10%, V _{CC} =9V	2.0	2.5		W
	P _{OUT(2)}	THD = 10%, V _{CC} = 12V		4.6		
Total Harmonic Distortion	THD	P _{OUT} = 0.4W/ch		0.2	1.0	%
Voltage Gain	G _{V(1)}	R _F = 120Ω, V _{OUT} = 0.775Vrms (0dBm)	43	45	47	dB
	G _{V(2)}	R _F = 0, V _{out} = 0.775Vrms (0dBm)		56.5		
Input Resistance	R _{IN}			30		kΩ
Output Noise Voltage	V _{NO}	R _G = 10kΩ, BW = 20Hz ~ 20kHz		0.3	1.0	mVrms
Ripple Rejection Ratio	RR	R _G = 600Ω, f _{RIPPLE} = 100kHz		-52		dB
Cross Talk	C.T.	R _G = 600Ω, amp1 ↔ 2 V _{OUT} = 0.775Vrms (0dBm)		-50		dB

■ TEST CIRCUITS

FOR HSIP-14B PACKAGE

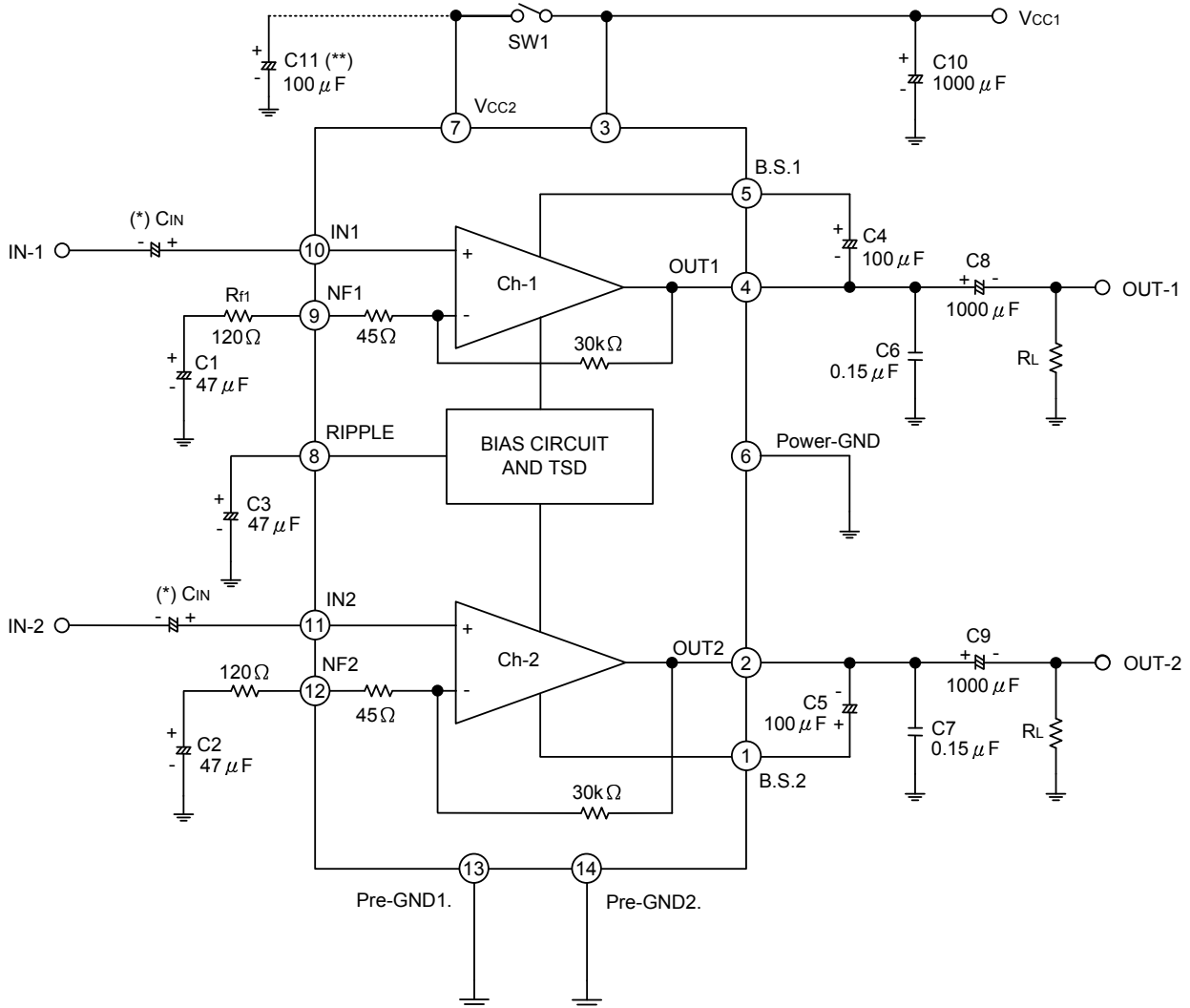

(*) This IC can be used without coupling capacitor (C_{IN}).

If volume slide noise occurred by input offset voltage is undesirable, it needs to use the capacitor (C_{IN}).

(**) The condenser between the pin 8 and the GND (C_{11}) is for reducing POP noise when the power ON/OFF switch (SW1) is set to ON/OFF.

■ TEST CIRCUITS(Cont.)

FOR HZIP-15A PACKAGE

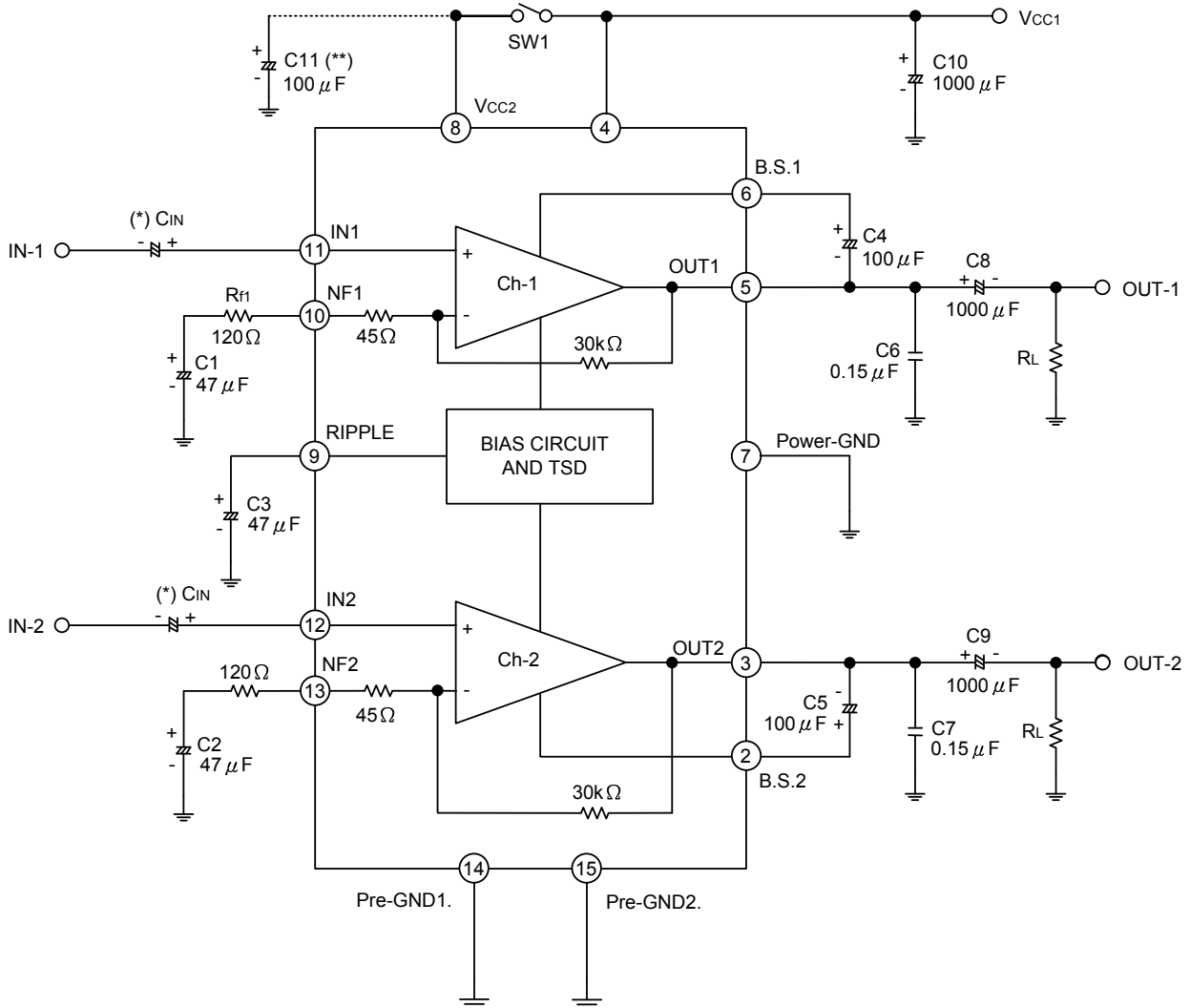

(*) This IC can be used without coupling capacitor (C_{IN}).

If volume slide noise occurred by input offset voltage is undesirable, it needs to use the capacitor (C_{IN}).

(**) The condenser between the pin 9 and the GND (C_{11}) is for reducing POP noise when the power ON/OFF switch (SW1) is set to ON/OFF.

APPLICATION INFORMATION

1. Adjustment of voltage gain

The voltage gain G_V is obtained by R_1 , R_2 and R_F as below. By increasing R_F , reduction of G_V is possible. 40dB or over in use is recommended.

$$G_V = 20 \log \frac{R_F + R_1 + R_2}{R_F + R_1}$$

Sine oscillation is probable as a result of feedback in crease.

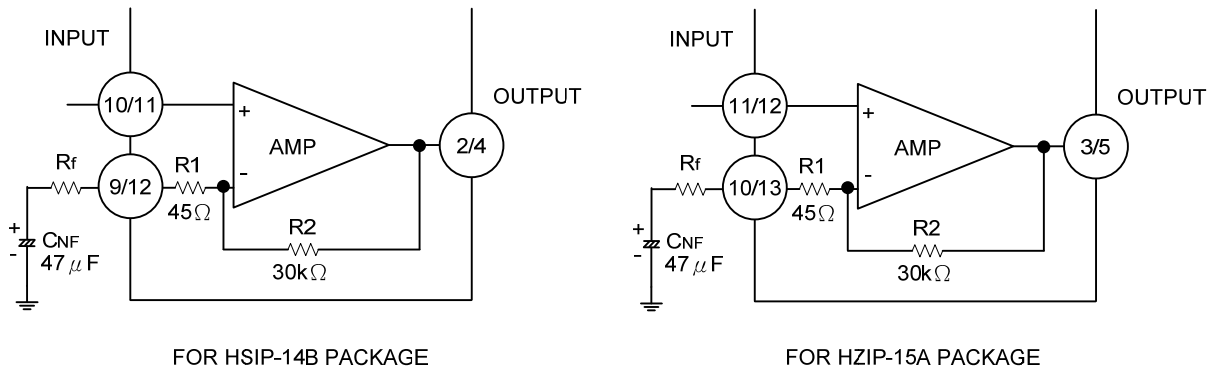

Fig.1

2. Input stage

The input circuit of this IC is as shown as below.

PNP TR: TR1 is provided in the input circuit so as to make its usage possible without the input coupling capacitor. However, at Pin 10 and Pin 11 max 60 mV offset voltage is produced.

Fig.2 illustrate the input circuit of UTC UA8229. A offset voltage of 60mV max is possible. TR1 is featured to eliminate the usage of coupling capacitor.

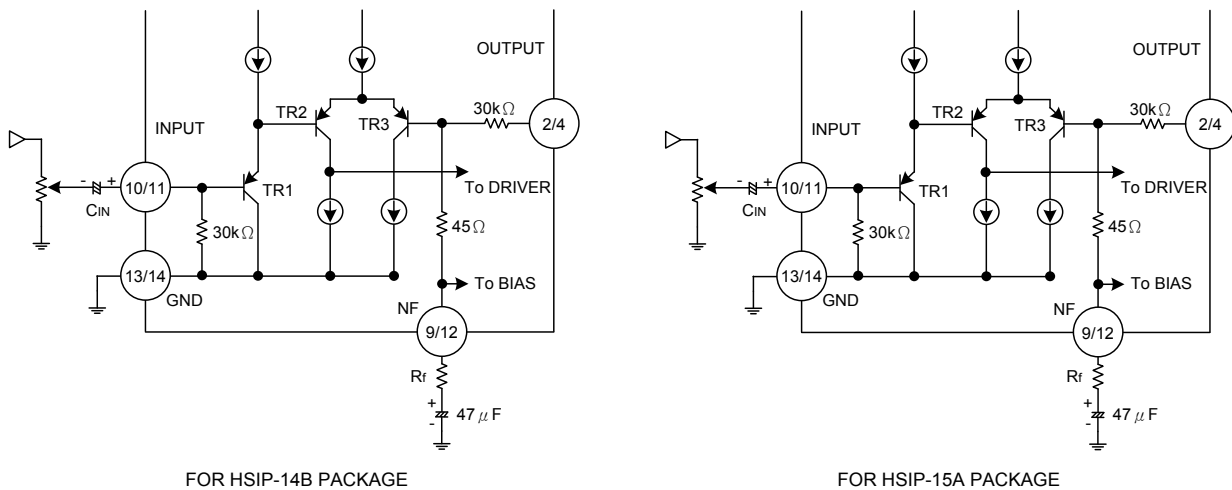

Fig. 2

■ APPLICATION INFORMATION(Cont.)

3. Input voltage

When the excessive signal is input, turning-up is produced in the clip waveform.

4. Oscillation preventive measures

Mylar capacitor in use is strongly recommended to fulfill well handled of oscillation temperature and high frequency.

5. Power ON/OFF switch

There is power ON/OFF switch at Pin 7(HZIP-15A's Pin 8). However, output power is changed by Pin 7(HZIP-15A's Pin8) supply voltage when Pin 7(HZIP-15A's Pin 8) supply voltage is not same Pin 3(HZIP-15A's Pin 4) supply voltage, after referring to attached date, select Pin 7 (HZIP-15A's Pin 8)supply voltage.

6. Thermal shut-down Protection

The thermal shut-down circuit is built-in to dodge IC damage that result from the abnormal temperature rise during operating.

■ TYPICAL CHARACTERISTICS

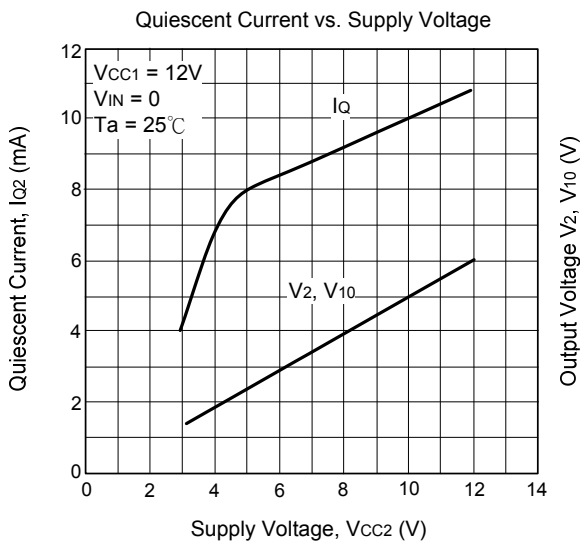
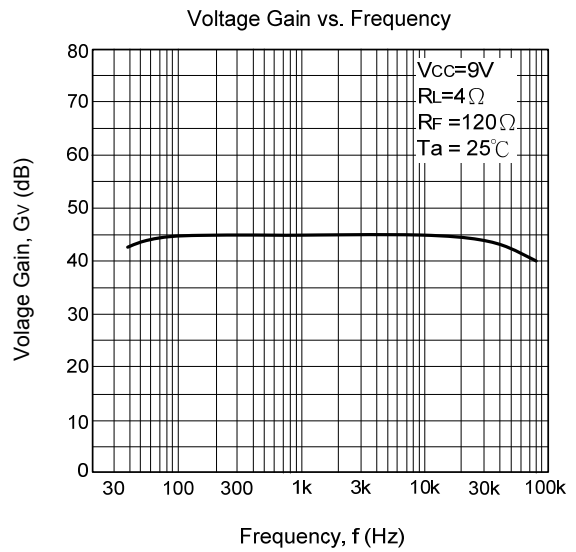
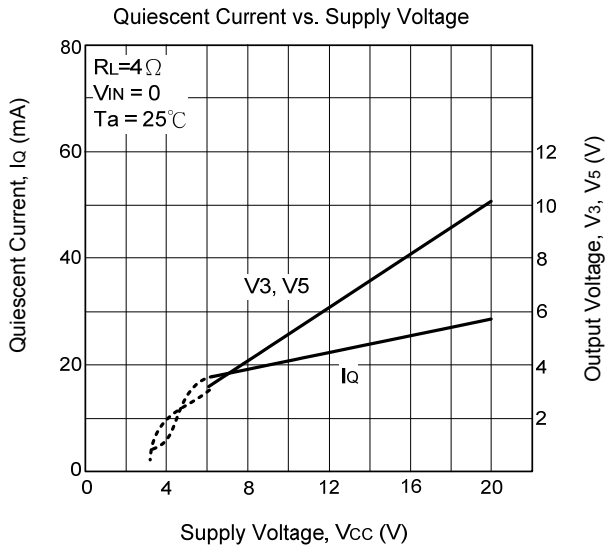

UTC assumes no responsibility for equipment failures that result from using products at values that exceed, even momentarily, rated values (such as maximum ratings, operating condition ranges, or other parameters) listed in products specifications of any and all UTC products described or contained herein. UTC products are not designed for use in life support appliances, devices or systems where malfunction of these products can be reasonably expected to result in personal injury. Reproduction in whole or in part is prohibited without the prior written consent of the copyright owner. The information presented in this document does not form part of any quotation or contract, is believed to be accurate and reliable and may be changed without notice.