

PROGRAMMABLE PRECISION SHUNT REGULATOR LM431/A/C

FEATURES

- Programmable Output Voltage to 40V
- Guaranteed 0.5% Reference Voltage Tolerance
- Low (0.2Ω Typ.) Dynamic Output Impedance
- Cathode Current Range(Continuous) – 100 ~ 150 mA
- Equivalent Full Range Temperature Coefficient of 50PPM/°C
- Temperature Compensated For Operation Over Full Rate Operating Temperature Range
- Low Output Noise Voltage
- Fast Turn-on Response
- SOT-23 3L Package

APPLICATION

- Shunt Regulator
- Precision High-Current Series Regulator
- High-Current Shunt Regulator
- Crowbar Circuit
- PWM Converter With Reference
- Voltage Monitor
- Precision Current Limiter



ORDERING INFORMATION

DEVICE	PACKAGE
LM431SF	SOT-23 3L

* Refer to the page 2 for detailed ordering Information,

DESCRIPTION

The LM431 is a three-terminal adjustable shunt regulator with specified thermal stability over applicable temperature V_{REF} (Approx. 2.5V) and 40V with two external resistors. This device has a typical dynamic output impedance of 0.2Ω. Active output circuitry provides a very sharp turn-on characteristic, making this device excellent replacement for zener diodes in many applications. The LM431 is characterized for operation from -40°C to +125°C.

ABSOLUTE MAXIMUM RATINGS

(Operating temperature range applies unless otherwise specified)

CHARACTERISTIC	SYMBOL	MIN.	MAX.	UNIT
Cathode Voltage	V_{KA}	-	42	V
Cathode Current Range(Continuous)	I_K	-100	150	mA
Reference Input Current Range	I_{REF}	-0.05	10	mA
Junction Temperature Range	T_J	-40	150	°C
Operating Temperature Range	T_{OPR}	-40	125	°C
Storage Temperature Range	T_{STG}	-60	150	°C

PROGRAMMABLE PRECISION SHUNT REGULATOR LM431/A/C

RECOMMENDED OPERATING CONDITIONS

CHARACTERISTIC	SYMBOL	MIN.	MAX.	UNIT
Cathode Voltage	V_{KA}	V_{REF}	40	V
Cathode Current	I_K	0.5	100	mA

ORDERING INFORMATION

Package	Tolerance	Order No.	Package Marking	Supplied As	Status
SOT-23	0.5%	LM431CSF	431O	Reel	Active
	1 %	LM431ASF	431O	Reel	Active

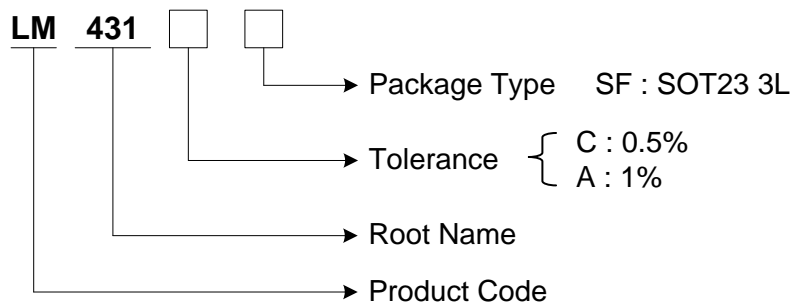

PIN CONFIGURATION

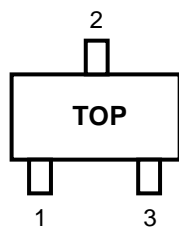

SOT-23 PKG

PIN DESCRIPTION

Pin No.	SOT-23	
	Name	Function
1	Cathode	Input Supply Voltage
2	Anode	Ground
3	Reference	Reference Voltage

PROGRAMMABLE PRECISION SHUNT REGULATOR LM431/A/C

LM431 ELECTRICAL CHARACTERISTICS

($T_A=25^\circ\text{C}$, unless otherwise specified)

CHARACTERISTIC	SYMBOL	TEST CONDITION	MIN.	TYP.	MAX.	UNIT	
Reference Voltage	V_{REF}	$V_{KA}=V_{REF}$, $I_K=10\text{mA}$	0.5 %	2.487	2.500	2.512	V
			1 %	2.475	2.500	2.525	
Deviation of Reference Voltage	$\Delta V_{REF}/\Delta T$	$V_{KA}=V_{REF}$, $I_K=10\text{mA}$ $T_A=\text{Full Range}$		8	20	mV	
Ratio of Change in Reference Voltage to the Change in Cathode Voltage	$\Delta V_{REF}/\Delta V_{KA}$	$I_K=10\text{mA}$	$\Delta V_{KA}=10\text{V}-V_{REF}$		-1.4	-2.7	mV/V
			$\Delta V_{KA}=36\text{V}-10\text{V}$		-1.0	-2.0	
Reference Current	I_{REF}	$I_{KA}=10\text{mA}$, $R_1=10\text{k}\Omega$, $R_2=\infty$		1.8	4.0	μA	
Deviation of Reference Current	$\Delta I_{REF}/\Delta T$	$I_K=10\text{mA}$, $R_1=10\text{k}\Omega$, $R_2=\infty$ $T_A=\text{Full Range}$		0.4	1.2	μA	
Minimum Cathode Current for Regulation	$I_{K(\text{MIN})}$	$V_{KA}=V_{REF}$			0.5	mA	
Off-State Cathode Current	$I_{K(\text{OFF})}$	$V_{KA}=36\text{V}$, $V_{REF}=0$		0.17	0.90	μA	
Dynamic Impedance	Z_{KA}	$V_{KA}=V_{REF}$, $I_K=1\text{mA}\sim 100\text{mA}$ $f \leq 1\text{kHz}$		0.27	0.50	Ω	

TEST CIRCUITS

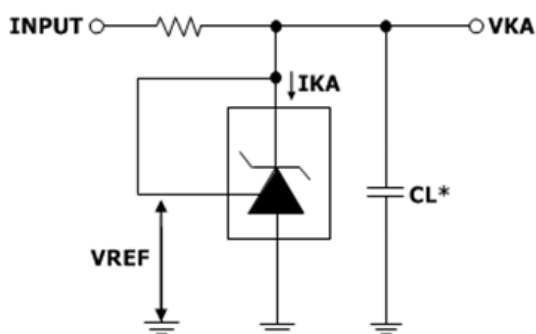

[Fig 1. Test circuit for $V_{KA} = V_{REF}$]

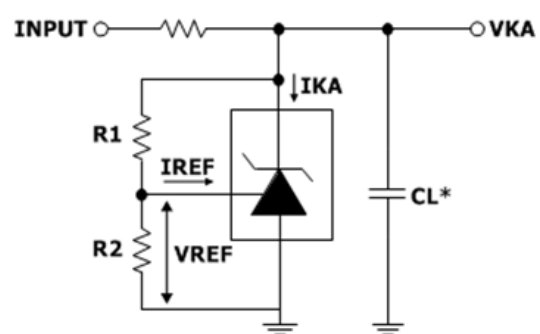

[Fig 2. Test circuit for $V_{KA} \geq V_{REF}$]

PROGRAMMABLE PRECISION SHUNT REGULATOR LM431/A/C

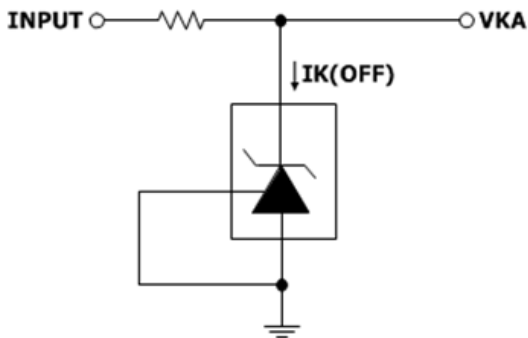

[Fig 3. Test circuit for $I_{KA(OFF)}$]

The deviation parameters $\Delta V_{REF}/\Delta T$ and $\Delta I_{REF}/\Delta T$ are defined as the differences between the maximum and minimum values obtained over the recommended temperature range. The average full-range temperature coefficient of the reference voltage, αV_{REF} , is defined as :

$$|\alpha V_{REF}| \left(\frac{\text{ppm}}{^\circ\text{C}} \right) = \frac{\left(\frac{V_{I(\text{dev})}}{V_{REF \text{ at } 25^\circ\text{C}}} \right) \times 10^6}{\Delta T_A}$$

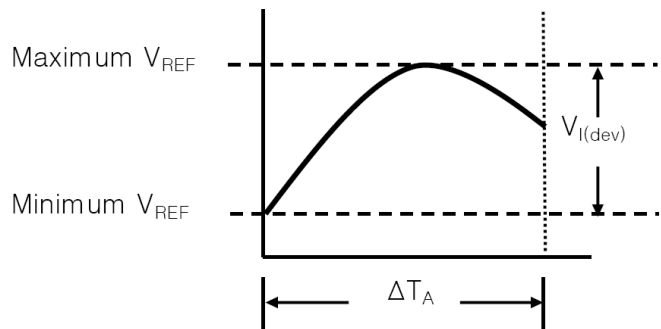

Where :

ΔT_A is the recommended operating free-air temperature range of the device.

αV_{REF} can be positive or negative, depending on whether minimum V_{REF} or maximum V_{REF} , respectively, occurs at the lower temperature.

Calculating Dynamic Impedance

The dynamic impedance is defined as : $|Z_{KA}| = \frac{\Delta V_{KA}}{\Delta I_{KA}}$

When the device is operating with two external resistors, the total dynamic impedance of the circuit is given by :

$$|Z'| = \frac{\Delta V}{\Delta I} \approx |Z_{KA}| \left(1 + \frac{R1}{R2} \right)$$

TYPICAL OPERATING CHARACTERISTICS

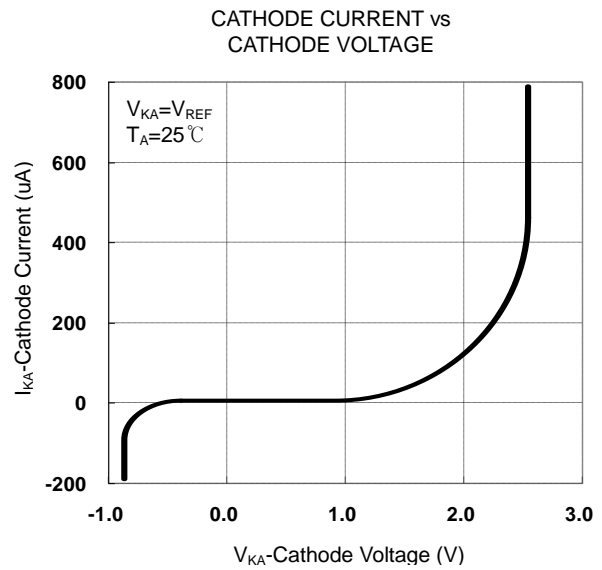
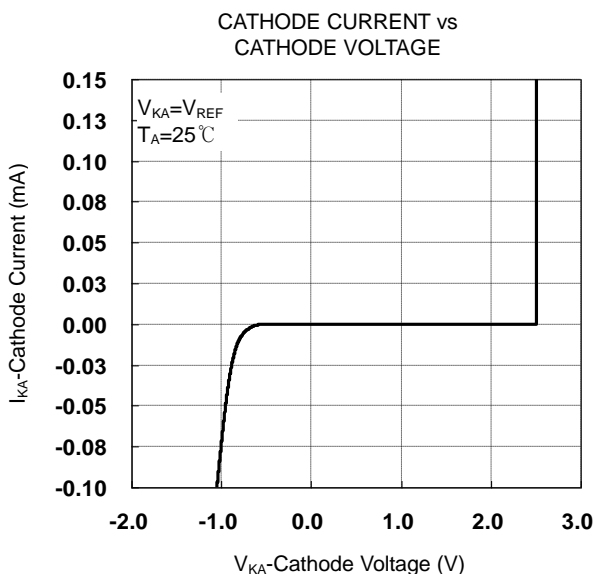
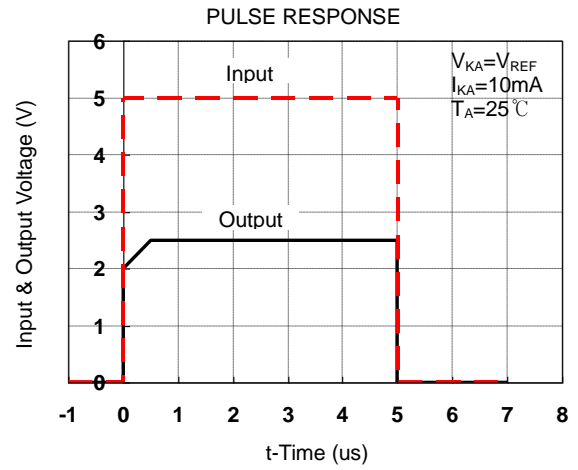
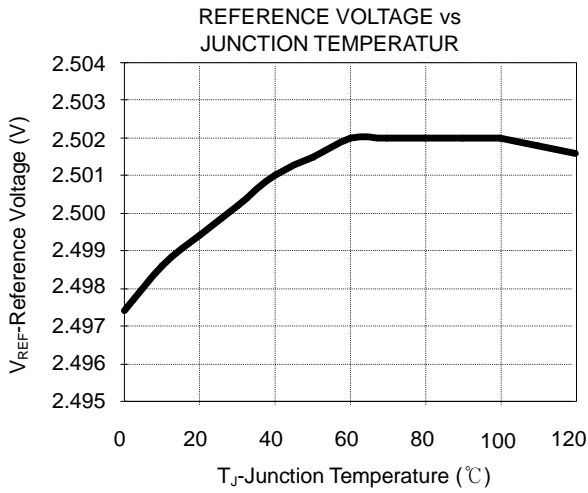

T.B.D

PROGRAMMABLE PRECISION SHUNT REGULATOR LM431/A/C

APPLICATION INFORMATION

1. Shunt Regulator

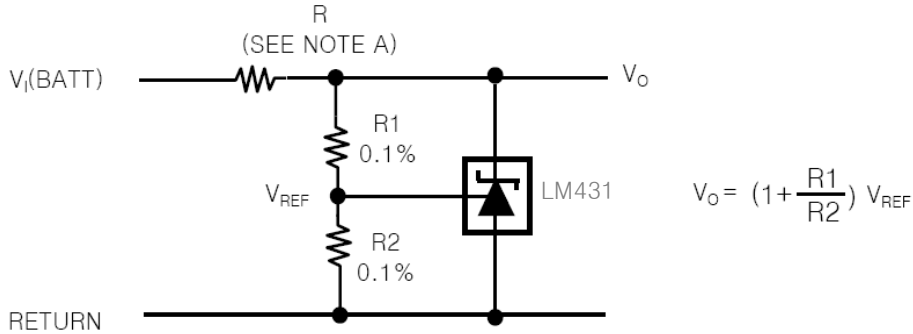

Note A : R Should provide cathode current 1mA to the LM431 at minimum $V_{I(BATT)}$

2. Precision High-Current Series Regulator

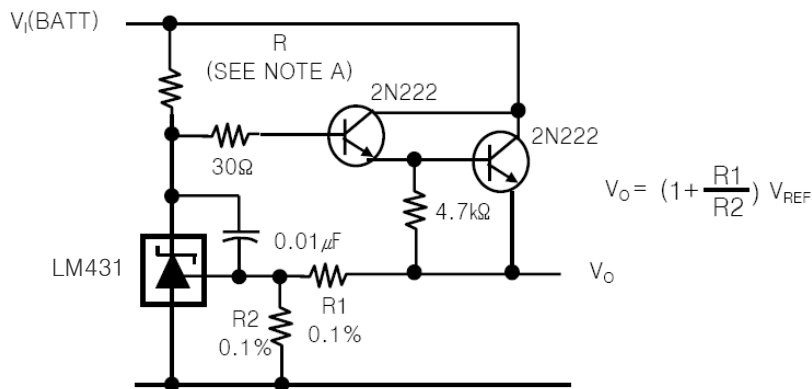

Note A : R Should provide cathode current $\geq 1\text{mA}$ to the LM431 at minimum $V_{I(BATT)}$

3. Output Control of a Three-Terminal Fixed Regulator

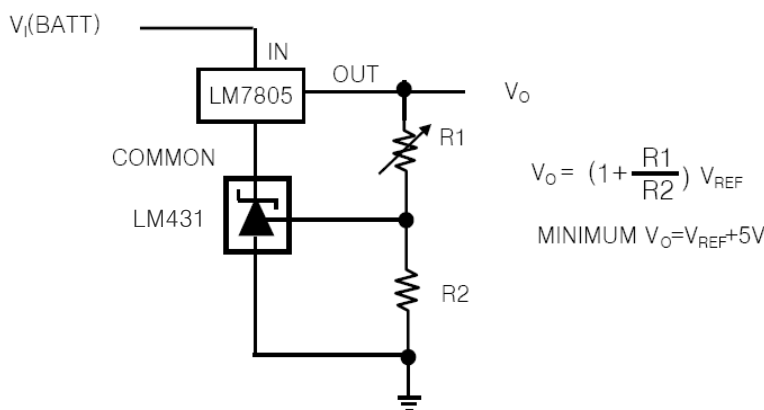

PROGRAMMABLE PRECISION SHUNT REGULATOR LM431/A/C

4. High-Current Shunt Regulator

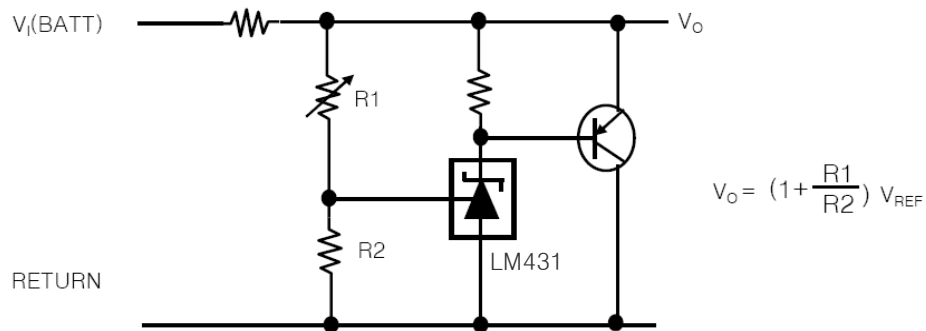

5. Precision 5V 1.5A Regulator

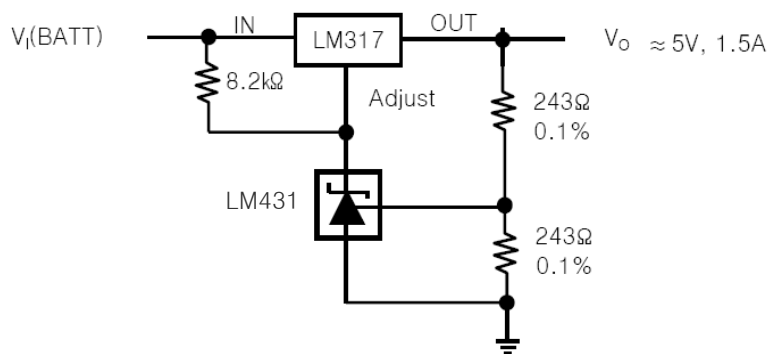

6. Efficient 5-V Precision Regulator

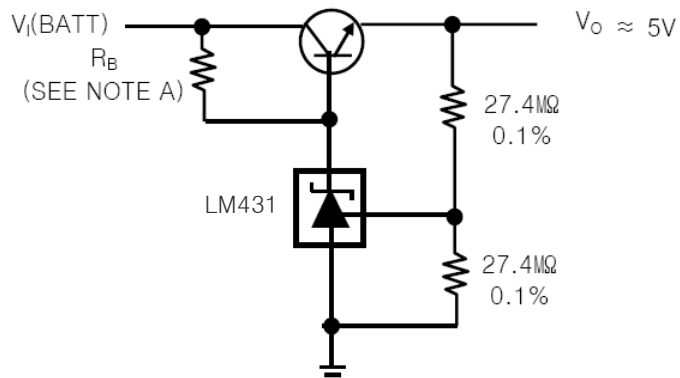

NOTE A : R_B Should provide cathode current $\geq 1\text{mA}$ to the LM431.

PROGRAMMABLE PRECISION SHUNT REGULATOR LM431/A/C

7. PWM Converter With Reference

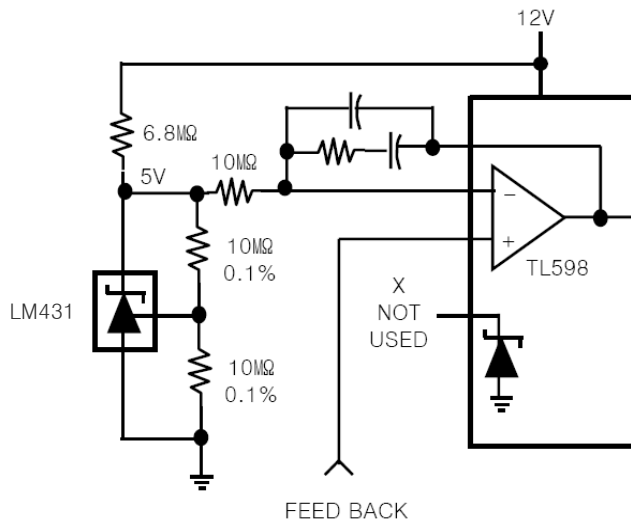

8. Voltage Monitor

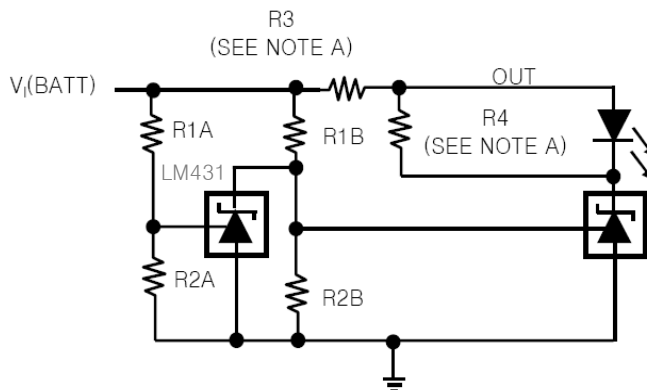

$$\text{LOW LIMIT} = \left(1 + \frac{R1B}{R2B}\right) V_{REF}$$

$$\text{HIGH LIMIT} = \left(1 + \frac{R1A}{R2A}\right) V_{REF}$$

LED ON WHEN LOW LIMIT < $V_{i(BATT)}$ < HIGH LIMIT

NOTE A : R3 and R4 are selected to provide the desired LED intensity and cathode current $\geq 1\text{mA}$ to the LM431 at the available $V_{i(BATT)}$.

9. Delay Timer

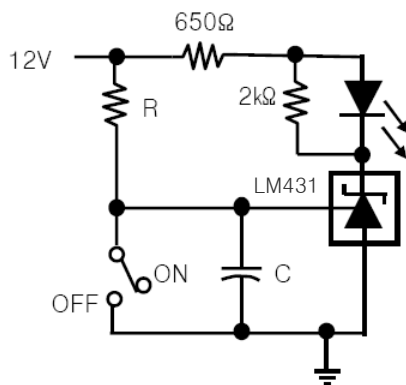

$$\text{DELAY} = R \times C \times I_N \left(\frac{12V}{12V - V_{REF}} \right)$$

PROGRAMMABLE PRECISION SHUNT REGULATOR LM431/A/C

10. Precision Current Limiter

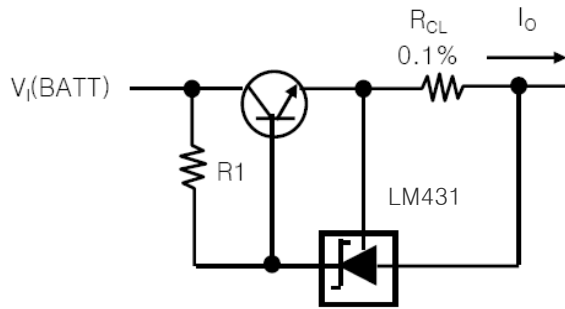

$$I_{OUT} = \frac{V_{REF}}{R_{CL}} + I_{KA}$$

$$R1 = \frac{V_{I(BATT)}}{\frac{I_o}{H_{FE}} + I_{KA}}$$

11. Precision Constant-Current Sink

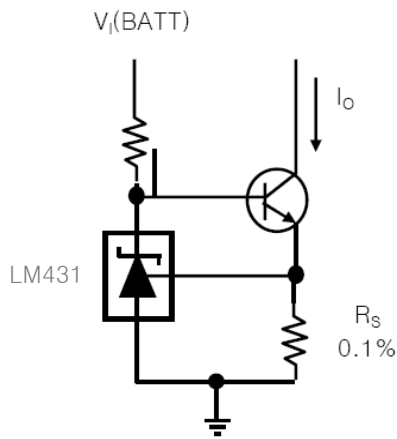

$$I_o = \frac{V_{REF}}{R_S}$$

PROGRAMMABLE PRECISION SHUNT REGULATOR LM431/A/C

REVISION NOTICE

The description in this data sheet can be revised without any notice to describe its electrical characteristics properly.