

FEATURES

- Programmable Output Voltage to 36V
- Extended Cathode Current Range 80uA to 100mA
- Low(Typ. 0.08Ω) Dynamic Output Impedance
- Adjustable Output Voltage
- Fast Turn-on Response
- Low Output Noise
- Excellent Temperature Coefficient 25ppm/°C
- Moisture Sensitivity Level 3

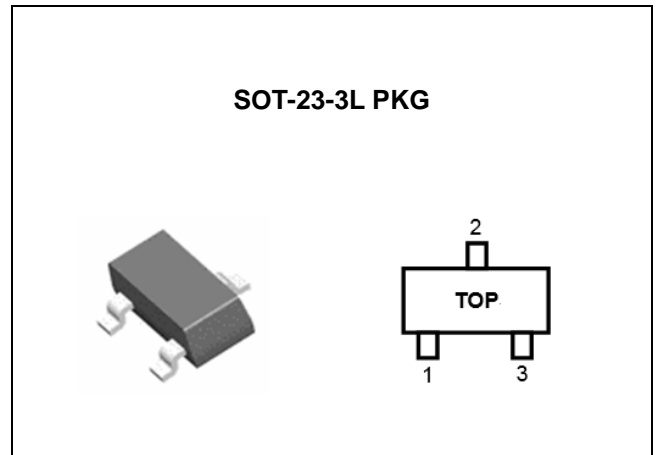

APPLICATION

- Secondary Side Regulation in Flyback SMPS
- Industrial, Computing, Consumer and Portables
- Adjustable Voltage and Current Referencing
- Power Management
- Power Isolation
- Zener Replacement

ORDERING INFORMATION

Device	Package
LPR431GXSF	SOT-23-3L

* Refer to the page 2 for detailed ordering Information.

DESCRIPTION

The LPR431 is a three-terminal adjustable shunt regulator with a specified thermal stability. The output voltage may be set to any value between V_{REF} and 36V with two external resistors. The active output circuitry provides a very sharp turn-on characteristic making these devices an excellent replacement for Zener diodes in many applications, such as on board regulation, adjustable power supplies, and switching power supplies.

ABSOLUTE MAXIMUM RATINGS

(Full operating ambient temperature range applies unless otherwise noted.)

CHARACTERISTIC	SYMBOL	MIN.	MAX.	UNIT
Cathode Voltage	V_{KA}	-	40	V
Cathode Current Range	I_{KA}	-	150	mA
Reference Input Current Range	I_{REF}	-	10	mA
Junction Temperature Range	T_J	-40	150	°C
Operating Temperature Range	T_{OPR}	-40	125	°C
Storage Temperature Range	T_{STG}	-65	150	°C

RECOMMENDED OPERATING CONDITIONS

CHARACTERISTIC	SYMBOL	MIN.	MAX.	UNIT
Cathode Voltage	V_{KA}	V_{REF}	36	V
Cathode Current	I_{KA}	0.08	100	mA
Operating Temperature range	T_A	-40	85	°C

ORDERING INFORMATION

VREF	Package	Tolerance	Order No.	Supplied As	Status
2.5V	SOT-23-3L	0.5%	LPR431GCSF	Reel	Active
		1%	LPR431GASF	Reel	Active

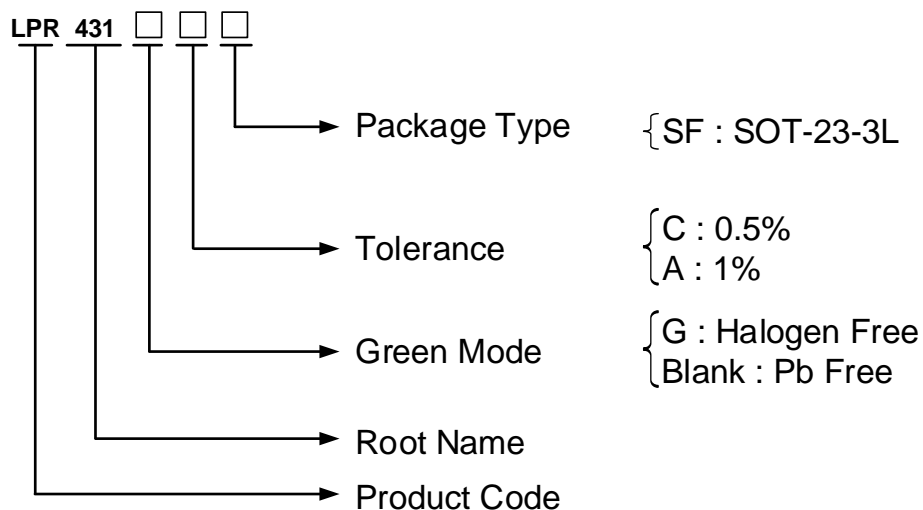

PIN CONFIGURATION

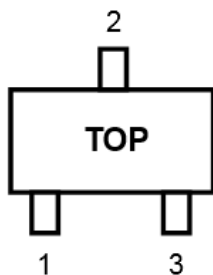

SOT-23-3L PKG

PIN DESCRIPTION

Pin No.	SOT-23-3L PKG	
	Name	Function
1	Cathode	Input Supply Voltage
2	Anode	Ground
3	Reference	Reference Voltage

ELECTRICAL CHARACTERISTICS

($T_A=25\text{ }^\circ\text{C}$, unless otherwise specified)

CHARACTERISTIC	SYMBOL	TEST CONDITION	MIN.	TYP.	MAX.	UNIT	
Reference Input Voltage	V_{REF}	$V_{KA}=V_{REF}$, $I_K=1\text{mA}$	LPR431GC	2.487	2.500	2.512	V
			LP4R31GA	2.475	2.500	2.525	
Deviation of Reference Input Voltage (Note 1)	$\Delta V_{REF}/\Delta T_A$	$V_{KA}=V_{REF}$, $I_K=1\text{mA}$, $T_A = \text{Full range}$	-	25	34	mV	
Ratio of Change in Reference Input Voltage to the Change in Cathode Voltage	$\Delta V_{REF}/\Delta V_{KA}$	$I_K=1\text{mA}$	$\Delta V_{KA}=10\text{V to } V_{REF}$	-2.7	-1.0	-	mV/V
			$\Delta V_{KA}=36\text{V to } 10\text{V}$	-2.0	-0.4	-	
Reference Input Current	I_{REF}	$I_K=1\text{mA}$, $R_1=10\text{k}\Omega$, $R_2=\infty$	-	180	500	nA	
Deviation of Reference Input Current (Note 1)	$\Delta I_{REF}/\Delta T_A$	$I_K=1\text{mA}$, $R_1=10\text{k}\Omega$, $R_2=\infty$, $T_A=\text{Full range}$	-	100	300	nA	
Minimum Cathode Current for Regulation	$I_{K(\text{MIN})}$	$V_{KA} = V_{REF}$	-	30	80	μA	
Off-State Cathode Current	$I_{K(\text{OFF})}$	$V_{KA}=36\text{V}$, $V_{REF}=0$	-	0.01	1	μA	
Dynamic Impedance (Note 2)	$ Z_{KA} $	$V_{KA}=V_{REF}$, $I_K=0.2\text{mA}\sim 100\text{mA}$, $f \leq 1\text{kHz}$		0.08	0.3	Ω	

TEST CIRCUITS

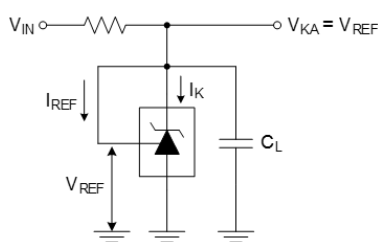

< Fig 1. Test circuit for $V_{KA} = V_{REF}$ >

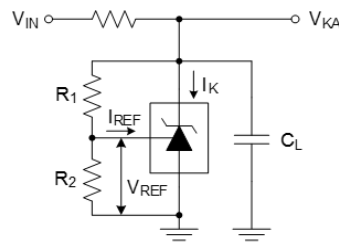
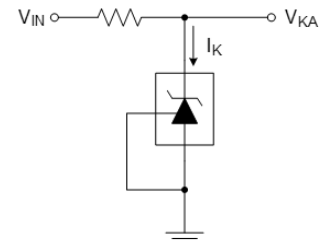

Fig 2. Test circuit for $V_{KA} \geq V_{REF}$ >



< Fig 3. Test circuit for $I_{K(\text{OFF})}$ >

(Note 1) The deviation parameters $\Delta V_{REF}/\Delta T_A$ and $\Delta I_{REF}/\Delta T_A$ are defined as the differences between the maximum and minimum values obtained over the recommended temperature range. The average full-range temperature coefficient of the reference voltage, αV_{REF} , is defined as :

$$|\alpha V_{REF}|(\text{ppm}/^\circ\text{C}) = \frac{\left(\frac{V_{I(\text{dev})}}{V_{REF \text{ at } 25^\circ\text{C}}}\right) \times 10^6}{\Delta T_A}$$

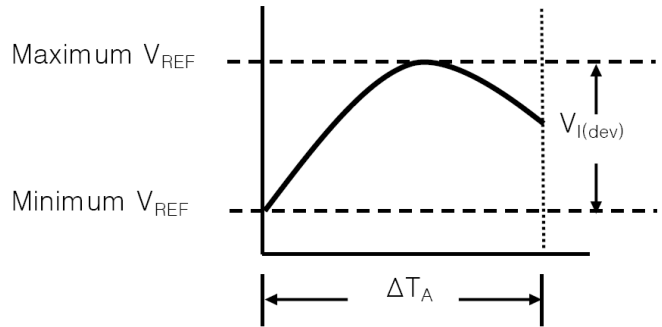

Where :

ΔT_A is the recommended operating free-air temperature range of the device.

αV_{REF} can be positive or negative, depending on whether minimum V_{REF} or maximum V_{REF} , respectively, occurs at the lower temperature.

(Note 2) The dynamic impedance is defined as : $|Z_{KA}| = \frac{\Delta V_{KA}}{\Delta I_{KA}}$

When the device is operating with two external resistors, the total dynamic impedance of the circuit is

given by: $|Z'| = \frac{\Delta V}{\Delta I} \approx |Z_{KA}| (1 + R1/R2)$

TYPICAL APPLICATION

1. Shunt Regulator

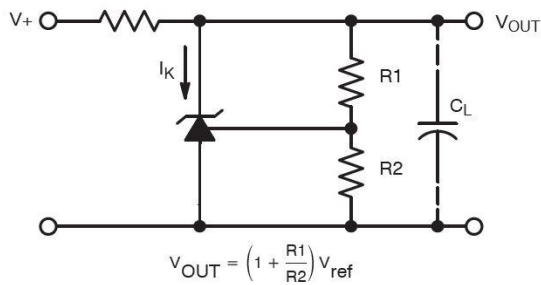

2. High Current Shunt Regulator

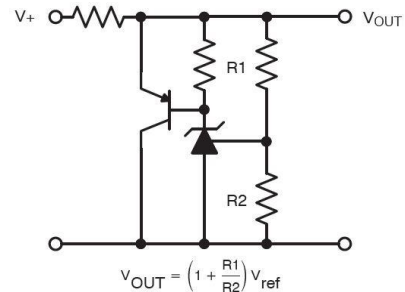

3. Output Control for a Three-Terminal Fixed Regulator

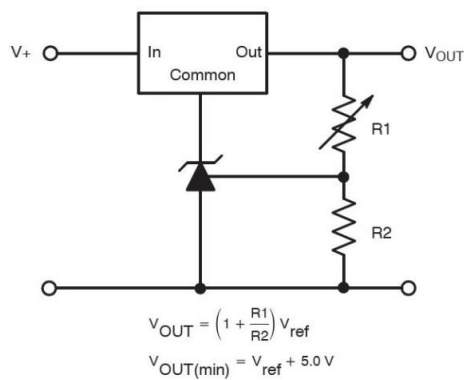

4. Series Pass Regulator

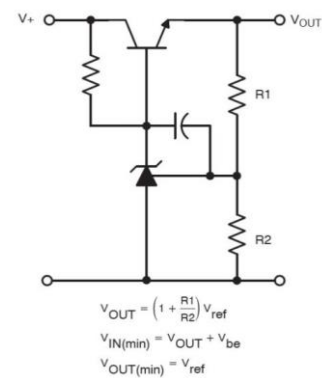

5. Constant Current Source

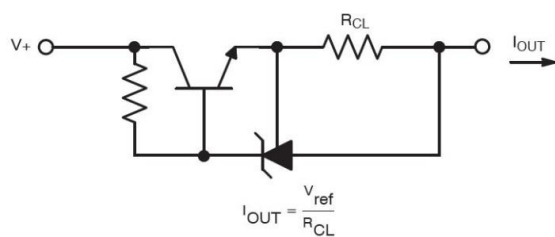

6. Constant Current Sink

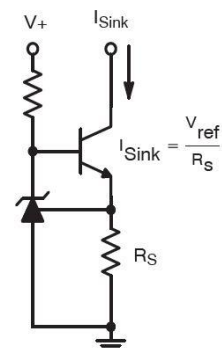

REVISION NOTICE

The description in this datasheet can be revised without any notice to describe its electrical characteristics properly.