



ONE CELL LITHIUM-ION / POLYMER BATTERY PROTECTION IC

DESCRIPTION

UTC **UB2421** is a lithium-ion / lithium-polymer rechargeable battery protection IC incorporating high accuracy voltage detection circuits and delay circuits.

It is suitable for protection of single cell lithium-ion / lithium polymer battery packs from overcharge, over discharge and over current.

The tiny package required external few components make the UTC **UB2421** be able to be applied to space limited battery pack.

FEATURES

- * Wide supply voltage range: $V_{DD}=1.8V\sim 9.0V$
- * Ultra-low quiescent Current: $I_{DD}=3.0\mu A$ ($V_{DD}=3.9V$)
- * Ultra-low power-down Current: $I_{PD}=0.1\mu A$ ($V_{DD}=2.0V$)
- * Overcharge detection voltage: $V_{OCU}=4.30V\pm 0.05V$
- * Overcharge release voltage: $V_{OCR}=4.10V\pm 0.05V$
- * Overdischarge release voltage: $V_{ODL}=2.40V\pm 0.10V$
- * Overdischarge release voltage: $V_{ODR}=3.00V\pm 0.10V$
- * Over current detection voltage: $V_{OI1}=0.15V\pm 0.03V$
- * Short circuit detection voltage: $V_{OI2}=1.35V$ (Fixed)
- * Charger detection voltage: $V_{CH}=-0.7V$
- * Delay times are generated by an internal circuit.
(External capacitors are unnecessary.)

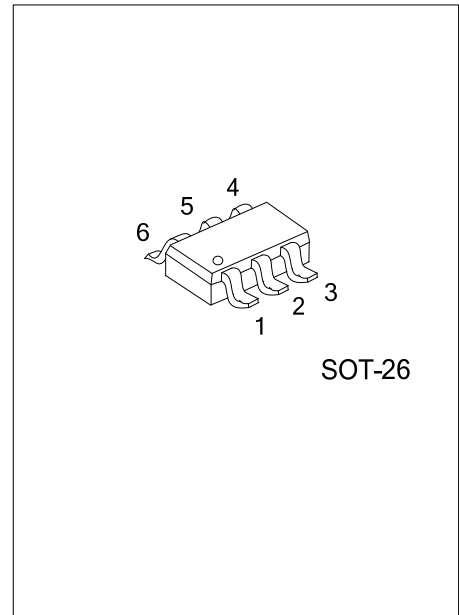

ORDERING INFORMATION

Ordering Number	Package	Packing
UB2421G-AG6-R	SOT-26	Tape Reel

<p>UB2421G-AG6-R</p> <p>(1) Packing Type</p> <p>(2) Package Type</p> <p>(3) Halogen Free</p>	<p>(1) R: Tape Reel</p> <p>(2) AG6: SOT-26</p> <p>(3) G: Halogen Free</p>
--	---

MARKING

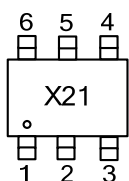

■ PIN CONFIGURATION

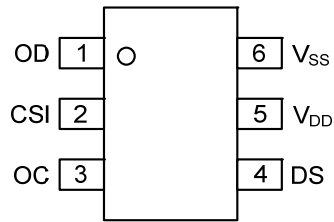

■ PIN DESCRIPTION

PIN NO.	PIN NAME	DESCRIPTION
1	OD	MOSFET gate connection pin for discharge control
2	CSI	Input pin for current sense, charger detection
3	OC	MOSFET gate connection pin for charge control
4	DS	Test pin for reduce delay time
5	V _{DD}	Positive power input pin
6	V _{SS}	Negative power input pin

■ SERIAL CODE LIST

Model	Package	Overcharge Detection Voltage [V _{OCU}](V)	Overcharge Release Voltage [V _{OCR}](V)	Overdischarge Detection Voltage [V _{ODL}](V)	Overdischarge Release Voltage [V _{ODR}](V)	Over Current Detection Voltage [V _{O11}](V)
UB2421	SOT-26	4.300±0.050	4.100±0.05	2.40±0.100	3.00±0.100	0.15±0.03

■ BLOCK DIAGRAM

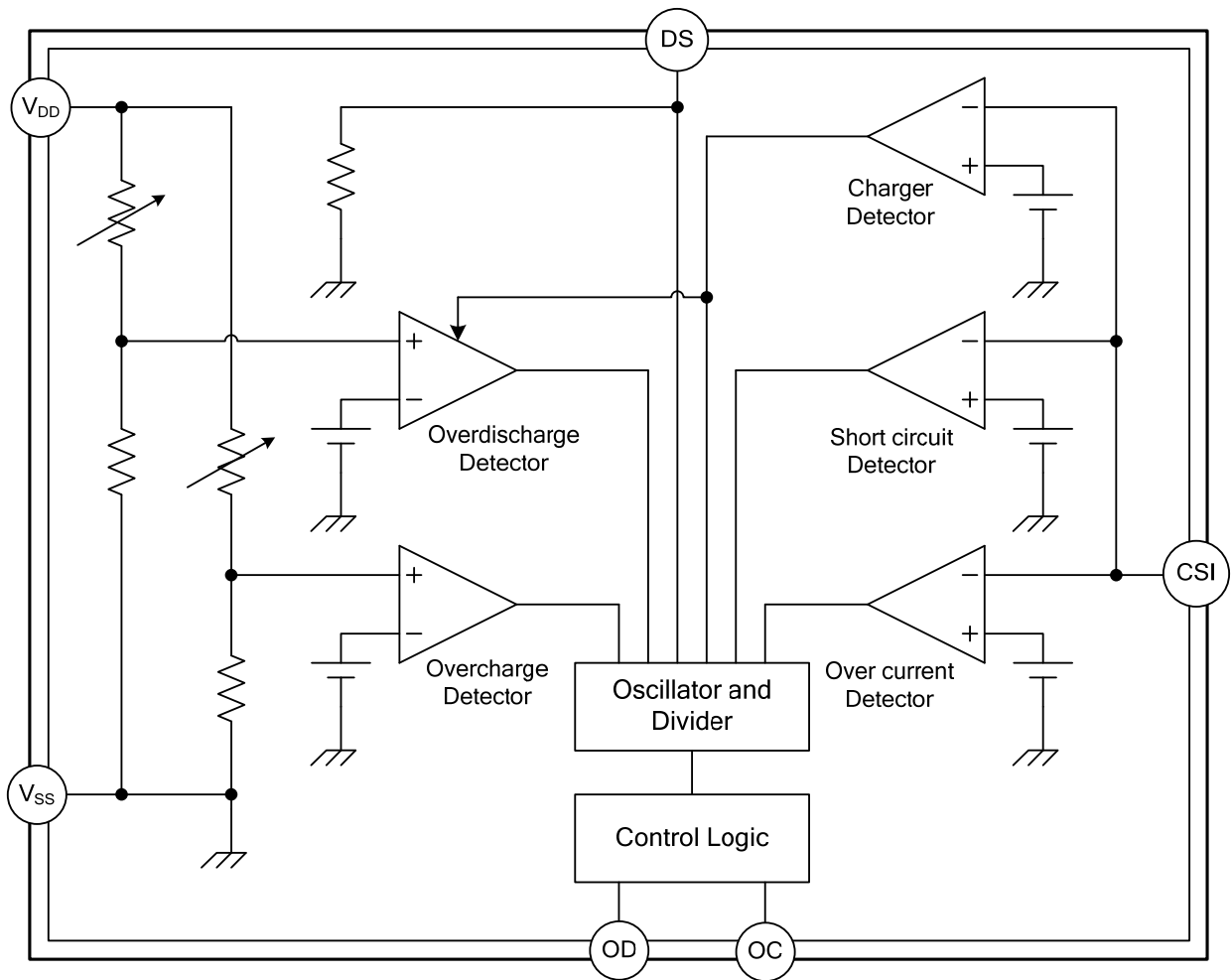

■ ABSOLUTE MAXIMUM RATING ($V_{SS}=0V$, $T_a=25^{\circ}C$, unless otherwise specified)

PARAMETER	SYMBOL	RATINGS	UNIT
Input Voltage Between V_{DD} And V_{SS}	V_{DD}	$V_{SS}-0.3\sim V_{SS}+12$	V
OC Output Pin Voltage	V_{OC}	$V_{DD}-15\sim V_{DD}+0.3$	V
OD Output Pin Voltage	V_{OD}	$V_{SS}-0.3\sim V_{DD}+0.3$	V
CSI Input Pin Voltage	V_{CSI}	$V_{DD}-15\sim V_{DD}+0.3$	V
Operating Temperature	T_{OPR}	$-40\sim+85$	$^{\circ}C$
Storage Temperature	T_{STG}	$-40\sim+125$	$^{\circ}C$

Note: Absolute maximum ratings are those values beyond which the device could be permanently damaged.

Absolute maximum ratings are stress ratings only and functional device operation is not implied.

■ ELECTRICAL CHARACTERISTICS ($T_a=25^{\circ}C$, unless otherwise specified)

PARAMETER	SYMBOL	TEST CONDITIONS	MIN	TYP	MAX	UNIT
CURRENT CONSUMPTION						
Supply Current	I_{DD}	$V_{DD}=3.9V$		3.0	6.0	μA
Power-Down Current	I_{PD}	$V_{DD}=2.0V$			0.1	μA
OPERATING VOLTAGE						
Operating Input Voltage	V_{DS}	$V_{DD}-V_{SS}$	1.8		9.0	V
DETECTION VOLTAGE						
Overcharge Voltage	Detection	V_{OCU}	4.25	4.30	4.35	V
	Release	V_{OCR}	4.05	4.10	4.15	V
Overdischarge Voltage	Detection	V_{ODL}	2.30	2.40	2.50	V
	Release	V_{ODR}	2.90	3.00	3.10	V
Over Current Detection Voltage	V_{OI1}		0.12	0.15	0.18	V
Short Circuit Detection Voltage	V_{OI2}	$V_{DD}=3.0V$	1.0	1.35	1.75	V
Charger Detection Voltage	V_{CH}		-1.2	-0.7	-0.2	V
DELAY TIME						
Overcharge Detection Delay Time	T_{OC}	$V_{DD}=3.6V$ to $4.5V$, $DS=$ Floating		80	200	ms
		$V_{DD}=3.6V$ to $4.5V$, $V_{DS}=V_{DD}$		5	15	ms
Overdischarge Detection Delay Time.	T_{OD}	$V_{DD}=3.6V$ to $2.0V$, $DS=$ Floating		40	100	ms
		$V_{DD}=3.6V$ to $2.0V$, $V_{DS}=V_{DD}$		2.5	8.5	ms
Over Current Detection Delay Time	T_{OI1}	$V_{DD}=3.6V$		10	20	ms
Short Circuit Detection Delay Time	T_{OI2}	$V_{DD}=3.6V$		10	50	μs
OTHER ITEMS						
OC Pin Output Voltage	High	V_{OH1}		$V_{DD}-0.1$	$V_{DD}-0.02$	V
	Low	V_{OL1}		0.1	0.5	V
OD Pin Output Voltage	High	V_{OH2}		$V_{DD}-0.1$	$V_{DD}-0.02$	V
	Low	V_{OL2}		0.1	0.5	V

■ TYPICAL APPLICATION CIRCUIT

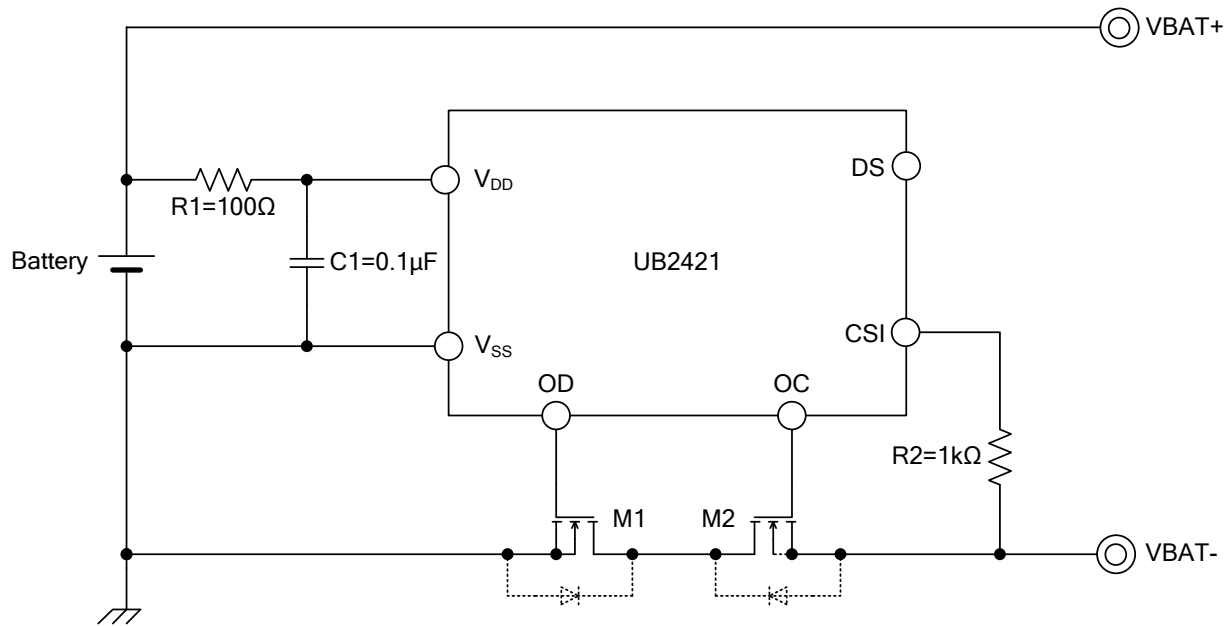

■ DESCRIPTION OF OPERATION

1. Normal Condition

The **UB2421** monitors the voltage of the battery connected between V_{DD} and V_{SS} . The charge and discharge scheme will be sensed by the voltage difference between V_{CSI} and V_{SS} .

When $V_{ODL} < V_{DD} < V_{OCU}$ and $V_{CH} < V_{CSI} < V_{O11}$, **UB2421** will turn on the charging (M2) and discharging (M1) control MOSFETs. The charging and discharging processes can be operated normally.

2. Overcharge Condition

When the battery voltage becomes higher than the overcharge detection voltage (V_{OCU}) during normal charging condition through a delay time longer than TOC (the overcharge detection delay time), **UB2421** will turn M2 off to stop charging.

3. Release of Overcharge Condition

(1) When the battery is self discharging, and if $V_{DD} < V_{OCR}$ and $V_{O11} > V_{CSI} > V_{CH}$ occurs, M2 will be turned on and back to normal condition.

(2) Remove the charger and connect **UB2421** to a load. The discharging current will flow through the parasitic diode of M2. At this moment, V_{CSI} increases a voltage (VF) of the parasitic diode from the V_{SS} level momentarily. While $V_{CSI} > V_{O11}$ and $V_{DD} < V_{OCU}$ occur, M2 will be turns on and back to normal condition.

4. Over discharge Condition

When the battery voltage falls below the overdischarge detection voltage (V_{ODL}) during discharging condition and through a delay time longer than TOD (the overdischarge detection delay time), **UB2421** will turn M1 off to stop discharging. In the meanwhile, CSI will be pulled up to V_{DD} through an internal resistance.

If $V_{CSI} > V_{O12}$, **UB2421** will enter into power-down mode. While in this mode, the current consumption is lower than 0.1 μ A.

5. Release of Power-down mode

After entering power-down mode, when the system is connected to a charger, the charging current will flow through the parasitic diode of M1. If $V_{CSI} < V_{O12}$ occurs, then **UB2421** will release power-down mode. While keeping charging status, there are two ways back to normal condition:

(1) If $V_{CSI} < V_{CH}$ (Charger detection), then when $V_{DD} > V_{ODL}$, M1 will be turned on and system will back to normal condition.

(2) If $V_{CH} < V_{CSI} < V_{O12}$, the condition $V_{DD} > V_{ODR}$, must be satisfied for M1 to be turned on, and then the system will back to the normal condition.

6. Charger Detection

While connecting to a charger after entering into power-down mode, then if $V_{DD} < V_{CH}$, M1 will be turned on when $V_{DD} > V_{ODL}$. The system will back to normal condition since the charger has been detected.

7. Abnormal Charge Current Condition

When a charger is connected to the battery system in normal condition, then if $V_{DD} < V_{OCU}$ and $V_{CSI} < V_{CH}$ occur through a delay time than TOC (delay time of overcharge detection), M2 will be turned off to stop this charging status, which is abnormal charge current condition.

Abnormal charge current condition is released when the voltage of CSI pin becomes higher than charger detection voltage (V_{CH}), or the charger is removed.

8. Over Current (or Short Circuit) Condition

When the current is too large during discharging under normal condition as a result of the voltage detected by CSI is greater than V_{O11} (or V_{O12}) through a delay time T_{O11} (or T_{O12}), it satisfies the over current (or short circuit) condition. Then M1 will be turned off and CSI will be pulled down to V_{SS} through an internal resistance. It is called the over current (or short circuit) condition.

(1) If the over current (or short circuit) is detected and it keeps longer than the overdischarge detection delay time with the same circumstance, the condition will be changed to the power-down mode when the battery voltage falls below the overdischarge detection voltage.

(2) If the battery voltage falls below the overdischarge detection voltage (V_{ODL}) due to the over current (or short circuit), the discharging control M1 will be turned off when this condition occurs. After overdischarge detection delay time (T_{OD}) expired, if the battery voltage is still equal to or lower than the overdischarge detection voltage, the condition will be changed to power-down mode.

■ DESCRIPTION OF OPERATION(Cont.)

9. Release of Over Current (or Short Circuit) Condition

While the protection IC remains in the Over current (or Short circuit) condition, then if the load is removed or the impedance between V_{BAT+} and V_{BAT-} is larger than $500k\Omega$ as well as $V_{CSI} < V_{OI1}$, M1 will be turned on and the back to normal condition.

10. DS Pin

By forcing DS to V_{DD} , the delay time of the overcharge and overdischarge can be reduced to within 50ms; therefore, testing time of protector circuit board can be reduced. $1.6M\Omega$ pull down resistor is connected between DS pin and V_{SS} internally. DS pin should be open or connected to V_{SS} in the actual application.

■ TIMING DIAGRAM

1. Overcharge Condition → Load Discharge → Normal Condition

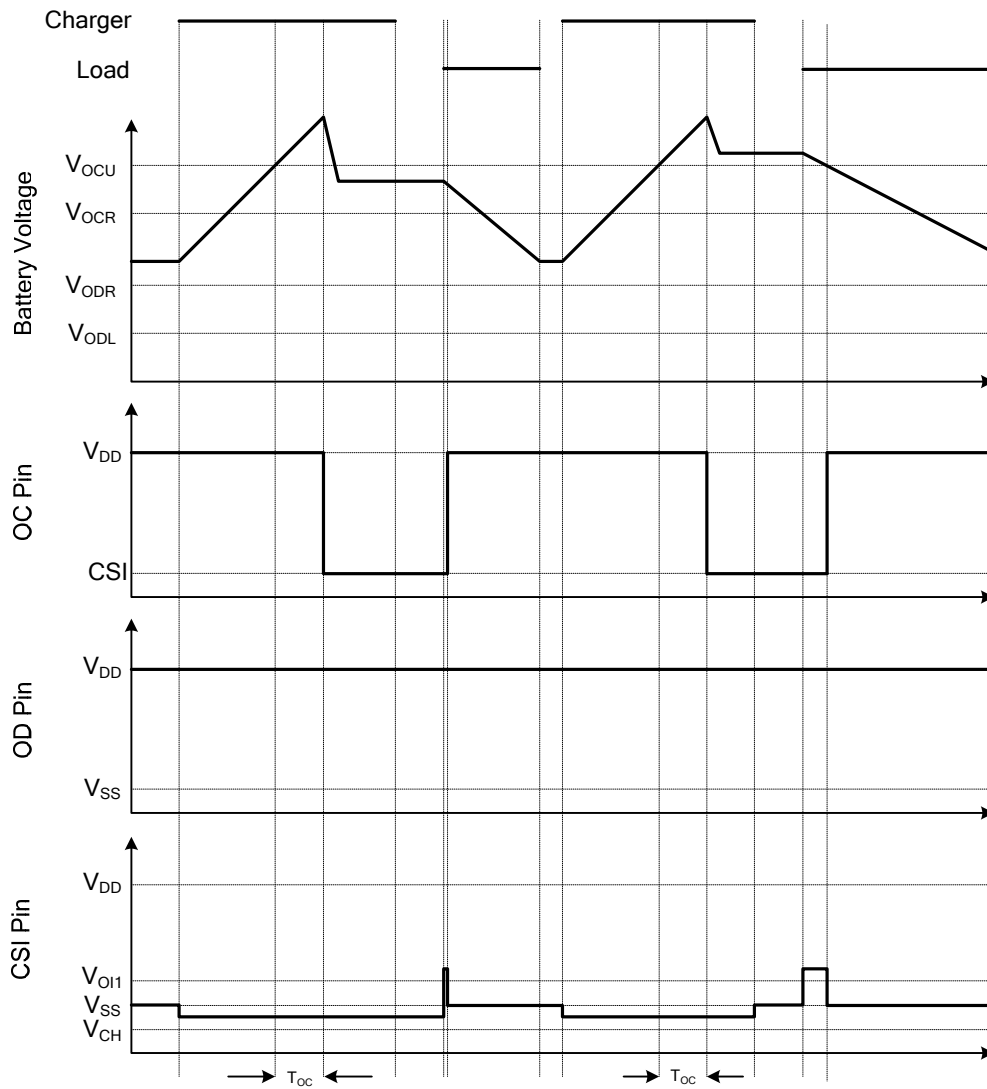

■ TIMING DIAGRAM(Cont.)

2. Overdischarge Condition → Charging By a Charger → Normal Condition

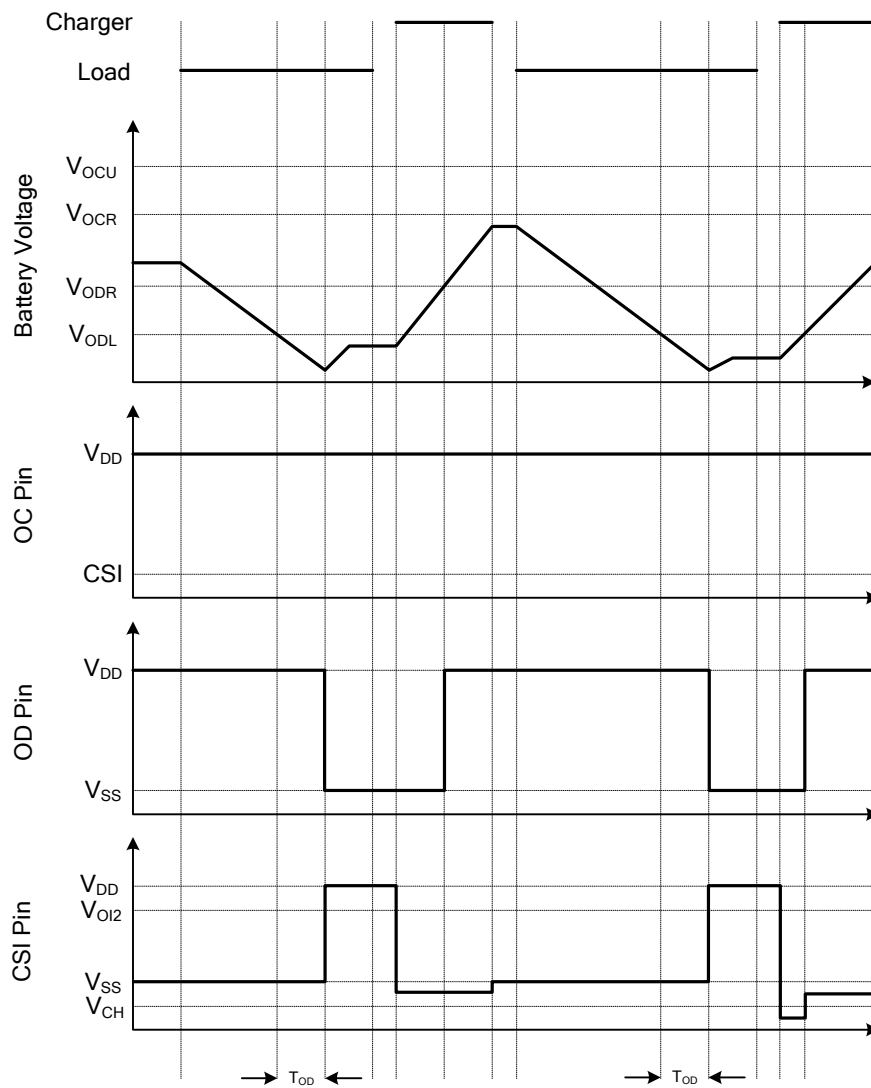

■ TIMING DIAGRAM(Cont.)

3. Overdischarge Condition → Abnormal Charger Current Condition → Normal Condition

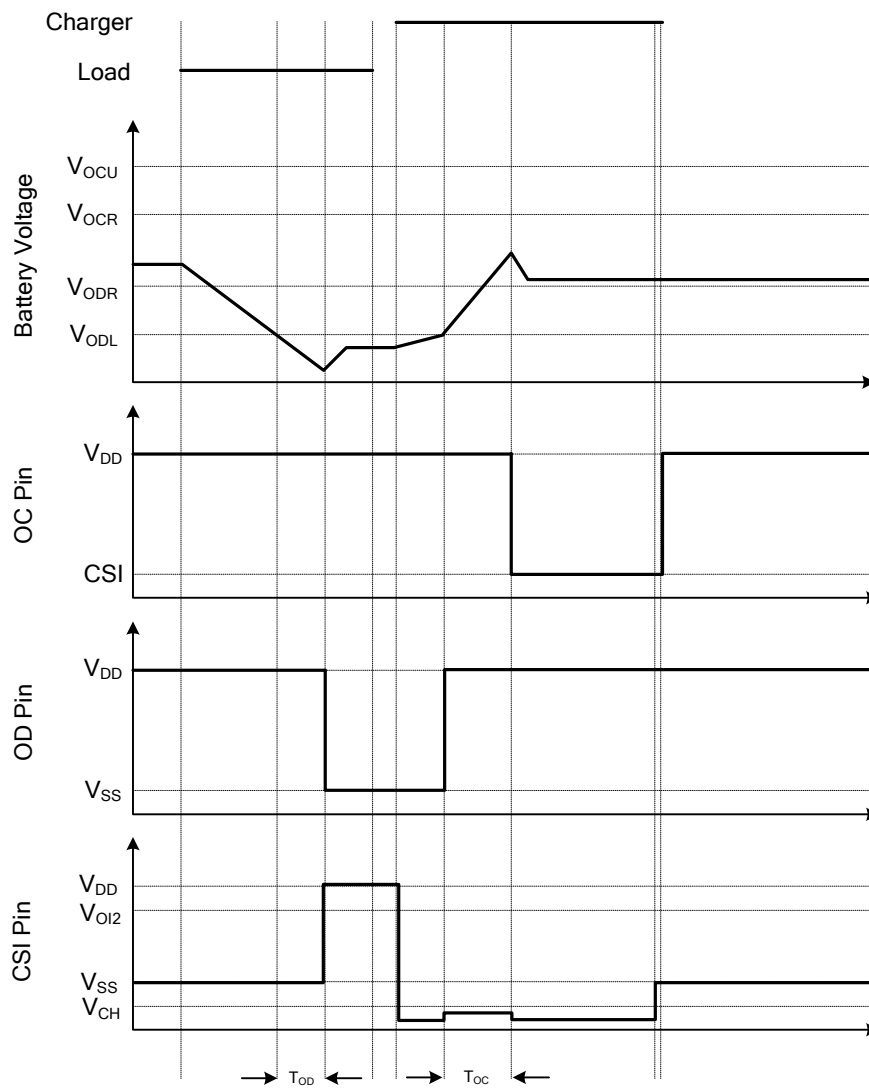

■ TIMING DIAGRAM(Cont.)

4. Over Current and Short Circuit Condition → Normal Condition

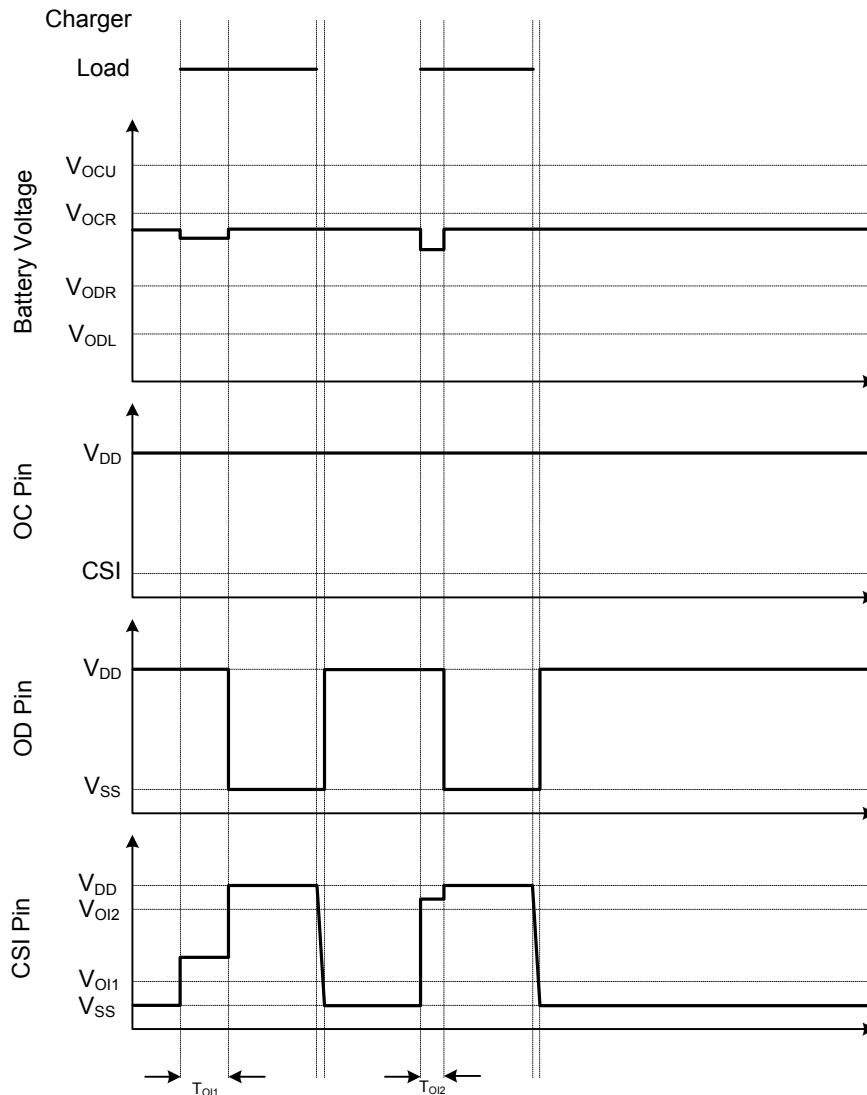

UTC assumes no responsibility for equipment failures that result from using products at values that exceed, even momentarily, rated values (such as maximum ratings, operating condition ranges, or other parameters) listed in products specifications of any and all UTC products described or contained herein. UTC products are not designed for use in life support appliances, devices or systems where malfunction of these products can be reasonably expected to result in personal injury. Reproduction in whole or in part is prohibited without the prior written consent of the copyright owner. The information presented in this document does not form part of any quotation or contract, is believed to be accurate and reliable and may be changed without notice.