



UB3846

LINEAR INTEGRATED CIRCUIT

**LOW COST POWER-SAVING
MODE PWM CONTROLLER
FOR FLYBACK CONVERTERS**

■ DESCRIPTION

The UTC **UB3846** is a high performance current mode PWM controller ideally suited for low standby power and cost effective off-line flyback converter.

Low V_{DD} startup current make the power reliable in startup design and a large value resistor could be used in the startup circuit to minimize the standby power. At no load condition, the IC operates in burst mode for lower standby power and in decreasing frequency for higher conversion efficiency at light load condition. The PWM switching frequency is programmable externally at normal operation.

The UTC **UB3846** contains protection coverage with automatic self-recovery including OCP (cycle-by-cycle current limiting), OTP (over temperature protection), UVLO (V_{DD} over voltage clamp and under voltage lockout). To protect the power MOSFET, Gate-drive output is fixed up to 15V max.

The internal slope compensation improves system stability at high PWM duty cycle output. Leading-edge blanking on current sense (CS) input removes the signal glitch that offers minimal requirement of external component and lower system cost.

Excellent EMI performance is achieved by UTC proprietary frequency hopping technique together with soft driver control. Audio noise is eliminated because switch frequency is more than 20kHz during operation.

The UTC **UC3846** can be used in the applications, such as battery charger, power adaptor, set-top box power supplies, ink jet printers open-frame SMPS

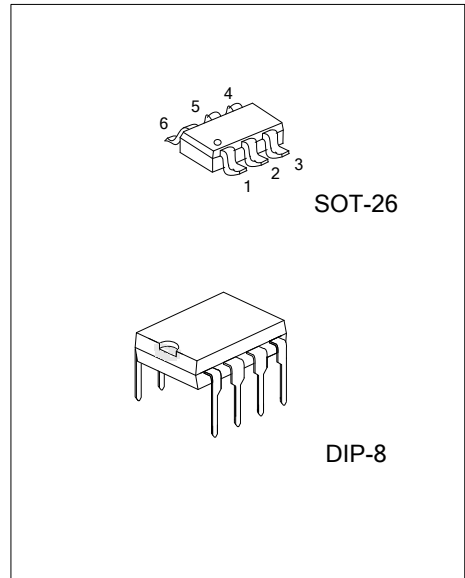

■ FEATURES

- * UTC proprietary frequency hopping technology for Improved EMI
- * Performance.
- * Power-saving mode for high light-load efficiency
- * Burst mode for minimum standby power
- * Dynamic peak current limiting for constant output power
- * Built-in synchronized slope compensation
- * OTP, OVP and V_{DD} clamp for higher security
- * Programmable PWM Frequency
- * Gate output voltage clamped at 15V
- * Low start-up current
- * Cycle-by-cycle Current Limiting
- * Under voltage lockout (UVLO)
- * Few external components required

■ ORDERING INFORMATION

Ordering Number		Package	Packing
Lead Free	Halogen Free		
UB3846L-AG6-R	UB3846G-AG6-R	SOT-26	Tape Reel
UB3846L-D08-T	UB3846G-D08-T	DIP-8	Tube

<p>UB3846L-AG6-R</p> <p>(1) Packing Type</p> <p>(2) Package Type</p> <p>(3) Lead Free</p>	<p>(1) T: Tube, R: Tape Reel</p> <p>(2) AG6: SOT-26, D08: DIP-8</p> <p>(3) G: Halogen Free, L: Lead Free</p>
---	--

■ PIN CONFIGURATION

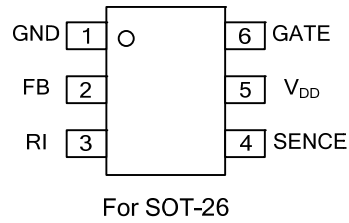
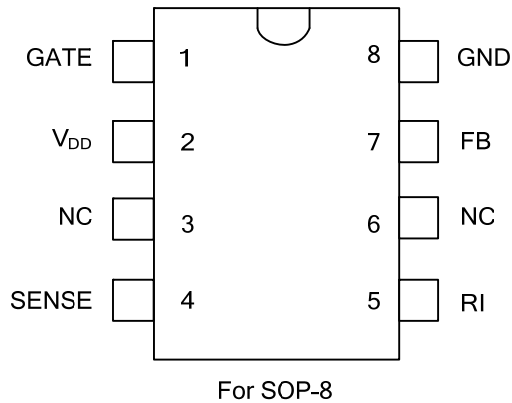

■ PIN DESCRIPTION

PIN NO.	PIN NAME	PIN TYPE	DESCRIPTION
1	GATE	O	The totem-pole output driver for driving the power MOSFET.
2	V _{DD}	P	Power supply.
3	NC		NC pin.
4	SENSE	I	Current sense input pin. Connected to MOSFET current sensing resistor node.
5	RI	I	A resistor connected between RI and GND sets switching frequency. A 100kΩ resistor R _i results in a 70kHz switching frequency.
6	NC		NC pin.
7	FB	I	Feedback input pin. The PWM duty cycle is determined by voltage level into this pin and SENSE pin input.
8	GND	P	Ground.

■ BLOCK DIAGRAM

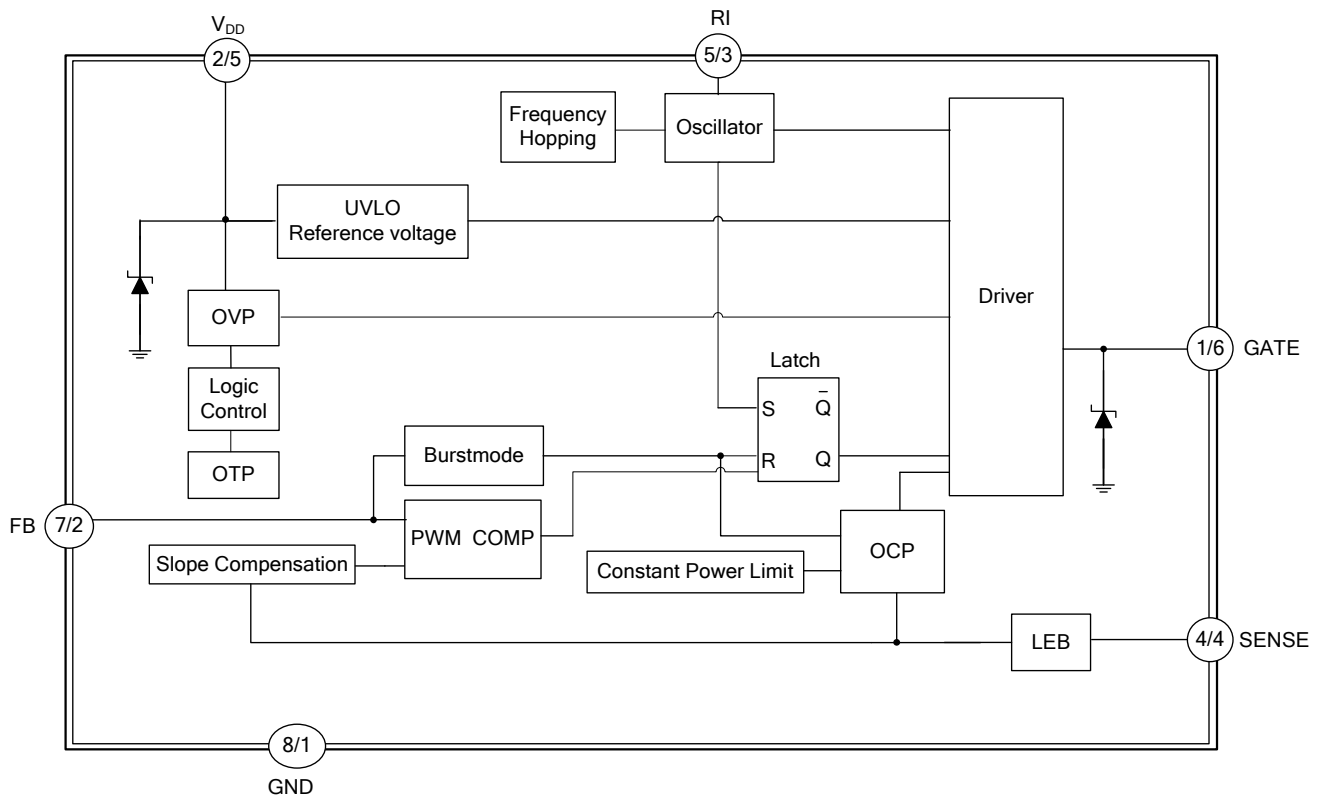

■ ABSOLUTE MAXIMUM RATINGS ($T_A=25^{\circ}\text{C}$, $V_{DD}=15\text{V}$, unless otherwise specified)

PARAMETER	SYMBOL	RATINGS	UNIT
Supply Voltage	V_{DD}	25	V
Zener Clamp		28	V
Zener Current		10	mA
Input Voltage to FB Pin	V_{FB}	7	V
Input Voltage to CS Pin	V_{SENSE}	7	V
Junction Temperature	T_J	+150	$^{\circ}\text{C}$
Operating Temperature	T_{OPR}	-40 ~ +125	$^{\circ}\text{C}$
Storage Temperature	T_{STG}	-50 ~ +150	$^{\circ}\text{C}$

Note: Absolute maximum ratings are those values beyond which the device could be permanently damaged.

Absolute maximum ratings are stress ratings only and functional device operation is not implied.

■ OPERATING RANGE

PARAMETER	SYMBOL	RATINGS	UNIT
Supply Voltage	V_{DD}	8.2 ~ 21	V

■ ELECTRICAL CHARACTERISTICS ($T_A=25^{\circ}\text{C}$, $V_{DD}=15\text{V}$, $R_I=100\text{k}\Omega$, unless otherwise specified)

PARAMETER	SYMBOL	TEST CONDITIONS	MIN	TYP	MAX	UNIT	
SUPPLY SECTION							
Start Up Current	I_{STR}	$V_{DD} = V_{DD(ON)} - 0.1\text{V}$		22	45	μA	
IC Operating current	I_{OP}	FB PIN OPEN		7	9	mA	
UNDER-VOLTAGE LOCKOUT SECTION							
Start Threshold Voltage	$V_{THD(ON)}$		13.5	14.2	15	V	
Min. Operating Voltage	$V_{DD(MIN)}$		7.5	8.2	9	V	
Hysteresis	$V_{DD(HY)}$			6		V	
INTERNAL VOLTAGE REFERENCE							
Reference Voltage	V_{REF}	measured at pin V_{FB}	6.3	6.5	6.7	V	
CONTROL SECTION							
V_{FB} Operating Level	V_{MIN}		0.5			V	
	V_{MAX}				4.4	V	
Burst-Mode Out FB Voltage	$V_{FB(OUT)}$	$V_{SENSE} = 0$		1.7		V	
Reduce-Frequency end FB Voltage	$V_{FB(END)}$	$V_{SENSE} = 0$		1.6		V	
Burst-Mode Enter FB Voltage	$V_{FB(IN)}$	$V_{SENSE} = 0$		1.5		V	
Switch Frequency	Normal Power-Saving	$F_{(SW)}$	FB PIN OPEN	61	68	75	kHz
			Before enter burst mode	24		31	kHz
Duty Cycle		D_{MAX}	FB PIN OPEN, $V_{SENSE} = 0$	68	74	80	%
		D_{MIN}	$V_{FB} < 0.5\text{V}$	0			%
Frequency Hopping		$F_{J(SW)}$	± 1.5	± 3	± 4.5	kHz	
Frequency Variation VS V_{DD} Deviation		F_{DV}	$V_{DD} = 10$ to 20V			5	%
Frequency Variation VS Temperature Deviation		F_{DT}	$T = -40$ to 105°C			5	%
Feedback Resistor		R_{FB}	$V_{FB} = 0\text{V}$	16	21	26	k Ω
PROTECTION SECTION							
OVP threshold		V_{OVP}	FB PIN OPEN		28		V
OTP threshold		$T_{(THR)}$		120	135	150	$^{\circ}\text{C}$
CURRENT LIMITING SECTION							
Peak Current Limitation		V_{CS}	FB PIN OPEN		0.85	1	V
DRIVER OUTPUT SECTION							
Output Voltage Low State		V_{OL}	$I_{SOURCE} = 200\text{ mA}$			2.5	V
Output Voltage High State		V_{OH}	$I_{SINK} = 200\text{ mA}$	12.2			V
Output Voltage Rise Time		t_R	$C_L = 1.0\text{ nF}$		200	300	ns
Output Voltage Fall Time		t_F	$C_L = 1.0\text{ nF}$		50	90	ns

■ OPERATION DESCRIPTION

The UTC **UC3846** devices integrate many useful designs into one controller for low-power switch-mode power supplies. The following descriptions highlight some of the features of the UTC **UB3846** series.

Start-up Current

The start-up current is only 22 μ A. Low start-up current allows a start-up resistor with a high resistance and a low-wattage to supply the start-up power for the controller. For AC/DC adaptor with universal input range design, a 1 M Ω , 1/8 W startup resistor could be used together with a V_{DD} capacitor to provide a fast startup and low power dissipation solution.

Power-Saving Mode Operation

The proprietary Power-Saving Mode function provides linearly decrease the switching frequency under light-load conditions for higher efficiency. The feedback voltage, which is sampled from the voltage feedback loop, is taken as the reference. Once the feedback voltage exceeds the threshold voltage, the switching frequency starts to decrease. This Power-Saving Mode function dramatically reduces power consumption under light-load conditions. The frequency control also eliminates the audio noise at any loading conditions.

Burst Mode Operation

At zero load condition, majority of the power dissipation in a switching mode power supply is from switching loss on the MOSFET transistor, the core loss of the transformer and the loss on the snubber circuit. The magnitude of power loss is in proportion to the number of switching events within a fixed period of time. Reducing switching events leads to the reduction on the power loss and thus conserves the energy. The UTC **UB3846** enter burst mode at standby condition to minimize the switching loss and reduces the standby power consumption. The frequency control also eliminates the audio noise at any loading conditions. Power supplies using the UTC **UB3846** can easily meet even the strictest regulations regarding standby power consumption.

Switch Frequency Set

The maximum switch frequency is set to 68kHz. Switch frequency is modulated by output power P_{OUT} during IC operating. At no load or light load condition, most of the power dissipation in a switching mode power supply is from switching loss on the MOSFET transistor, the core loss of the transformer and the loss on the snubber circuit. The magnitude of power loss is in proportion to the number of switching events within a fixed period of time. So lower switch frequency at lower load, which more and more improve IC's efficiency at light load. At from no load to light load condition, The IC will operate at from Burst mode to Reducing Frequency Mode. The relation curve between f_{SW} and P_{OUT}/P_{OUT (MAX)} as followed FIG.1.

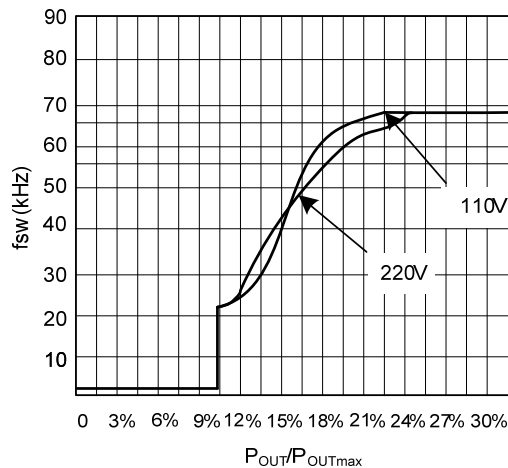

FIG.1 The relation curve between f_{SW} and relative output power P_{OUT}/ P_{OUT (MAX)}

■ OPERATION DESCRIPTION(Cont.)

Frequency Hopping For EMI Improvement

The Frequency hopping is implemented in the IC; there are two oscillators built-in the IC. The first oscillator is to set the normal switching frequency; the switching frequency is modulated with a period signal generated by the 2nd oscillator. The relation between the first oscillator and the 2nd oscillator as followed FIG.2. So the tone energy is evenly spread out, the spread spectrum minimizes the conduction band EMI and therefore eases the system design in meeting stringent EMI requirement.

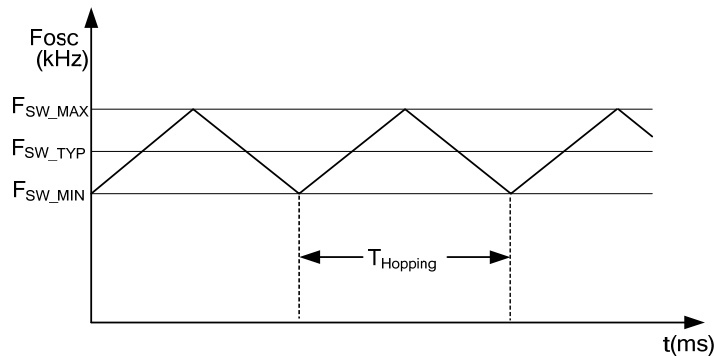

FIG.2 Frequency Hopping

Built-in Slope Compensation

Built-in slope compensation circuit adds voltage ramp onto the current sense input voltage for PWM generation, this greatly improves the close loop stability at CCM and prevents the sub-harmonic oscillation and thus reduces the output ripple voltage.

Leading-Edge Blanking

Each time the power MOSFET is switched on, a turn-on spike will inevitably occur at the sense-resistor. To avoid premature termination of the switching pulse, a 400ns leading-edge blanking time is built in. Conventional RC filtering can therefore be omitted. During this blanking period, the current-limit comparator is disabled and it cannot switch off the gate driver.

Constant Output Power Limit

When the SENSE voltage, across the sense resistor R_S , reaches the threshold voltage, around 0.8V, the output GATE drive will be turned off after a small propagation delay t_D . This propagation delay will introduce an additional current proportional to $t_D \times V_{IN} / L_p$. Since the propagation delay is nearly constant regardless of the input line voltage V_{IN} . Higher input line voltage will result in a larger additional current and hence the output power limit is also higher than that under low input line voltage. To compensate this variation for wide AC input range, the threshold voltage is adjusted by the V_{IN} current. Since V_{IN} pin is connected to the rectified input line voltage through a resistor R_{VIN} , a higher line voltage will generate higher V_{IN} current into the V_{IN} pin. The threshold voltage is decreased if the V_{IN} current is increased. Smaller threshold voltage, forces the output GATE drive to terminate earlier, thus reduce the total PWM turn-on time and make the output power equal to that of low line input. This proprietary internal compensation ensures a constant output power limit for wide AC input voltage from 90VAC to 264VAC.

Under Voltage Lockout (UVLO)

The turn-on and turn-off thresholds of the UTC **UB3846** are fixed internally at 14.2V/8.2V. During start-up, the hold-up capacitor must be charged to 14.2V through the start-up resistor, so that the UTC **UB3846** will be enabled. The hold-up capacitor will continue to supply V_{DD} until power can be delivered from the auxiliary winding of the main transformer. V_{DD} must not drop below 8.2V during this start-up process. This UVLO hysteresis window ensures that hold-up capacitor will be adequate to supply V_{DD} during start-up.

Gate Output

The UTC **UB3846** output stage is a fast totem pole gate driver. Cross conduction has been avoided to minimize heat dissipation, increase efficiency, and enhance reliability. A good tradeoff is achieved through dead time control. The low idle loss and good EMI system design is easier to achieve with this dedicated control scheme. An internal 18V clamp is added for MOSFET gate protection at higher than expected V_{DD} input.

■ OPERATION DESCRIPTION(Cont.)

Protection Controls

The IC takes on more protection functions such as OVP and OTP etc. In case of those failure modes for continual blanking time, the driver is shut down. Driver is reset after failure is eliminated.

OVP

The OVP will shut down the switching of the power MOSFET whenever $V_{DD} > V_{OVP}$. The OVP case as followed FIG.3. The test circuit as followed FIG.4.

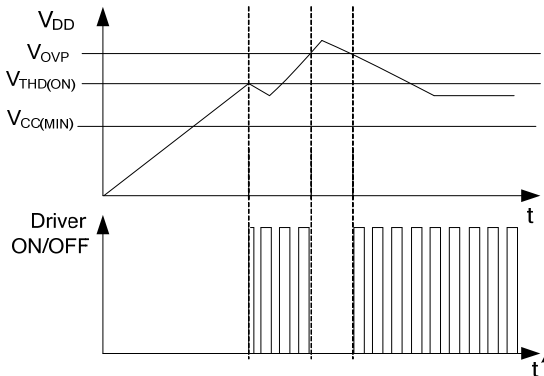

FIG.3 OVP case

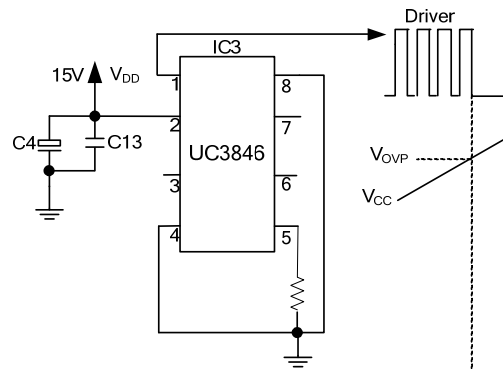

FIG.4 OVP test circuit

OTP

OTP will shut down driver when junction temperature $T_J > T_{(THR)}$ for continual a blanking time.

PCB Layout Note

Noise from the current sense or the control signal can cause significant pulse width jitter in continuous-conduction mode. While slope compensation helps alleviate these problems. Good placement and layout practices should be followed. Avoiding long PCB traces and component leads, locating compensation and filter components near the UTC **UB3846**, and increasing the power MOS gate resistance is advised.

■ REFERENCE CIRCUIT

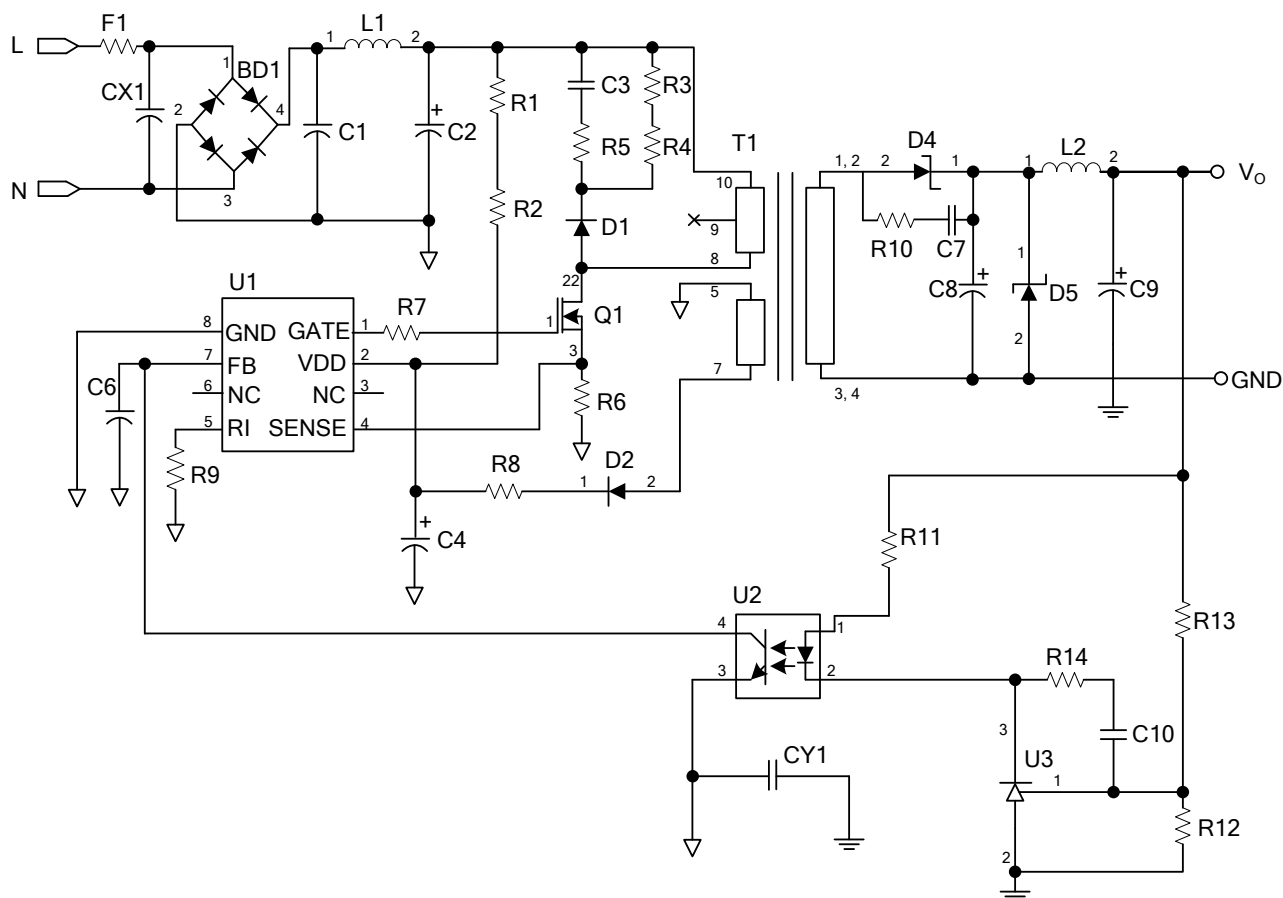

Reference	Component	Reference	Component
BD1	BD 1A/500V	L2	10 μ H 6mm
CX1 (Optional)	YC 472P/400V (Y1)	Q1	1N60
CY1 (Optional)	YC 102P/400V (Y1)	R1,R2	R 750K Ω 1206
C2	EC 10 μ F/400V 105 $^{\circ}$ C	R4,R3	R 47K Ω 1206
C1	CC 103P/500V	R5	R 47 Ω 1206
C3	CC 1000P/500V	R6	R 4.7 Ω 1206
C4	EC 10u/50V	R7	R 100 Ω 0805
C6	CC 472P 0805	R8	R 10 Ω 1206
C7 (Optional)	CC 102P/100V 1206	R10 (Optional)	R 10 Ω 1206
C8	EC 470u/10V 105 $^{\circ}$ C	R9	R 100K Ω 0805
C9	EC 220u/10V 105 $^{\circ}$ C	R11	R 100 Ω 1/8W
C10	CC 222P 0805	R12	R 33K Ω 0805
D1	Diode FRI07	R13	R 33K Ω 1/8W
D2	Diode FR102	R14	R 4.7K Ω 0805
D4	Diode SB360	T1	EE-16
D5 (Optional)	ZD 6.8V 0.5W	U1	IC UB3846
F1	R1 Ω /0.5W	U2	PC817
L1	20mH 6*8mm	U3	TL431

TYPICAL CHARACTERISTICS

Start-up Threshold Voltage ($V_{TH(ON)}$) vs Temperature

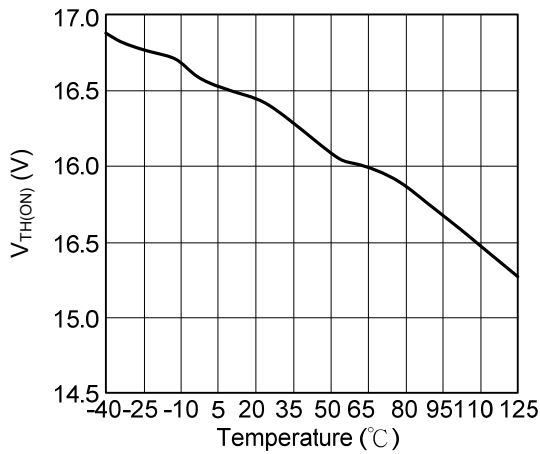

Min. Operating Voltage ($V_{DD(min)}$) vs Temperature

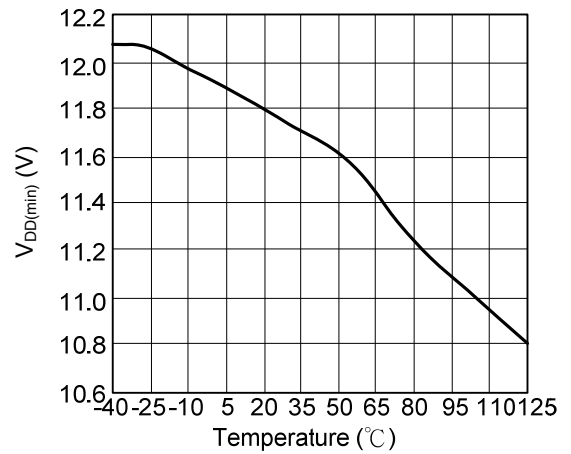

Start-up Current ($I_{DD ST}$) vs Temperature

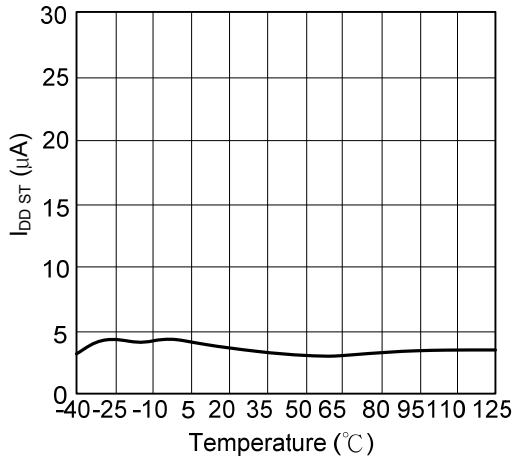

PWM Oscillator Frequency (F_{OSC}) vs Temperature

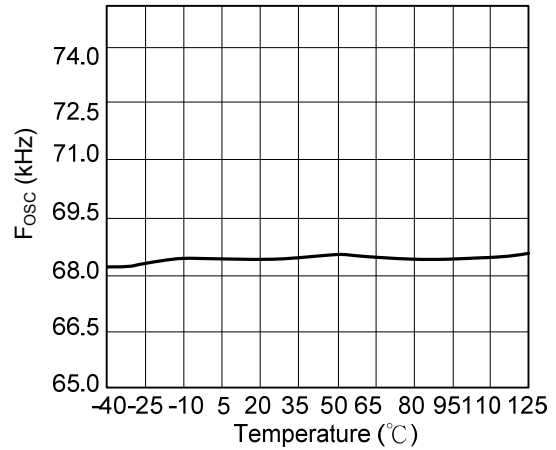

Frequency in green mode ($F_{OSC-green}$) vs Temperature

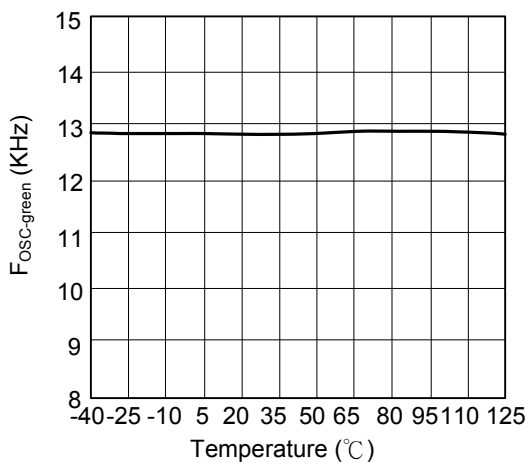

Max. Duty Cycle ($DC_{(MAX)}$) vs Temperature

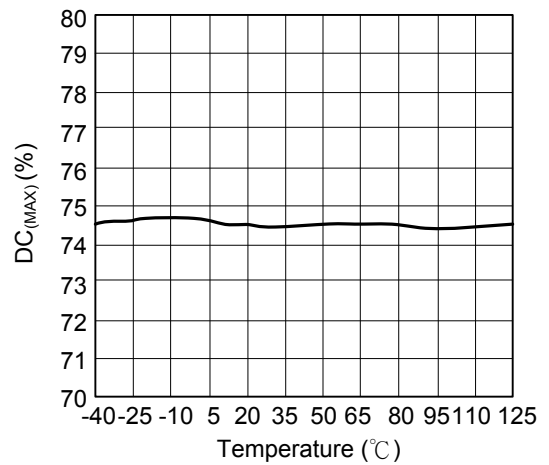

■ TYPICAL CHARACTERISTICS(Cont.)

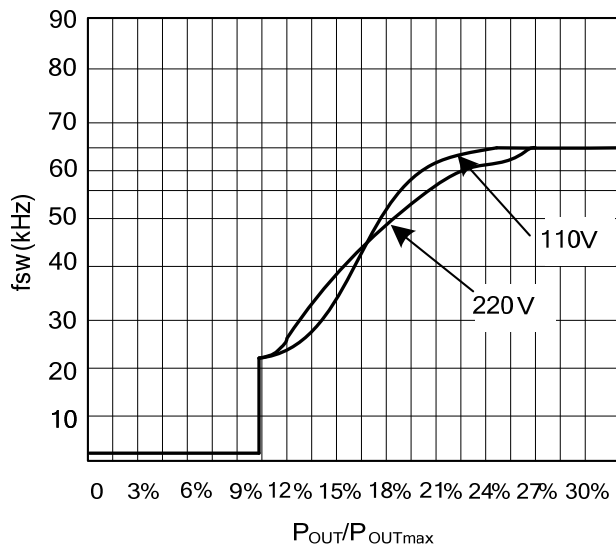

UTC assumes no responsibility for equipment failures that result from using products at values that exceed, even momentarily, rated values (such as maximum ratings, operating condition ranges, or other parameters) listed in products specifications of any and all UTC products described or contained herein. UTC products are not designed for use in life support appliances, devices or systems where malfunction of these products can be reasonably expected to result in personal injury. Reproduction in whole or in part is prohibited without the prior written consent of the copyright owner. The information presented in this document does not form part of any quotation or contract, is believed to be accurate and reliable and may be changed without notice.