



# TL432

## LINEAR INTEGRATED CIRCUIT

### 1.25V PRECISION ADJUSTABLE SHUNT REFERENCE REGULATORS

■ DESCRIPTION

The UTC **TL432** is a three-terminal adjustable shunt regulator highly accurate 1.25V band gap reference with 0.5%, 1% tolerance. The device offers thermal stability, wide operating current (50mA) and an extended temperature range of 0° to 85°C for operation in power supply applications. The UTC **TL432** offers a wide operating voltage range of up to 12V and is an excellent choice for voltage reference requirements in an isolated feedback circuit for 3.0V ~ 3.3V switching mode power supplies. The tight tolerance guarantees a lower design cost for the power supply manufacturer by virtually eliminating the need for an extra power supply manufacturing process of the power supply.

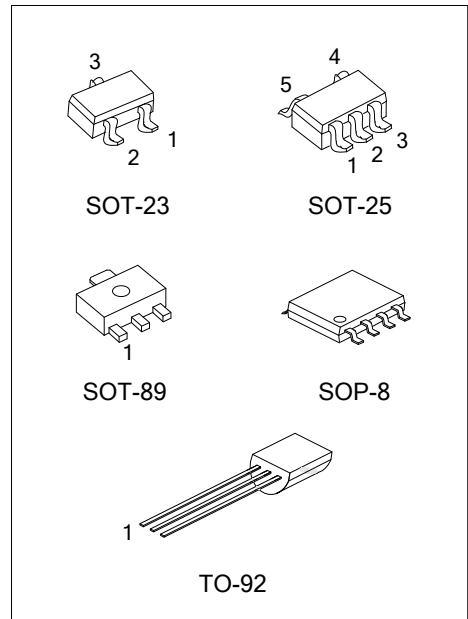

■ FEATURES

- \*Temperature-Compensated:50ppm/°C
- \*Internal amplifier with 50mA capability
- \*Nominal temperature range extended to 85°C
- \*Low frequency dynamic output impedance: <150Ω
- \*Low output noise

■ ORDERING INFORMATION

Ordering Number		Package	Pin Assignment								Packing	
Lead Free	Halogen Free		1	2	3	4	5	6	7	8		
-	TL432G-AE3-R	SOT-23	K	R	A	-	-	-	-	-	-	Tape Reel
-	TL432G-AB3-R	SOT-89	R	A	K	-	-	-	-	-	-	Tape Reel
-	TL432G-AF5-R	SOT-25	X	X	K	R	A	-	-	-	-	Tape Reel
TL432L-T92-B	TL432G-T92-B	TO-92	R	A	K	-	-	-	-	-	-	Tape Box
TL432L-T92-K	TL432G-T92-K	TO-92	R	A	K	-	-	-	-	-	-	Bulk
-	TL432G-S08-R	SOP-8	K	A	A	X	X	A	A	R	-	Tape Reel

Note: Pin Code: K: Cathode A: Anode R: Reference X: No Connection

<p>TL432G-AE3-R</p> <p>(1)Packing Type</p> <p>(2)Package Type</p> <p>(3)Green Package</p>	<p>(1) B: Tape Box, K: Bulk, R: Tape Reel</p> <p>(2) AE3: SOT-23, AB3: SOT-89, AF5: SOT-25, T92: TO-92, S08: SOP-8</p> <p>(3) G: Halogen Free and Lead Free, L: Lead Free</p>
---	---

### MARKING

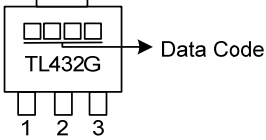
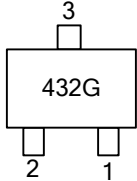
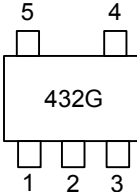
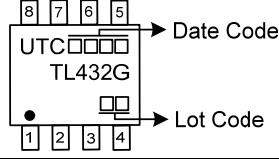
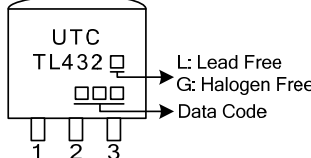
PACKAGE	MARKING
SOT-89	
SOT-23	
SOT-25	
SOP-8	
TO-92	

### BLOCK DIAGRAM

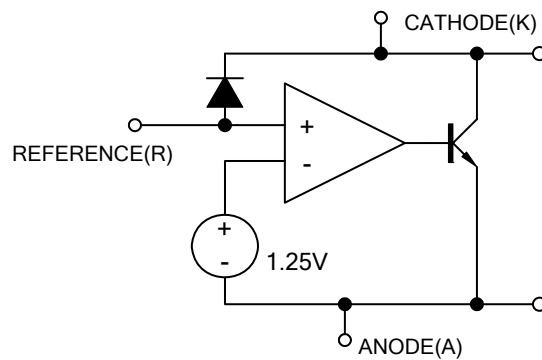

### ■ ABSOLUTE MAXIMUM RATINGS

PARAMETER	SYMBOL	RATING	UNIT
Cathode-Anode Reverse Breakdown	$V_{KA}$	15	V
Operating Cathode Current	$I_{KA}$	50	mA
Reference Input Current	$I_{REF}$	1	mA
Junction Temperature	$T_J$	+125	°C
Operating Temperature	$T_{OPR}$	-40 ~ +85	°C
Storage Temperature	$T_{STG}$	-40 ~ +150	°C

Note: Absolute maximum ratings are those values beyond which the device could be permanently damaged. Absolute maximum ratings are stress ratings only and functional device operation is not implied.

### ■ THERMAL DATA

PARAMETER	SYMBOL	RATING	UNIT
Junction to Ambient	SC-59/SOT-25	350	°C/W
	TO-92	100	°C/W
	SOP-8	150	°C/W
	SOT-89	220	°C/W

### ■ RECOMMENDED OPERATING CONDITIONS

PARAMETER	SYMBOL	MIN	TYP	MAX	UNIT
Cathode Voltage	$V_{KA}$	$V_{REF}$		15	V
Cathode Current	$I_K$	5	10		mA

### ■ ELECTRICAL CHARACTERISTICS ( $T_J=25^\circ\text{C}$ , $V_{KA}=V_{REF}$ , $I_K=10\text{mA}$ , unless otherwise specified.)

PARAMETER	SYMBOL	TEST CONDITIONS	MIN	TYP	MAX	UNIT
Refer Input Voltage	$V_{REF}$	$I_K=10\text{mA}$ , $V_K=V_{REF}$	1.243	1.250	1.256	V
			1.237	1.250	1.263	V
			1.225	1.250	1.275	V
Line Regulation	$\Delta V_{REF}$	$V_K=1.25 \sim 15\text{V}$		10	26	mV
Load Regulation	$\Delta V_{REF}$	$I_K=5 \sim 50\text{mA}$		6	15	mV
Temperature Deviation	$\Delta V_{REF}$	$0 < T_J < 85^\circ\text{C}$		2	6	mV
Reference Input Current	$I_{REF}$			3	6	$\mu\text{A}$
Reference Input Current Temperature Coefficient	$\Delta I_{REF}$	$0 < T_J < 85^\circ\text{C}$		0.3	0.6	$\mu\text{A}$
Minimum Cathode Current for Regulation	$I_{K(MIN)}$			0.6	1	mA
Off State Leakage	$I_{KA(OFF)}$	$V_{REF}=0\text{V}$ , $V_{KA}=15\text{V}$			500	nA

## TEST CIRCUIT

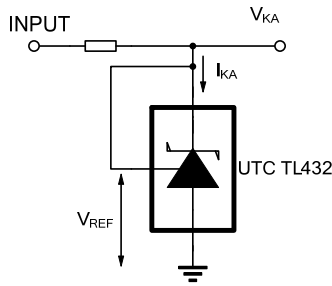

For  $V_{KA} = V_{REF}$

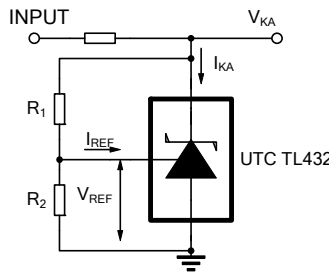

$V_{KA} = V_{REF} \times (1 + R_1/R_2) + I_{REF} \times R_1$   
For  $V_{KA} \geq V_{REF}$

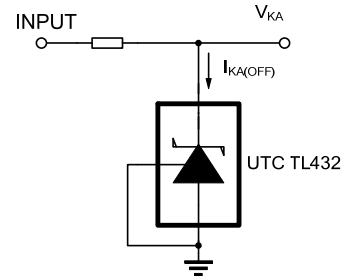

For  $I_{KA(OFF)}$

## APPLICATION CIRCUIT

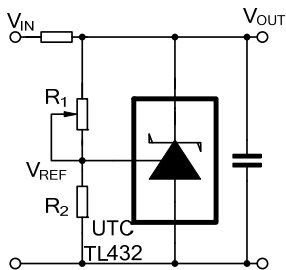

$$V_{OUT} = (1 + R_1/R_2) \times V_{REF}$$

Shutdown Regulator

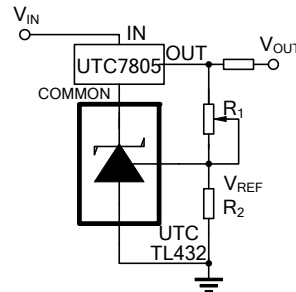

$$V_{OUT} = (1 + R_1/R_2) \times V_{REF}$$

Minimum  $V_{OUT} = V_{REF} + 5V$   
Output Control of a Three-Terminal Fixed Regulator

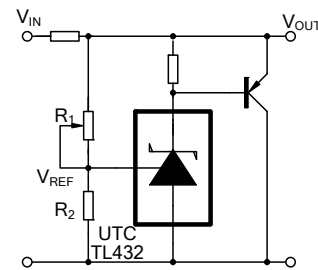

$$V_{OUT} = (1 + R_1/R_2) \times V_{REF}$$

Higher-current Shunt Regulator

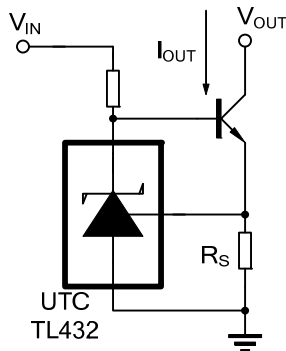

$$I_{OUT} = V_{REF}/R_S$$

Constant-current Sink

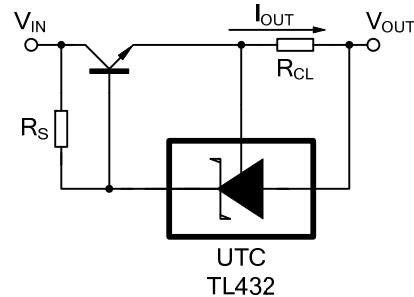

$$I_{OUT} = V_{REF}/R_{CL}$$

Current Limiting or Current Source

## TYPICAL CHARACTERISTICS

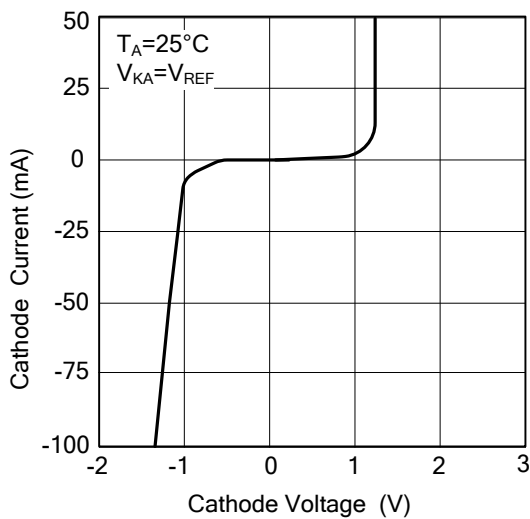
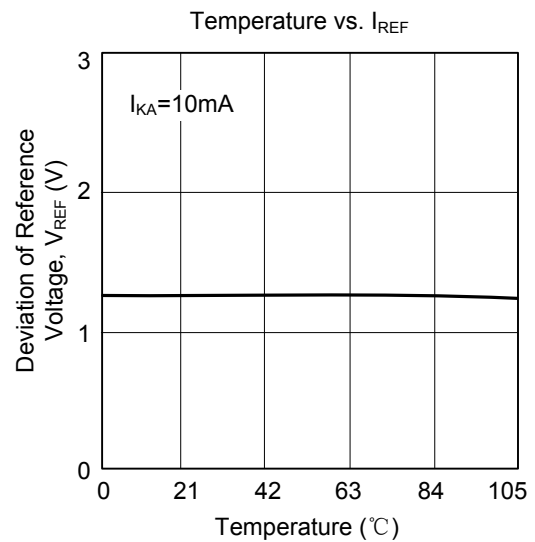
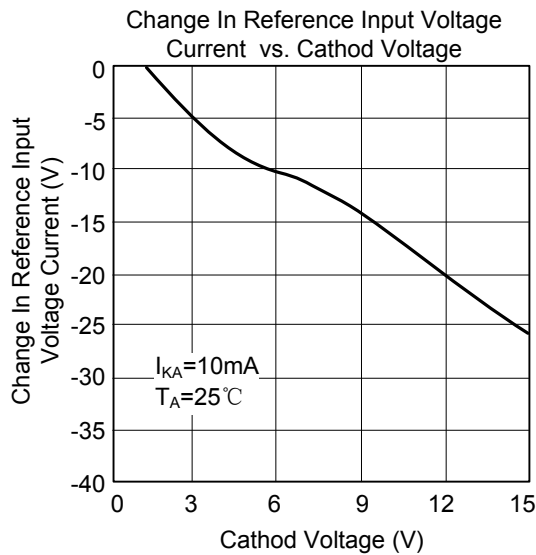
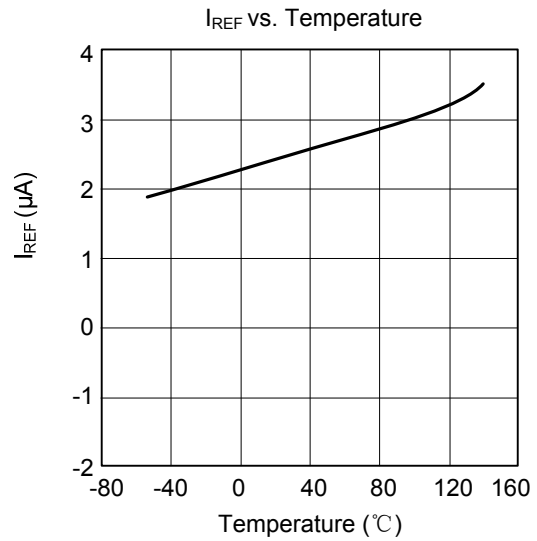
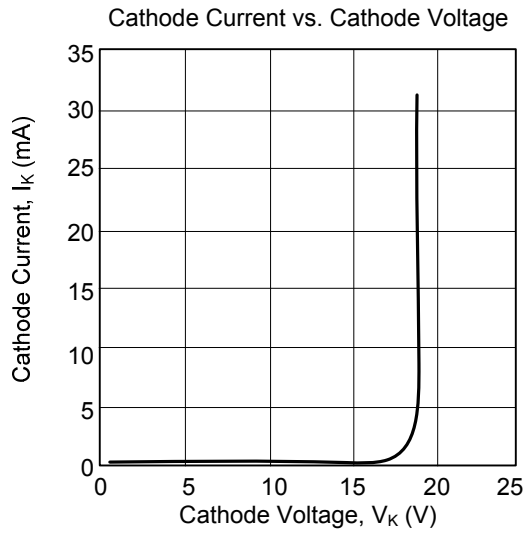

UTC assumes no responsibility for equipment failures that result from using products at values that exceed, even momentarily, rated values (such as maximum ratings, operating condition ranges, or other parameters) listed in products specifications of any and all UTC products described or contained herein. UTC products are not designed for use in life support appliances, devices or systems where malfunction of these products can be reasonably expected to result in personal injury. Reproduction in whole or in part is prohibited without the prior written consent of the copyright owner. The information presented in this document does not form part of any quotation or contract, is believed to be accurate and reliable and may be changed without notice.