



UPS1702

Preliminary

LINEAR INTEGRATED CIRCUIT

HIGH PERFORMANCE CURRENT MODE POWER SWITCH

DESCRIPTION

The UTC **UPS1702** is an integrated PWM controller and Power MOSFET specifically designed for current mode operation with minimal external components. The UTC **UPS1702** is designed to provide several special enhancements to satisfy the needs, for example, Power-Saving mode for low standby power (<0.3W), Frequency Hopping , Constant Output Power Limiting , Over Current Protection (OCP), Over Voltage Protection (OVP), Under Voltage Lock Out (UVLO), and Over Temperature Protection (OTP) etc. IC will be shutdown or can auto-restart in certain situations.

FEATURE

- * Internal High Voltage Start-up Circuit
- * Internal 700V Power MOSFET
- * Lower than 0.3W Standby Power Design
- * Gate Output Maximum Voltage Clamp(15V)
- * Over temperature protection
- * Over voltage protection
- * Leading edge blanking
- * Cycle-by-Cycle current limiting
- * Under Voltage Lock Out

ORDERING INFORMATION

Ordering Number		Package	Packing
Lead Free	Halogen Free		
UPS1702L-D08-T	UPS1702G-D08-T	DIP-8	Tube

<p>UPS1702L-D08-T</p> <p>(1) Packing Type (2) Package Type (3) Lead Free</p>	<p>(1) T: Tube (2) D08: DIP-8 (3) L: Lead Free, G: Halogen Free</p>
--------------------------------------------------------------------------------------	-----------------------------------------------------------------------------

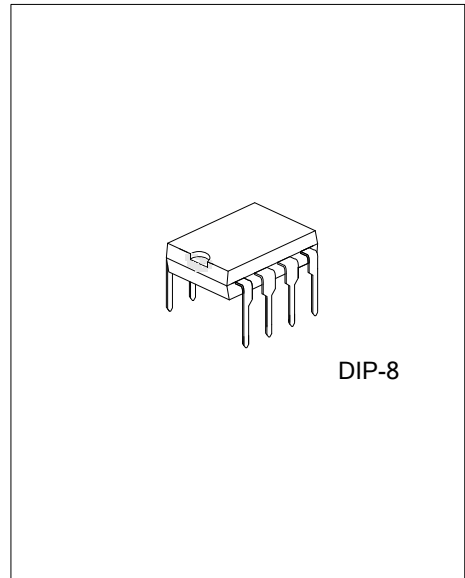

■ PIN CONFIGURATION

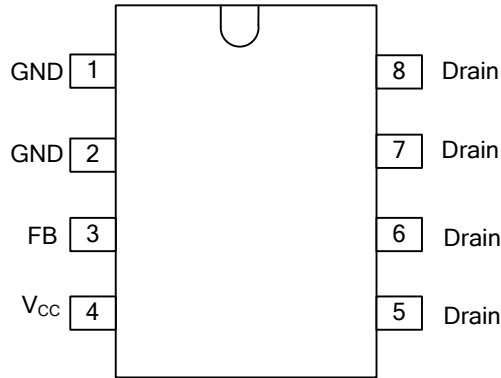

■ PIN DESCRIPTION

PIN NO.	PIN NAME	DESCRIPTION
1、 2	GND	Ground
3	FB	Feedback
4	V _{CC}	Supply voltage
5~8	Drain	Power MOSFET drain

■ BLOCK DIAGRAM

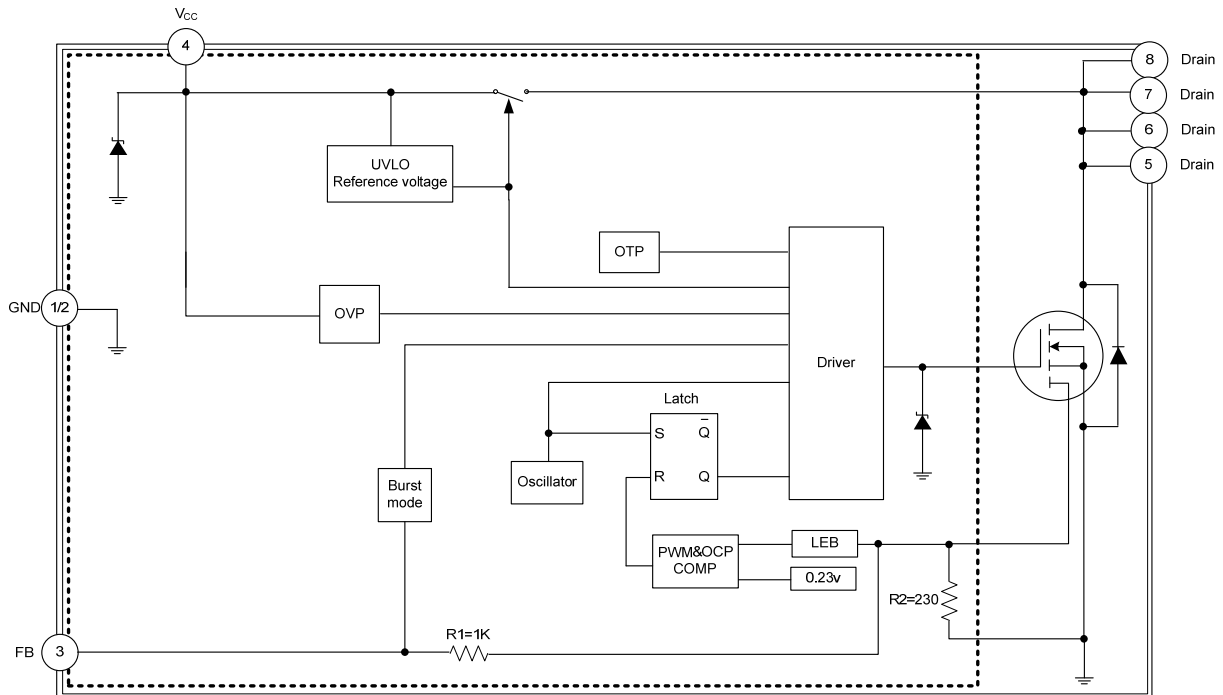

Notes: OTP (Over Temperature Protection)
 OVP (Over Voltage Protection)
 OCP (Over Current Protection)
 UVLO (Under Voltage Latch-Out)
 LEB (Led Edge Blanking)

■ ABSOLUTE MAXIMUM RATING ($T_A=25^{\circ}\text{C}$, unless otherwise specified)

PARAMETER	SYMBOL	RATINGS	UNIT
Switching Drain Source Voltage	$V_{DS(SW)}$	700	V
Supply Voltage	V_{CC}	30	V
Feedback Current	I_{FB}	3	mA
Junction Temperature	T_J	+150	$^{\circ}\text{C}$
Operating Temperature	T_{OPR}	-40 ~ +125	$^{\circ}\text{C}$
Storage Temperature	T_{STG}	-50 ~ +150	$^{\circ}\text{C}$

Note: Absolute maximum ratings are those values beyond which the device could be permanently damaged. Absolute maximum ratings are stress ratings only and functional device operation is not implied.

■ OPERATING RANGE

PARAMETER	SYMBOL	RATINGS	UNIT
Supply Voltage	V_{CC}	8.6 ~ 22	V

■ ELECTRICAL CHARACTERISTICS ($T_A=25^{\circ}\text{C}$, $V_{CC}=15\text{V}$, unless otherwise specified)

PARAMETER	SYMBOL	TEST CONDITIONS	MIN	TYP	MAX	UNIT
SUPPLY SECTION						
Start Up Charge Current	I_{CH}	$V_{DS}=100\text{V}$, $V_{CC}=0\sim V_{CCON}$			1	mA
Start Up Current	I_{ST}	$V_{CC} = V_{CCON}-0.2\text{V}$		6	45	μA
Supply Current with switch	I_{OP}	$I_{FB}=0.5\text{mA}$, $I_D=50\text{mA}$		2	6.5	mA
UNDER-VOLTAGE LOCKOUT SECTION						
Start Threshold Voltage	V_{CCON}		13.5	15	16.5	V
Min. Operating Voltage	V_{CCOFF}		8	9	10	V
INTERNAL VOLTAGE REFERENCE						
CONTROL SECTION						
I_{FB} to I_D Current Gain	G_{FB-D}			560		
Feedback Source Shutdown Current	I_{FBSD}			900		μA
FB Pin Input Impedance	R_{FB}			1200		Ω
Burst-Mode Out FB Voltage	$V_{FB(OUT)}$			0.94		V
Burst-Mode Enter FB Voltage	$V_{FB(IN)}$			1.05		V
Normal initial Switching frequency	$F_{(SW)}$		54	60	66	kHz
Frequency Deviation VS V_{CC}	F_{DV}	$V_{CC}=10$ to 22V			5	%
Frequency Deviation VS Temperature	F_{DT}	$T_A = -40$ to 105°C			5	%
PROTECTION SECTION						
OVP threshold	V_{OVP}			23		V
OTP threshold	$T_{(THR)}$		130	150	170	$^{\circ}\text{C}$
CURRENT LIMITING SECTION						
Peak Current Limitation	I_{LIM}	$V_{FB}=0\text{V}$	0.56	0.7	0.84	A
Minimum Turn On Time	$t_{ON(MIN)}$			680		nS
POWER MOSFET SECTION						
Drain-Source Breakdown Voltage	V_{DSS}	$V_{FB}=2\text{V}$, $I_D=250\mu\text{A}$	700			V
Turn-on voltage between gate and source	V_{TH}	$V_{DS}=V_{GS}$, $I_D=250\mu\text{A}$	2		4	V
Off State Drain Current	I_{DSS}	$V_{DS}=500\text{V}$, $V_{FB}=2\text{V}$			100	μA
Static Drain-Source On-State Resistance	$R_{DS(ON)}$	$V_{GS}=10\text{V}$, $I_D=0.4\text{A}$			5	Ω
Rise Time	t_R	$V_{DD} = 300\text{V}$, $I_D = 4.0\text{A}$ $RG=25\Omega$ (Note 1, 2)		45	100	ns
Fall Time	t_F			35	80	ns
Drain Capacitance	C_{OSS}	$V_{DS}=25\text{V}$		40		pF

Note: 1. Pulse Test: Pulse width $\leq 300\mu\text{s}$, Duty cycle $\leq 2\%$
2. Essentially independent of operating temperature

■ FUNCTIONAL DESCRIPTION

The internal reference voltages and bias circuit work at $V_{CC} > V_{THD(ON)}$, and shutdown at $V_{CC} < V_{CC(MIN)}$.

(1) High Voltage Start up switch Circuit

At startup, an internal high-voltage current source supplies the internal bias and charges the external capacitor connected to the V_{CC} pin. When V_{CC} reaches $V_{THD(ON)}$, the IC begins switching and the internal high-voltage current source is disabled. The IC continues its normal switching operation and the power is supplied from the auxiliary transformer winding unless V_{CC} goes below the stop voltage of $V_{CC(MIN)}$.

(2) Switching Frequency Limit

The UTC UPS1702 have a constant switching frequency of 60kHz.

(3) Protection section

The IC takes on more protection functions such as OVP and OTP etc. In case of those failure modes for continual blanking time, the driver is shut down. At the same time, IC enters auto-restart, V_{CC} power on and driver is reset after V_{CC} power on again.

OVP

OVP will shutdown the switching of the power MOSFET whenever $V_{CC} > V_{OVP}$. The OVP case as followed Fig. 1 the test circuit as followed Fig. 2.

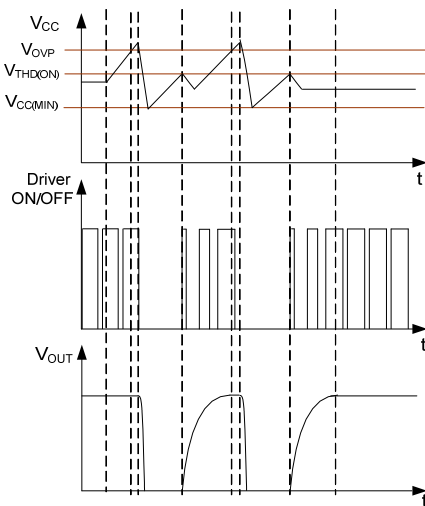

Fig.1 OVP case

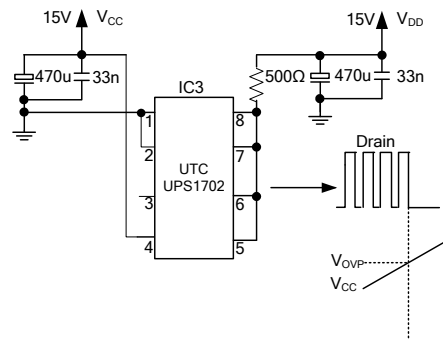

Fig.2 OVP test circuit

OTP

OTP will shut down driver and latch-off when junction temperature $T_J > T_{(THR)}$, and IC will be release on when temperature decreasing under $T_{(THR)} - 30$ and powering on again.

(4) The Gain of FB pin to Drain Current Limiting

$$I_{LIM} = G_{FB-D} \times 0.23V \times (R2 || R1)$$

(5) Driver Output Section

The driver-stage drives the gate of the MOSFET and is optimized to minimize EMI and to provide high circuit efficiency. This is done by reducing the switch on slope when reaching the MOSFET threshold. This is achieved by a slope control of the rising edge at the driver's output. The output driver is clamped by an internal 15V Zener diode in order to protect power MOSFET transistors against undesirable gate over voltage.

(6) Inside Power MOSFET

Specific Power MOSFET parameter is as "Power MOSFET SECTION" in electrical characteristics table.

■ TYPICAL APPLICATION CIRCUIT

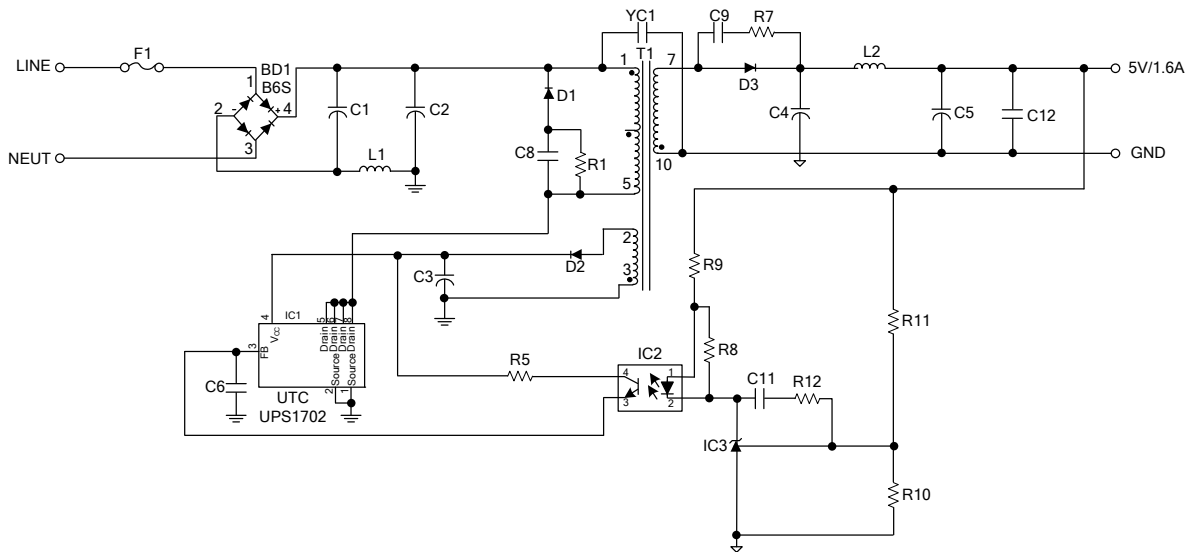

Fig. 3 UTC UPS1702 Typical Application Circuit

Table1. Components reference description for UTC UPS1702 application circuit

DESIGNATOR	PART TYPE	DESIGNATOR	PART TYPE	DESIGNATOR	PART TYPE
C1	10 μ F/400V	R1	100K Ω	D1	FR107
C2	10 μ F/400V	R5	6.8K Ω	D2	RS1D
C3	10 μ F/50V	R7	30 Ω	D3	SR39
C4	470 μ F/16V	R8	2.2K Ω	IC1	UPS1702
C5	220 μ F/16V	R9	510 Ω	IC2	PC-817
C6	103pF	R10	5.1K Ω	IC3	TL431
C8	102pF/1KV	R11	5.1K Ω	YC1	102pF/400V
C9	102pF/100V	R12	15K Ω	T1	EE-19
C11	103pF			L1	1mH
C12	103pF			L2	2 μ H
				F1	1A/250V
				BD1	B6S

UTC assumes no responsibility for equipment failures that result from using products at values that exceed, even momentarily, rated values (such as maximum ratings, operating condition ranges, or other parameters) listed in products specifications of any and all UTC products described or contained herein. UTC products are not designed for use in life support appliances, devices or systems where malfunction of these products can be reasonably expected to result in personal injury. Reproduction in whole or in part is prohibited without the prior written consent of the copyright owner. The information presented in this document does not form part of any quotation or contract, is believed to be accurate and reliable and may be changed without notice.