



UPSL100

Preliminary

LINEAR INTEGRATED CIRCUIT

HIGH PRECISION CC PRIMARY-SIDE LED CONTROLLER

DESCRIPTION

The UTC **UPSL100** is a high performance offline PSR controller for LED lighting, which can achieve accurate LED current and low system cost for an isolated lighting application in a single stage converter. Consequently, opto-coupler and TL431 could be eliminated. Constant Current (CC) control is intergrated as shown in the figure below.

In CC control, the current can be adjusted externally by the sense resistor R_S at CS pin. The chip consumes low start up current and very low operation current (typical $350\mu A$), it can achieve high efficiency and low standby power consumption.

The UTC **UPSL100** offers comprehensive protection coverage with auto-recovery features including open loop protection, short circuit protection, cycle-by-cycle current limiting, V_{DD} over voltage protection, built-in leading edge blanking, V_{DD} under voltage lockout (UVLO), etc.

FEATURES

- * Primary-side sensing and regulation without TL431 and opto-coupler
- * High precision constant current regulation at universal AC input
- * Low system cost and high efficiency
- * Built-in primary winding inductance compensation
- * Programmable CC regulation
- * Drivability for BJT switch
- * Short circuit protection
- * Ultra low start-up current (Typ. $1\mu A$)
- * Open loop protection
- * Built-in leading edge blanking (LEB)
- * Cycle-by-cycle current limiting
- * V_{DD} under voltage lockout with hysteresis
- * V_{DD} over voltage protection

ORDERING INFORMATION

Ordering Number		Package	Packing
Lead Free	Halogen Free		
UPSL100-AF5-R	UPSL100G-AF5-R	SOT-25	Tape Reel

<p>UPSL100L-AF5-T</p> <p>(1)Packing Type</p> <p>(2)Package Type</p> <p>(3)Halogen Free</p>	<p>(1) T: Tube, R: Tape Reel</p> <p>(2) AF5: SOT-25</p> <p>(3) L: Lead Free, G: Halogen Free</p>
--	--

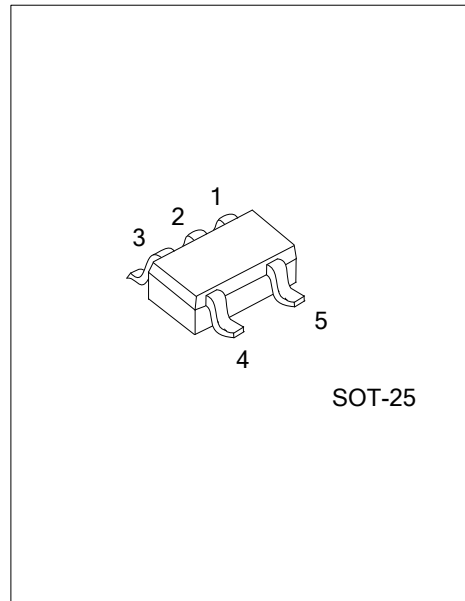

■ PIN CONFIGURATION

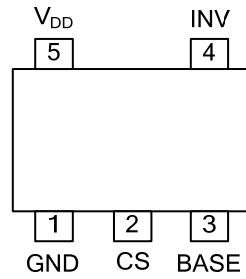

■ PIN DESCRIPTION

PIN NO.	PIN NAME	DESCRIPTION
1	GND	Ground
2	CS	Current sense input.
3	BASE	Base driver with current limit for power BJT.
4	INV	The voltage feedback from auxiliary winding.
5	V_{DD}	Power supply.

■ BLOCK DIAGRAM

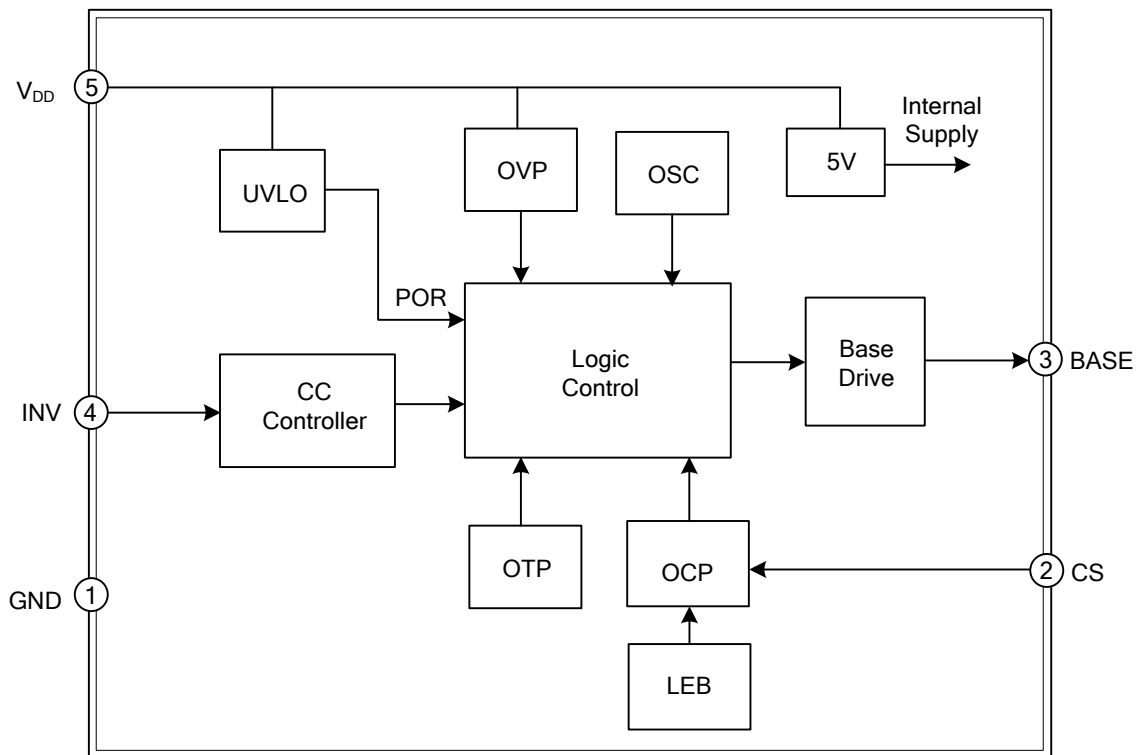

■ ABSOLUTE MAXIMUM RATING

PARAMETER	SYMBOL	RATINGS	UNIT
V _{DD} Voltage		-0.3~30	V
BASE Voltage		-0.3~7	V
CS Input Voltage		-0.3~7	V
INV Input Voltage		-0.3~7	V
Junction Temperature	T _J	-40~150	°C
Storage Temperature	T _{STG}	-55~150	°C

Note: Absolute maximum ratings are those values beyond which the device could be permanently damaged. Absolute maximum ratings are stress ratings only and functional device operation is not implied.

■ CAL CHARACTERISTICS (V_{DD}=15V, T_A=25°C, if not otherwise noted.)

PARAMETER	SYMBOL	TEST CONDITIONS	MIN	TYP	MAX	UNIT
Supply Voltage (V_{DD}) Section						
Start up Current	I _{START-UP}	V _{DD} =11V		0.1	3	μA
Static Current	I _{STATIC}	V _{DD} =15V		350	500	μA
V _{DD} Under Voltage Lockout Enter	U _{VLO(ON)}		5.0	6.0	7.6	V
V _{DD} Under Voltage Lockout Exit	U _{VLO(OFF)}		11.5	12.5	13.5	V
V _{DD} Over Voltage Protection	V _{DD_OVP}		23	26	29	V
Current Sense Input Section						
Lead Time	T _{LEB}			0.5		μS
Over Current Threshold	V _{th_OCP}		1.21	1.23	1.25	V
OCP Propagation Delay	T _{d_OC}	From OCP Comparator to Base Drive		100		nS
INV Input Section						
Maximum Pause	T _{PAUSE_MAX}		710	765	810	μS
BASE Drive Section						
Base Sourcing Maximum Current	I _{S_MAX}		40	50	60	mA
Base Sourcing Current After Pre-off	I _{S_PREOFF}		1.9	2.4	2.9	mA
Base Drive Low Side On Resistor	R _{DSON_L}			1.8		Ω

■ OPERATION DESCRIPTION

The UTC **UPSL100** is a cost effective PSR controller optimized for off-line LED lighting applications which can achieve accurate LED current. It operates in primary side sensing and regulation, eliminating the need of opto-coupler and TL431, which makes the solution simple, small and low cost. Proprietary built-in CC control meeting accurate LED current.

Startup Current and Start up Control

Startup current of UTC **UPSL100** is designed to be very low so that V_{DD} can be charged up quickly. A large value startup resistor can therefore be used to minimize the power loss in application.

Operating Current

The operating current of UTC **UPSL100** is designed to be very low so that V_{DD} could be charged up above UVLO threshold and starts up quickly. Good efficiency and very low standby power is achieved with the low operating current.

Adjustable CC point

In UTC **UPSL100**, the CC point can be externally adjusted by external current sense resistor R_S at CS pin as illustrated in typical application diagram. The larger R_S is, the smaller CC point is, and vice versa.

Principle of CC Operation

To support the UTC **UPSL100** proprietary CC control, system needs to be designed in DCM mode for flyback system. For flyback operating in DCM, the output current I_{out} is given by

$$I_{out} = \frac{1}{2} L_P F_{SW} I_P^2 \eta / V_{out} \tag{1}$$

Where L_P indicates the inductance of primary winding and I_P is the peak current of primary winding.

Refer to the equation 1, the change of the primary winding inductance results in the change of the constant output current. To compensate the change from variations of primary winding inductance, the switching frequency is locked by an internal loop such that the switching frequency is

$$F_{SW} = \frac{1}{2T_{Demag}} \tag{2}$$

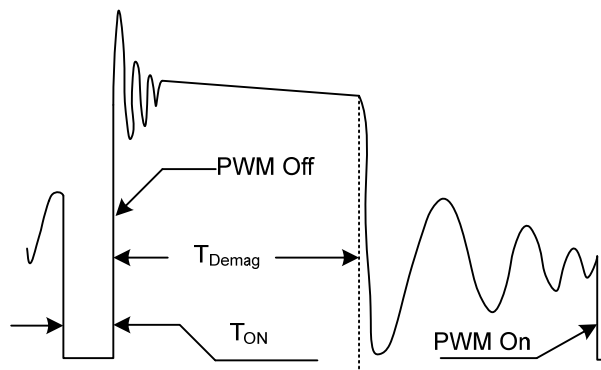

Figure. 1 Auxiliary voltage waveform

Since T_{Demag} is inversely proportional to the inductance, as a result, the product L_P and f_{SW} is constant, thus output current will not change as primary winding inductance changes. Up to $\pm 10\%$ variation of the primary winding inductance can be compensated.

The output LED current is

$$I_{out} = \frac{1}{4} N \frac{V_{thoc}}{R_S} \tag{3}$$

Where N is the ratio of transformer between primary side winding and secondary winding.

■ OPERATION DESCRIPTION(Cont.)

CS and LEB

Cycle-by-Cycle current limiting is offered in UTC **UPSL100**. The switch current is detected by a sense resistor into the CS pin. An internal leading edge blanking circuit chops off the sensed voltage spike at initial power BJT on state so that the external RC filtering on sense input is no longer needed.

Protection Control

Good power supply system reliability is achieved with its rich protection features including Cycle-by-Cycle current limiting (OCP), V_{DD} over voltage protection, feedback loop open protection, short circuit protection and Under Voltage Lockout on V_{DD} (UVLO).

Because of the coupling between secondary winding and auxiliary winding, the voltage at V_{DD} pin will rise up if the output of secondary side is open-circuited, when V_{DD} pin voltage is larger than 27V, the UTC **UPSL100** will stop sending pulses to BASE pin and enter auto restart mode.

If the output of secondary side is short-circuited, the V_{DD} voltage will drop down and the system enters under voltage lockout protection.

Base Drive

The drive is a push pull stage with supply voltage V_{DD} . It provides the driving current for the external power bipolar transistor. The output signal is current limit to I_{s_max} (typical 30mA).

■ TYPICAL APPLICATION CIRCUIT

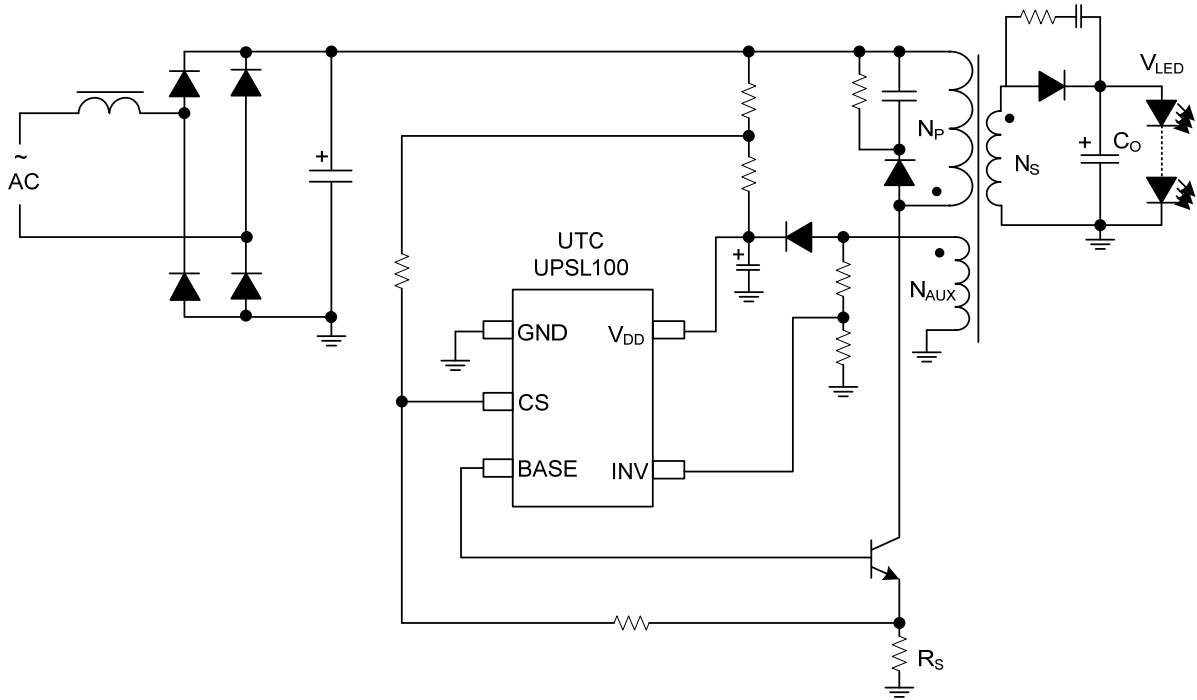

UTC assumes no responsibility for equipment failures that result from using products at values that exceed, even momentarily, rated values (such as maximum ratings, operating condition ranges, or other parameters) listed in products specifications of any and all UTC products described or contained herein. UTC products are not designed for use in life support appliances, devices or systems where malfunction of these products can be reasonably expected to result in personal injury. Reproduction in whole or in part is prohibited without the prior written consent of the copyright owner. The information presented in this document does not form part of any quotation or contract, is believed to be accurate and reliable and may be changed without notice.