



UPSD1630

Preliminary

CMOS IC

PSR, SINGLE STAGE, AC-DC LED DRIVER WITH ACTIVE PFC

DESCRIPTION

The UTC **UPSD1630** is a primary-side-control AC-DC LED driver which can achieve high power factor and accurate LED current for an isolate lighting application in a single stage converter.

The LED current can be controlled accurately from the primary side information. It can significantly simplify the LED lighting system design by eliminating the secondary side feedback components and the opto-coupler.

The UTC **UPSD1630** integrates power factor correction function and works in DCM and constant TOFF time mode for reducing the harmonic current emission (THD).

The UTC **UPSD1630** achieves high precision output current regulation and high power efficiency. It offers comprehensive protection coverage with auto-recovery features including V_{DD} over voltage protection, OTP, over current protection (OCP), output over voltage protection, output short circuit protection (SCP), leading edge blanking, V_{DD} under voltage lockout, etc.

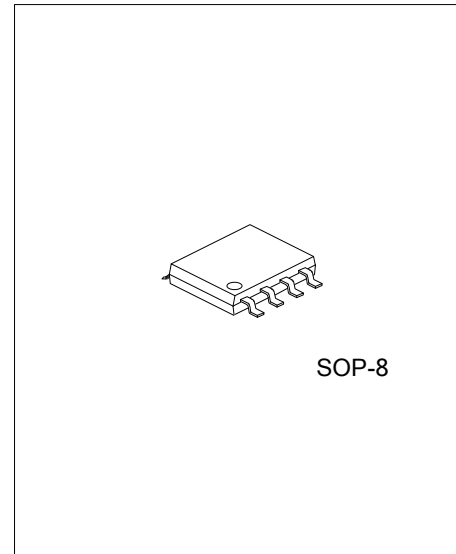

SOP-8

FEATURES

- * $\pm 3\%$ constant current regulation at universal AC input
- * Primary side control without TL431 and opto-coupler
- * Built-in power factor correction
- * Up to 50W power drivability
- * Flyback topology in DCM operation
- * Driver MOSFET switch
- * Built-in leading edge blanking
- * Cycle-by-cycle current limiting
- * Under-voltage lockout
- * V_{DD} over voltage protection
- * Output over voltage protection
- * Output short circuit protection
- * Power on soft-start

ORDERING INFORMATION

Ordering Number		Package	Packing
Lead Free	Halogen Free		
UPSD1630L-S08-T	UPSD1630G-S08-T	SOP-8	Tube
UPSD1630L-S08-R	UPSD1630G-S08-R	SOP-8	Tape Reel

<p>UPSD1630L-S08-R</p> <p>(1)Packing Type. (2)Package Type (3)Lead Free</p>	<p>(1) R: Tape Reel (2) S08: SOP-8 (3) L: Lead Free, G:Halogen Free</p>
---	---

■ PIN CONFIGURATION

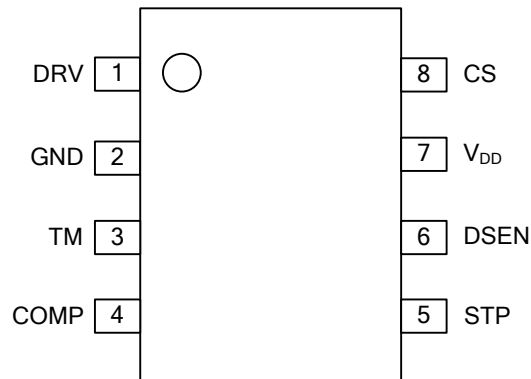

■ PIN DESCRIPTION

PIN NO.	PIN NAME	DESCRIPTION
1	DRV	Gate drive for power MOSFET.
2	GND	Ground.
3	TM	Test pin. Always tie to ground.
4	COMP	Connect a capacitor to ground for frequency compensation.
5	STP	Start-up pin.
6	DSEN	The voltage feedback from auxiliary winding.
7	V _{DD}	Power supply.
8	CS	Current sense input.

■ BLOCK DIAGRAM

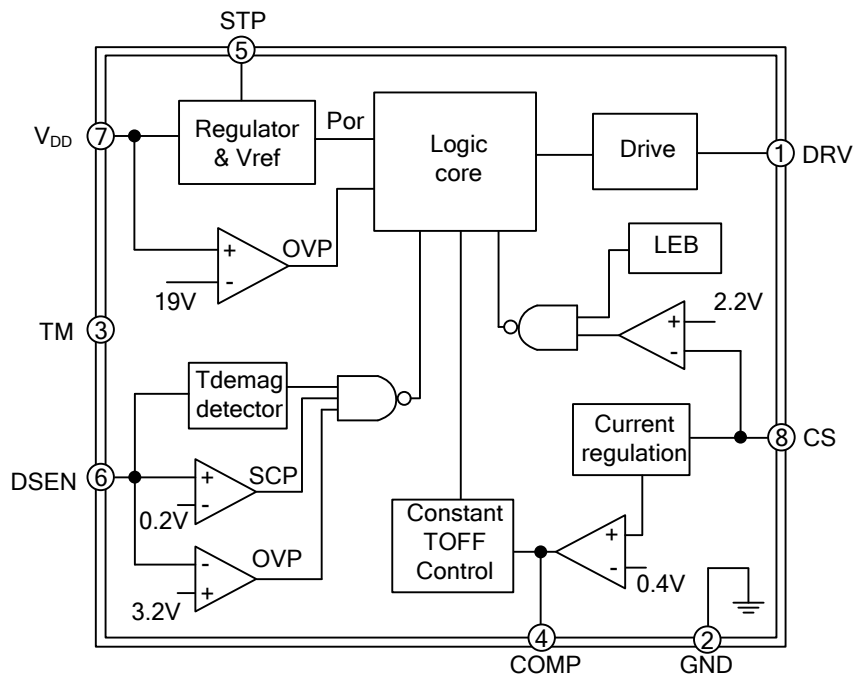

■ ABSOLUTE MAXIMUM RATING

PARAMETER	SYMBOL	RATINGS	UNIT
STP, V _{DD} , DRV Voltage		-0.3~25	V
All Other Pins Voltage		-0.3~6	V
Junction Temperature	T _J	150	°C
Storage Temperature	T _{STG}	-55~150	°C

Note: Absolute maximum ratings are those values beyond which the device could be permanently damaged.
 Absolute maximum ratings are stress ratings only and functional device operation is not implied.

■ RECOMMENDED OPERATING CONDITIONS

PARAMETER	SYMBOL	RATINGS	UNIT
Supply Voltage	V _{CC}	7.2~18	V
Operating Temperature	T _{OPR}	-40~105	°C

■ THERMAL RESISTANCE

PARAMETER	SYMBOL	RATINGS	UNIT
Case to Ambient	θ _{CA}	128	°C/W

■ ELECTRICAL CHARACTERISTICS (V_{DD}=12V, T_A=25°C unless otherwise stated.)

PARAMETER	SYMBOL	TEST CONDITIONS	MIN	TYP	MAX	UNIT
Start-up						
Start up Current	I _{START}			25	50	μA
Lower Threshold Voltage of V _{DD}	UVLO	V _{DD} Pin Ramp Down		7.2	8.5	V
Start-Up Voltage	V _{START}	V _{DD} Pin Ramp Up	17.5	18.5	20	V
Supply Current						
Quiescent Current	I _Q	No Switching		1.2		mA
Operating Current	I _{CC}	Fs=70kHz		3		mA
Control Loop						
Primary Current Sense Voltage	V _{FB}		392	400	408	mV
Upper Limit of COMP	V _{COMPH}		2.1	2.2	2.4	V
Off Time of DRV	T _{OFF}		10	11	12	μS
Short Circuit Protection Threshold at DSEN Pin	SCP			200		mV
Over Voltage Protection Threshold at DSEN	OVP1			3.2		V
Over Voltage Protection Threshold at V _{DD} pin	OVP2			19.2	23.5	V
Current Sense						
Leading Edge Blanking of CS	LEB			300		nS
Over Current Protection at CS Pin	OCP			2.2	2.4	V
Thermal Protection						
Over Temperature Protection	OTP			150		°C
Over Temperature Release Hysteresis				15		°C
Drive Stage						
Rising Time (Note 1)	T _R	C _L =1nF, DRV Pin Falls from V _{DD} to 0V		50		nS
Falling Time (Note 1)	T _F	C _L =1nF, DRV Pin Rises from 0V to V _{DD}		30		nS

Note: 1. Guaranteed by design.

■ APPLICATION INFORMATION

The UTC **UPSD1630** is a primary-side-control AC-DC LED driver which can achieve high power factor and accurate LED current for an isolate lighting application in a single stage converter. The LED current can be controlled accurately from the primary side information and integrates power factor correction function and works in DCM and constant OFF time mode for reducing the harmonic current emission (THD).

Startup Control

A soft-start function is implemented to prevent the transformer from entering into CCM. The V_{DD} pin of UTC **UPSD1630** is charged through a startup resistor. When the V_{DD} voltage reaches $V_{TH(ON)}$, the internal startup circuit is disabled and the IC turns on. Then, the STP pin is clamped to lower than V_{DD} voltage about 0.2V.

Operating Current

The Operating current of UTC **UPSD1630** is as low as 3mA. Good efficiency and very low standby power can be achieved.

Constant Current Operation

UTC **UPSD1630** use the primary side constant current control method to accurately control the LED current. The LED real current can be approximated as:

$$I_{LED} \approx \frac{1}{2} \times \frac{N_P}{N_S} \frac{0.4V}{R_{CS}}$$

Where N_P is primary winding, N_S is secondary winding; R_{CS} is an external current sensing resistor.

Power Factor Correction

The primary side current increases linearly from zero to peak value, during the external MOSFET on-time. When the primary current reaches the threshold, UTC **UPSD1630** turns off the power MOSFET immediately. After a constant OFF time, T_{OFF} , UTC **UPSD1630** turns on the power MOSFET again. The peak current threshold follows the rectified sinusoidal-shape of main line voltage. As a result, the envelope of the inductor current is sinusoidal-shaped, high power factor is therefore achieved in this way.

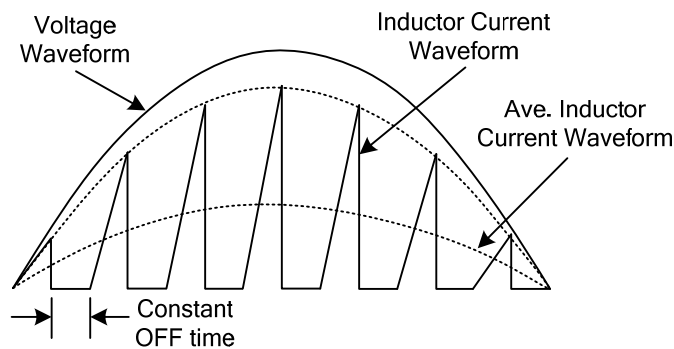

Figure 1. Power Factor Correction

Over-voltage Protection

UTC **UPSD1630** built-in two over-voltage protection schemes:

(1) If DSEN pin's voltage is detected above 3.2V for three times, UTC **UPSD1630** turns off the PWM switching signal, and V_{DD} voltage gradually drops to UVLO threshold, and the system will be re-started. The threshold voltage of the output over voltage protection can be easily defined as:

$$V_{OUT_OVP} = 3.2 \times \left(1 + \frac{R5}{R6}\right) \times \frac{N_S}{N_A} - V_{D8}$$

Where N_S is the secondary winding, N_A is auxiliary winding, V_{D8} is the forward bias of the secondary side rectifier diode.

(2) If V_{DD} pin's voltage exceeds 19.2V three times, UTC **UPSD1630** turns off the PWM switching signal, and V_{DD} gradually drops to UVLO threshold, and then the system will be re-started.

■ APPLICATION INFORMATION (Cont.)**Short-circuit Protection**

The short-circuit protection is triggered if the DSEN pin voltage is detected below 0.2V for a continuous time of 640 μ s. The gate drive switching will be turned off, and a restart process will be kicked off when the V_{DD} voltage drops below the UVLO threshold.

This re-start process will repeat if the short-circuit condition continues to exist.

Current Sensing and Leading Edge Blanking

Cycle-by-cycle current limiting is offered in UTC **UPSD1630**. The switch current is detected by a sense resistor into the CS pin. When the power switch is turned on, a turn-on spike will occur on this resistor. A 500ns leading-edge blanking is built in to avoid false-termination of the switching pulse so that the external RC filtering is no longer needed.

Other Protection Control

Good power supply system reliability is achieved with its comprehensive protection features including V_{DD} over voltage protection, OTP, over current protection (OCP), output over voltage protection, output short circuit protection (SCP), leading edge blanking, V_{DD} under voltage lockout, etc.

V_{DD} is supplied by transformer auxiliary winding output. The output of UTC **UPSD1630** is shutdown when V_{DD} drops below $V_{TH(OFF)}$ and the power converter enters power on start-up sequence thereafter.

■ TYPICAL APPLICATION CIRCUIT

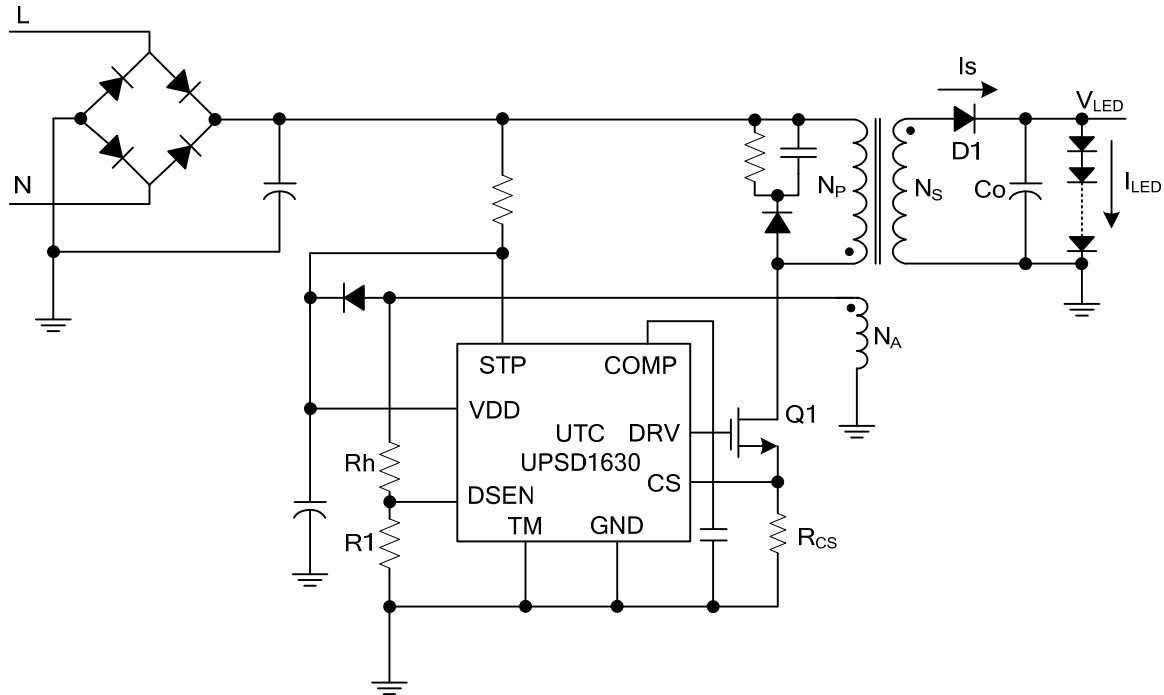

UTC assumes no responsibility for equipment failures that result from using products at values that exceed, even momentarily, rated values (such as maximum ratings, operating condition ranges, or other parameters) listed in products specifications of any and all UTC products described or contained herein. UTC products are not designed for use in life support appliances, devices or systems where malfunction of these products can be reasonably expected to result in personal injury. Reproduction in whole or in part is prohibited without the prior written consent of the copyright owner. The information presented in this document does not form part of any quotation or contract, is believed to be accurate and reliable and may be changed without notice.