

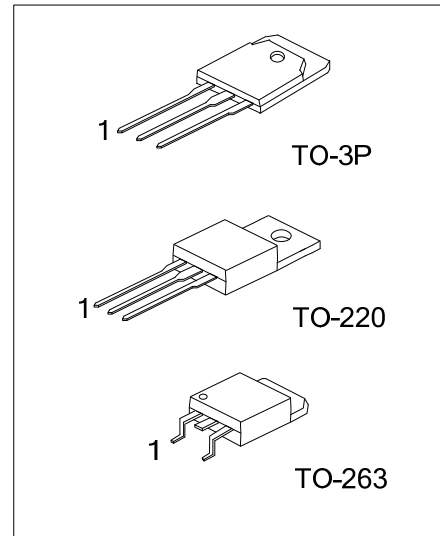

# BU941Z

## NPN SILICON TRANSISTOR

NPN POWER DARLINGTON  
HIGH VOLTAGE IGNITION  
COIL DRIVER



■ FEATURES

- \* NPN Darlington
- \* Integrated antiparallel collector-emitter diode

■ APPLICATIONS

- \* High ruggedness electric ignitions

■ INTERNAL SCHEMATIC DIAGRAM

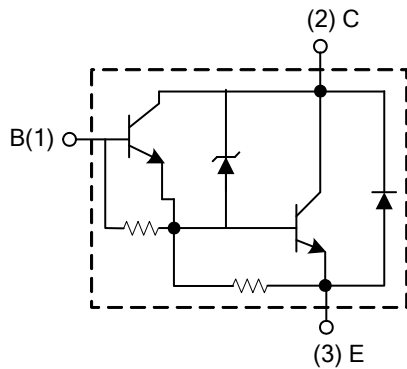

■ ORDERING INFORMATION

Ordering Number		Package	Pin Assignment			Packing
Lead Free	Halogen Free		1	2	3	
BU941ZL-T3P-T	BU941ZG-T3P-T	TO-3P	B	C	E	Tube
BU941ZL-TA3-T	BU941ZG-TA3-T	TO-220	B	C	E	Tube
BU941ZL-TQ2-T	BU941ZG-TQ2-T	TO-263	B	C	E	Tube
BU941ZL-TQ2-R	BU941ZG-TQ2-R	TO-263	B	C	E	Tape Reel

Note: Pin assignment: E: Emitter B: Base C: Collector

<p>BU941ZL-T3P-T</p> <p>(1) Packing Type</p> <p>(2) Package Type</p> <p>(3) Green Package</p>	<p>(1) T: Tube, R: Tape Reel</p> <p>(2) T3P: TO-3P, TA3: TO-220, TQ2: TO-263</p> <p>(3) L: Lead Free, G: Halogen Free and Lead Free</p>
---	---

■ MARKING

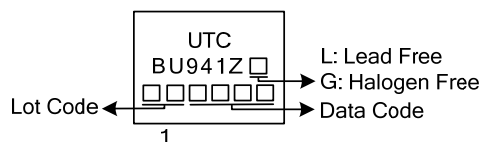

### ■ ABSOLUTE MAXIMUM RATINGS

PARAMETER		SYMBOL	RATINGS	UNIT
Collector-Emitter Voltage		$V_{CEO}$	350	V
Emitter-Base Voltage		$V_{EBO}$	5	V
Collector Current		$I_C$	15	A
Collector Peak Current		$I_{CM}$	30	A
Base Current		$I_B$	1	A
Base Peak Current		$I_{BM}$	5	W
Total Power Dissipation ( $T_C=25^\circ\text{C}$ )	TO-3P	$P_D$	155	W
	TO-220/TO263		150	W
Junction Temperature		$T_J$	+175	$^\circ\text{C}$
Storage Temperature		$T_{STG}$	-65 ~ +175	$^\circ\text{C}$

Note Absolute maximum ratings are those values beyond which the device could be permanently damaged. Absolute maximum ratings are stress ratings only and functional device operation is not implied.

### ■ ELECTRICAL CHARACTERISTICS ( $T_C=25^\circ\text{C}$ , unless otherwise specified)

PARAMETER	SYMBOL	TEST CONDITIONS	MIN	TYP	MAX	UNIT
Clamping Voltage	$V_{CL}^*$	$I_C=10\text{mA}$	350		500	V
Collector Cut-Off Current	$I_{CEO}$	$V_{CE}=300\text{V}$			100	$\mu\text{A}$
		$V_{CE}=300\text{V}, T_J=125^\circ\text{C}$			0.5	mA
Emitter Cut-off Current	$I_{EBO}$	$V_{EB}=5\text{V}, I_C=0$			20	mA
Collector-Emitter Saturation Voltage	$V_{CE(SAT)}^*$	$I_C=8\text{A}, I_B=100\text{mA}$			1.6	V
		$I_C=10\text{A}, I_B=250\text{mA}$			1.8	
		$I_C=12\text{A}, I_B=300\text{mA}$			2	
Base-Emitter Saturation Voltage	$V_{BE(SAT)}^*$	$I_C=8\text{A}, I_B=100\text{mA}$			2.2	V
		$I_C=10\text{A}, I_B=250\text{mA}$			2.5	
		$I_C=12\text{A}, I_B=300\text{mA}$			2.7	
DC Current Gain	$h_{FE}^*$	$V_{CE}=10\text{V}, I_C=5\text{A}$	300			
Diode Forward Voltage	$V_F$	$I_F=10\text{A}$			2.5	V
Functional Test		$V_{CC}=24\text{V}, V_{CLAMP}=400\text{V}, L=7\text{mH}$ (see Functional Test Circuit)	10			A
Fall Time	$t_F$	$V_{CC}=12\text{V}, V_{CLAMP}=300\text{V}, V_{BE}=0,$ $R_{BE}=47\Omega, L=7\text{mH}, I_C=7\text{A}, I_B=70\text{mA}$		0.5		$\mu\text{s}$
Storage Time	$t_S$	(see Fig.1)		15		

\*Pulsed: Pulse duration=300 $\mu\text{s}$ , duty cycle 1.5%

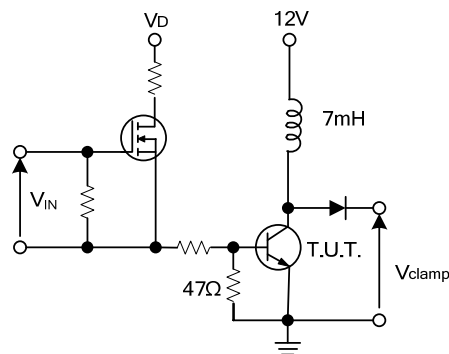
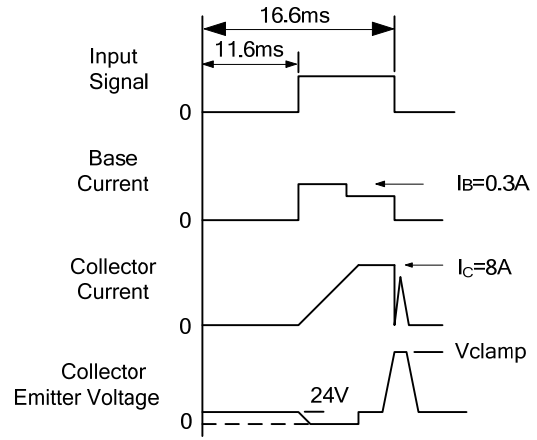
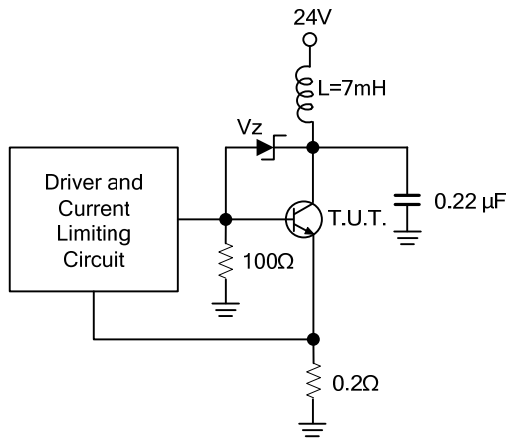
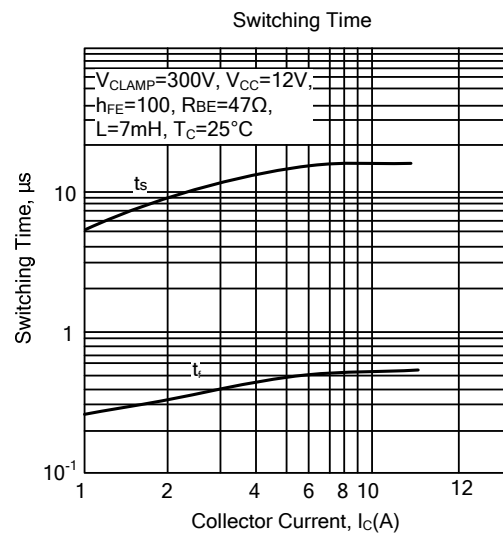
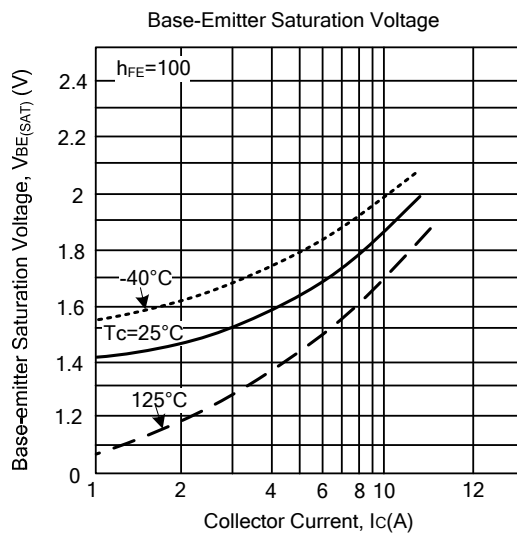
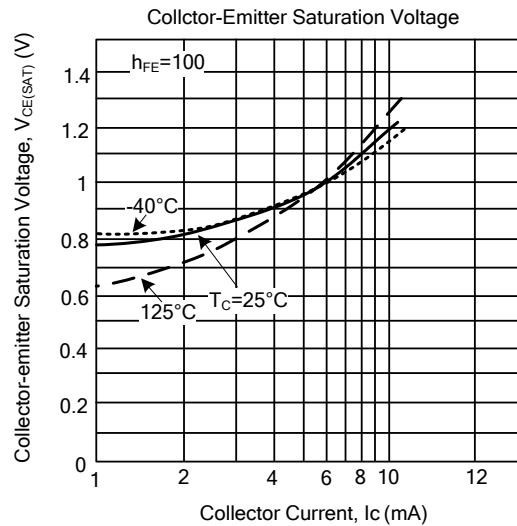
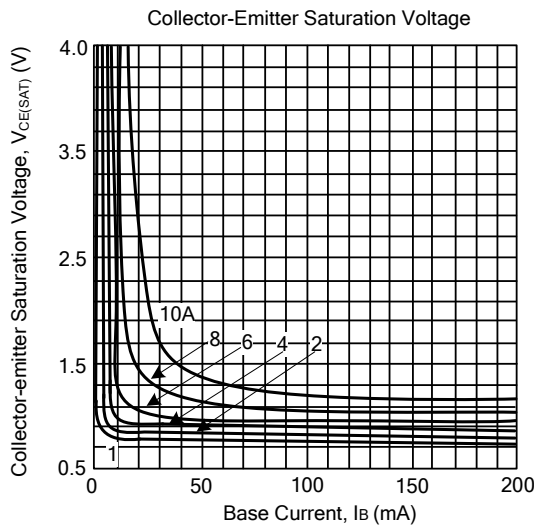
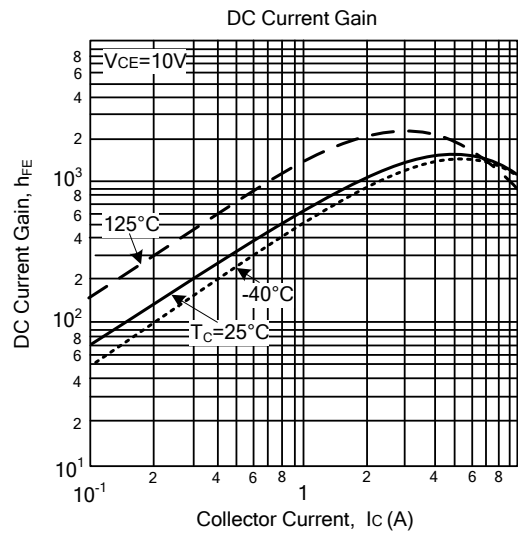
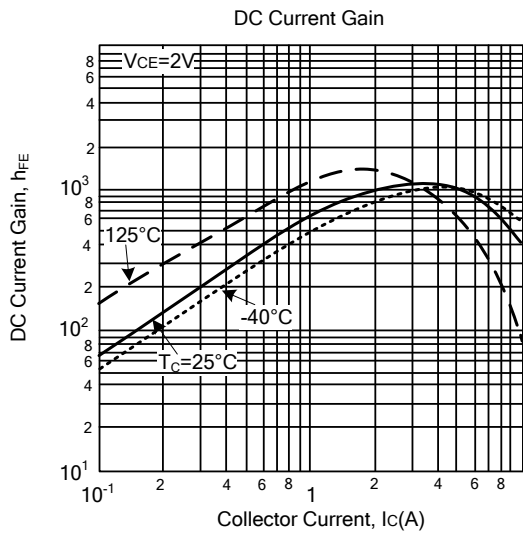

Fig. 1 Switching Time Test Circuit

## FUNCTION TEST CIRCUIT



## TYPICAL CHARACTERISTICS



■ TYPICAL CHARACTERISTICS(Cont.)

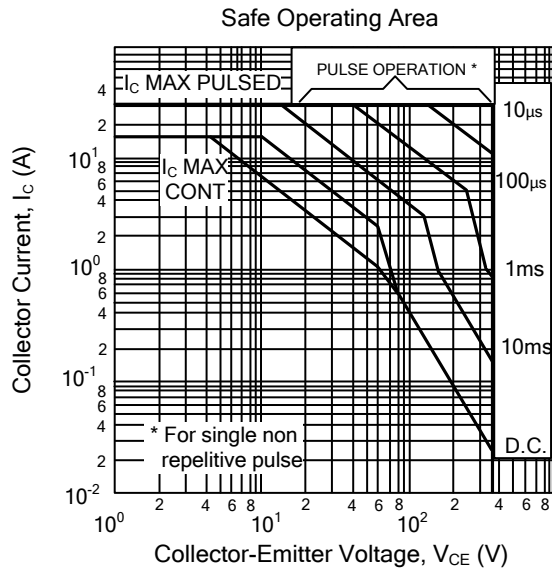

UTC assumes no responsibility for equipment failures that result from using products at values that exceed, even momentarily, rated values (such as maximum ratings, operating condition ranges, or other parameters) listed in products specifications of any and all UTC products described or contained herein. UTC products are not designed for use in life support appliances, devices or systems where malfunction of these products can be reasonably expected to result in personal injury. Reproduction in whole or in part is prohibited without the prior written consent of the copyright owner. The information presented in this document does not form part of any quotation or contract, is believed to be accurate and reliable and may be changed without notice.