



US112S/N

SCR

SCRS

DESCRIPTION

The UTC **US112S/N** is suitable to fit all modes of control found in applications such as overvoltage crowbar protection, motor control circuits in power tools and kitchen aids, in-rush current limiting circuits, capacitive discharge ignition, voltage regulation circuits.

SYMBOL

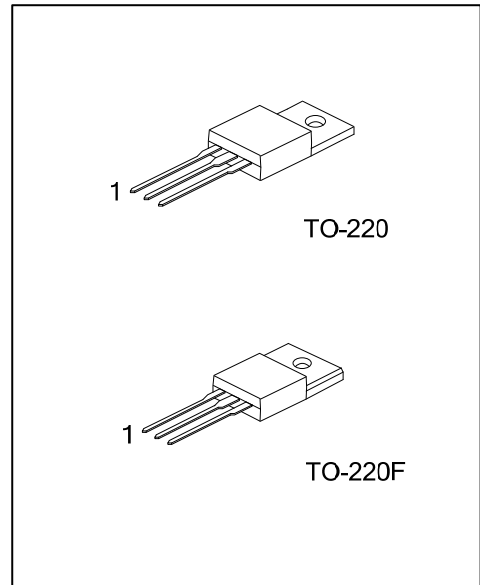
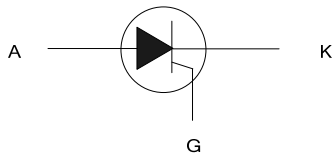

ORDERING INFORMATION

Ordering Number		Package	Pin Assignment			Packing
Lead Free	Halogen Free		1	2	3	
US112SL-x-TA3-T	US112SG-x-TA3-T	TO-220	K	A	G	Tube
US112SL-x-TF3-T	US112SG-x-TF3-T	TO-220F	K	A	G	Tube
US112NL-x-TA3-T	US112NG-x-TA3-T	TO-220	K	A	G	Tube
US112NL-x-TF3-T	US112NG-x-TF3-T	TO-220F	K	A	G	Tube

Note: Pin Assignment: K: Cathode A: Anode G: Gate

<p>US112SL-x-TA3-T</p> <ul style="list-style-type: none"> (1) Packing Type (2) Package Type (3) Peak Voltage (4) Lead Free 	<ul style="list-style-type: none"> (1) T: Tube (2) TA3: TO-220, TF3: TO-220F (3) 4: 400V, 6: 600V, 8: 800V (4) L: Lead Free, G: Halogen Free
--	--

MARKING INFORMATION

PACKAGE	MARKING	
	US112S	US112N
TO-220 TO-220F		

■ ABSOLUTE MAXIMUM RATING

PARAMETER	SYMBOL	RATING	UNIT
Repetitive Peak Off-State Voltages	US112S/N-4	400	V
	US112S/N-6	600	
	US112S/N-8	800	
RMS On-State Current (180° Conduction Angle) ($T_C = 110^\circ\text{C}$)	$I_{T(RMS)}$	12	A
Average On-State Current (180° Conduction Angle) ($T_C = 110^\circ\text{C}$)	$I_{T(AV)}$	8	A
Non Repetitive Surge Peak On-State Current ($T_J = 25^\circ\text{C}$)	$t_p=8.3\text{ms}$	146	A
	$t_p=10\text{ms}$	140	
I^2t Value For Fusing ($t_p = 10 \text{ ms}$, $T_J = 25^\circ\text{C}$)	I^2t	98	A ² S
Critical Rate Of Rise Of On-State Current ($I_G = 2 \times I_{GT}$, $t_R \leq 100 \text{ ns}$, $T_J = 125^\circ\text{C}$)	dI/dt	50	A/ μs
Peak Gate Current ($t_p=20\mu\text{s}$, $F = 60 \text{ Hz}$, $T_J = 125^\circ\text{C}$)	I_{GM}	4	A
Peak Reverse Gate Voltage	US112N V_{RGM}	5	V
Average Gate Power Dissipation ($T_J = 125^\circ\text{C}$)	$P_{G(AV)}$	1	W
Storage Temperature	T_{STG}	-40 ~ +150	$^\circ\text{C}$
Junction Temperature	T_J	+125	$^\circ\text{C}$

Note: Absolute maximum ratings are those values beyond which the device could be permanently damaged.

Absolute maximum ratings are stress ratings only and functional device operation is not implied.

■ THERMAL DATA

PARAMETER	SYMBOL	RATINGS	UNIT
Junction to Case	θ_{JA}	60	K/W
Junction to Ambient	TO-220	1.3	K/W
	TO-220F	2.3	

■ ELECTRICAL CHARACTERISTICS ($T_J=25^\circ\text{C}$ unless otherwise specified)

US112S(SENSITIVE)

PARAMETER	SYMBOL	TEST CONDITIONS	MIN	TYP	MAX	UNIT
Gate Trigger Current	I_{GT}	$V_D = 12\text{V}$, $R_L = 140\Omega$			200	μA
Gate Trigger Voltage	V_{GT}	$V_D = 12\text{V}$, $R_L = 140\Omega$			0.8	V
Gate Non-Trigger Voltage	V_{GD}	$V_D = V_{DRM}$, $R_L = 3.3\text{k}\Omega$, $R_{GK} = 1\text{k}\Omega$, $T_J = 125^\circ\text{C}$	0.1			V
Reverse Gate Voltage	V_{RG}	$I_{RG} = 10 \mu\text{A}$	8			V
Holding Current	I_H	$I_T = 50\text{mA}$, $R_{GK} = 1\text{k}\Omega$			5	mA
Latching Current	I_L	$I_G = 1\text{mA}$, $R_{GK} = 1\text{k}\Omega$			6	mA
Circuit Rate of Change of Off-State Voltage	dV/dt	$V_D = 67\% V_{DRM}$, $R_{GK} = 220\Omega$	5			V/ μs
On-State Voltage	V_{TM}	$I_{TM} = 24\text{A}$, $t_p = 380 \mu\text{s}$			1.6	V
Threshold Voltage	V_{T0}	$T_J = 125^\circ\text{C}$			0.85	V
Dynamic Resistance	R_D	$T_J = 125^\circ\text{C}$			30	m Ω
Off-State Leakage Current	I_{DRM}	$V_{DRM} = V_{RRM}$, $R_{GK} = 220\Omega$			5	μA
	I_{RRM}	$V_{DRM} = V_{RRM}$, $R_{GK} = 220\Omega$, $T_J = 125^\circ\text{C}$			2	mA

■ ELECTRICAL CHARACTERISTICS(Cont.)

US112N(SENSITIVE)

PARAMETER	SYMBOL	TEST CONDITIONS	MIN	TYP	MAX	UNIT
Gate Trigger Current	I_{GT}	$V_D = 12\text{ V}, R_L = 33\Omega$	2		15	mA
Gate Trigger Voltage	V_{GT}	$V_D = 12\text{ V}, R_L = 33\Omega$			1.3	V
Gate Non-Trigger Voltage	V_{GD}	$V_D = V_{DRM}, R_L = 3.3k\Omega, T_J = 125^\circ\text{C}$	0.2			V
Holding Current	I_H	$I_T = 500\text{mA}$ Gate open			30	mA
Latching Current	I_L	$I_G = 1.2 I_{GT}$			60	mA
Circuit Rate of Change of Off-State Voltage	dV/dt	$V_D = 67\% V_{DRM}$ Gate open, $T_J = 125^\circ\text{C}$	200			V/ μs
On-State Voltage	V_{TM}	$I_{TM} = 24\text{ A}, t_p = 380\ \mu\text{s}$			1.6	V
Threshold Voltage	V_{T0}	$T_J = 125^\circ\text{C}$			0.85	V
Dynamic Resistance	R_D	$T_J = 125^\circ\text{C}$			30	m Ω
Off-State Leakage Current	I_{DRM}	$V_{DRM} = V_{RRM}$			5	μA
	I_{RRM}	$V_{DRM} = V_{RRM}, T_J = 125^\circ\text{C}$			2	mA

■ TYPICAL CHARACTERISTICS

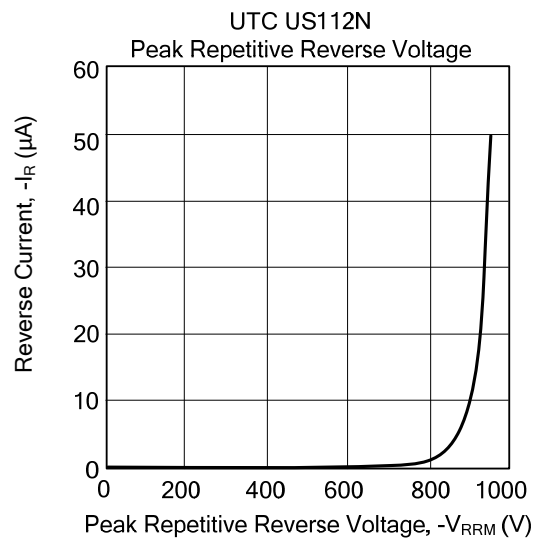
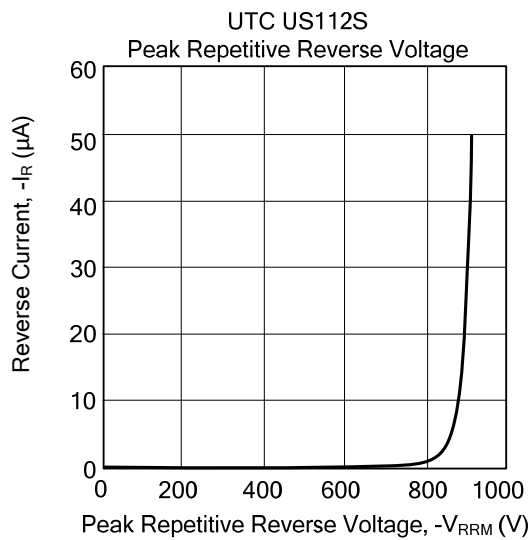

UTC assumes no responsibility for equipment failures that result from using products at values that exceed, even momentarily, rated values (such as maximum ratings, operating condition ranges, or other parameters) listed in products specifications of any and all UTC products described or contained herein. UTC products are not designed for use in life support appliances, devices or systems where malfunction of these products can be reasonably expected to result in personal injury. Reproduction in whole or in part is prohibited without the prior written consent of the copyright owner. The information presented in this document does not form part of any quotation or contract, is believed to be accurate and reliable and may be changed without notice.