



U74HC374

CMOS IC

OCTAL EDGE-TRIGGERED D-TYPE FLIP-FLOPS WITH 3-STATE OUTPUTS

DESCRIPTION

The UTC **U74HC374** is an octal edge-triggered D-type flip-flop with 3-state outputs and 8 channels.

FEATURES

- * Operate from 2V to 6V
- * Max t_{PD} of 46ns at 4.5 V , $T_a = 25^{\circ}C$
- * Max I_{CC} of 8 μA , $T_a = 25^{\circ}C$
- * Typical $V_{OL} < 0.17V$ at $V_{CC} = 4.5V, I_{OUT} = -6mA, T_a = 25^{\circ}C$
- * Typical $V_{OH} > 4.3V$ at $V_{CC} = 4.5V, I_{OUT} = 6mA, T_a = 25^{\circ}C$

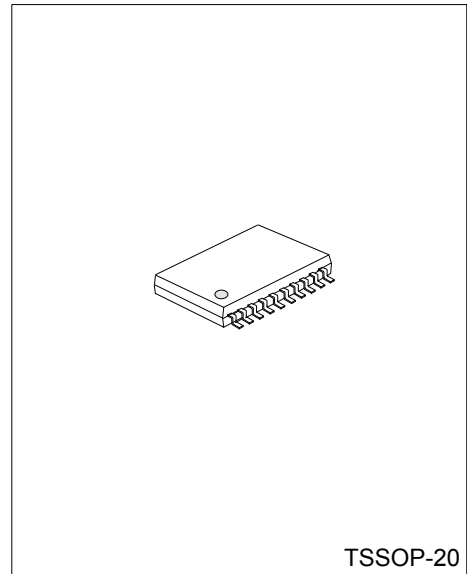

ORDERING INFORMATION

Ordering Number	Package	Packing
U74HC374G-P20-R	TSSOP-20	Tape Reel

<p>U74HC374G-P20-R</p>	<p>(1) R: Tape Reel</p> <p>(2) P20: TSSOP-20</p> <p>(3) G: Halogen Free</p>
------------------------	---

■ PIN CONFIGURATION

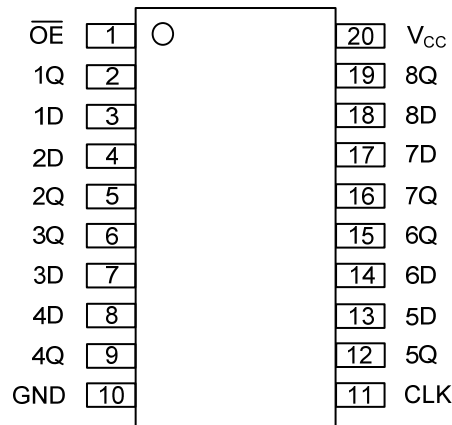

■ FUNCTION TABLE

INPUTS(\overline{OE})	INPUTS(CLK)	INPUTS(D)	OUTPUT(Q)
L	\uparrow	H	H
L	\uparrow	L	L
L	L/H	X	Q0
H	X	X	Z

■ LOGIC SYMBOL

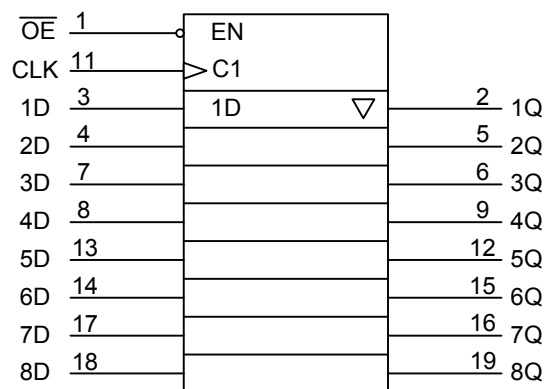

■ LOGIC DIAGRAM

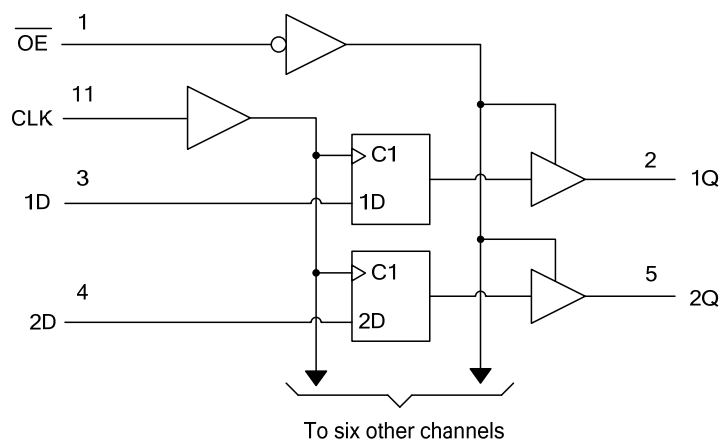

■ ABSOLUTE MAXIMUM RATING

PARAMETER	SYMBOL	RATINGS	UNIT
Supply Voltage	V_{CC}	-0.5 ~ +7	V
V_{CC} or GND Current	I_{CC}	±70	mA
Output Current	I_{OUT}	±35	mA
Input Clamp Current	I_{IK}	±20	mA
Output Clamp Current	I_{OK}	±20	mA
Operating Temperature	T_{OPR}	-40 ~ + 85	°C
Storage Temperature	T_{STG}	-65 ~ + 150	°C

Note: Absolute maximum ratings are those values beyond which the device could be permanently damaged. Absolute maximum ratings are stress ratings only and functional device operation is not implied.

■ THERMAL DATA

PARAMETER	SYMBOL	RATINGS	UNIT
Junction to Ambient	θ_{JA}	83	°C/W

■ RECOMMENDED OPERATING CONDITIONS

PARAMETER	SYMBOL	TEST CONDITIONS	MIN	TYP	MAX	UNIT
Supply Voltage	V_{CC}		2	5	6	V
High-Level Input Voltage	V_{IH}	$V_{CC}=2V$	1.5			V
		$V_{CC}=4.5V$	3.15			V
		$V_{CC}=6V$	4.2			V
Low-Level Input Voltage	V_{IL}	$V_{CC}=2V$			0.5	V
		$V_{CC}=4.5V$			1.35	V
		$V_{CC}=6V$			1.8	V
Input Voltage	V_{IN}		0		V_{CC}	V
Output Voltage	V_{OUT}	High or low state	0		V_{CC}	V
Input Rise or Fall Times	t_R, t_F	$V_{CC}=2V$	0		1000	ns
		$V_{CC}=4.5V$	0		500	ns
		$V_{CC}=6V$	0		400	ns

■ ELECTRICAL CHARACTERISTICS

PARAMETER	SYMBOL	TEST CONDITIONS	MIN	TYP	MAX	UNIT
Output Voltage High-Level	V_{OH}	$V_{CC}=2V, I_{OH}=-20\mu A$	1.9	1.999		V
		$V_{CC}=4.5V, I_{OH}=-20\mu A$	4.4	4.499		V
		$V_{CC}=6V, I_{OH}=-20\mu A$	5.9	5.999		V
		$V_{CC}=4.5V, I_{OH}=-6mA$	3.98	4.3		V
		$V_{CC}=6V, I_{OH}=-7.8mA$	5.48	5.8		V
Output Voltage Low-Level	V_{OL}	$V_{CC}=2V, I_{OL}=20\mu A$		0.002	0.1	V
		$V_{CC}=4.5V, I_{OL}=20\mu A$		0.001	0.1	V
		$V_{CC}=6V, I_{OL}=20\mu A$		0.001	0.1	V
		$V_{CC}=4.5V, I_{OL}=6mA$		0.17	0.26	V
		$V_{CC}=6V, I_{OL}=7.8mA$		0.15	0.26	V
Input Leakage Current	$I_{I(LEAK)}$	$V_{CC}=6V, V_{IN}=V_{CC}$ or GND		±0.1	±100	nA
3-State Leakage Current	I_{OZ}	$V_{CC}=6V, V_{OUT}=V_{CC}$ or GND		±0.01	±0.5	μA
Quiescent Supply Current	I_{CC}	$V_{CC}=6V, V_{IN}=V_{CC}$ or GND, $I_{OUT}=0$			8	μA
Input Capacitance	C_I	$V_{CC}=2V \sim 6V$		3	10	pF

■ SWITCHING CHARACTERISTICS (See TEST CIRCUIT AND WAVEFORMS)

PARAMETER	SYMBOL	TEST CONDITIONS	MIN	TYP	MAX	UNIT	
From CLK to Q	t_{PLH}/t_{PHL}	$C_L = 50\text{pF}$	$V_{CC}=2\text{V}$		63	180	ns
			$V_{CC}=4.5\text{V}$		17	36	ns
			$V_{CC}=6\text{V}$		15	31	ns
		$C_L = 150\text{pF}$	$V_{CC}=2\text{V}$		80	230	ns
			$V_{CC}=4.5\text{V}$		22	46	ns
			$V_{CC}=6\text{V}$		19	39	ns
From \overline{OE} to Q	t_{PZL}/t_{PZH}	$C_L = 50\text{pF}$	$V_{CC}=2\text{V}$		60	150	ns
			$V_{CC}=4.5\text{V}$		16	30	ns
			$V_{CC}=6\text{V}$		14	26	ns
		$C_L = 150\text{pF}$	$V_{CC}=2\text{V}$		70	200	ns
			$V_{CC}=4.5\text{V}$		25	40	ns
			$V_{CC}=6\text{V}$		22	34	ns
From \overline{OE} to Q	t_{PLZ}/t_{PHZ}	$C_L = 50\text{pF}$	$V_{CC}=2\text{V}$		36	150	ns
Any Q	t_T	$C_L = 50\text{pF}$	$V_{CC}=2\text{V}$		28	60	ns
			$V_{CC}=4.5\text{V}$		8	12	ns
			$V_{CC}=6\text{V}$		6	10	ns
		$C_L = 150\text{pF}$	$V_{CC}=2\text{V}$		45	210	ns
			$V_{CC}=4.5\text{V}$		17	42	ns
			$V_{CC}=6\text{V}$		13	36	ns
Maximum Clock Frequency	f_{MAX}	$C_L = 50\text{pF}$	$V_{CC}=2\text{V}$	6	12		MHz
			$V_{CC}=4.5\text{V}$	30	60		MHz
			$V_{CC}=6\text{V}$	35	70		MHz
		$C_L = 150\text{pF}$	$V_{CC}=2\text{V}$	6	12		MHz
			$V_{CC}=4.5\text{V}$	30	60		MHz
			$V_{CC}=6\text{V}$	35	70		MHz
Clock Frequency	f_{CLOCK}	$V_{CC}=2\text{V}$			6	MHz	
		$V_{CC}=4.5\text{V}$			30	MHz	
		$V_{CC}=6\text{V}$			35	MHz	
Pulse Width	t_w	$V_{CC}=2\text{V}$	80			ns	
		$V_{CC}=4.5\text{V}$	16			ns	
		$V_{CC}=6\text{V}$	14			ns	
Setup Time	t_{SU}	$V_{CC}=2\text{V}$	100			ns	
		$V_{CC}=4.5\text{V}$	20			ns	
		$V_{CC}=6\text{V}$	17			ns	
Hold Time	t_h	$V_{CC}=2\text{V}$	10			ns	
		$V_{CC}=4.5\text{V}$	5			ns	
		$V_{CC}=6\text{V}$	5			ns	

■ OPERATING CHARACTERISTICS ($T_a=25^\circ\text{C}$)

PARAMETER	SYMBOL	TEST CONDITIONS	MIN	TYP	MAX	UNIT
Power Dissipation Capacitance	C_{PD}	No load		100		pF

■ TEST CIRCUIT AND WAVEFORMS

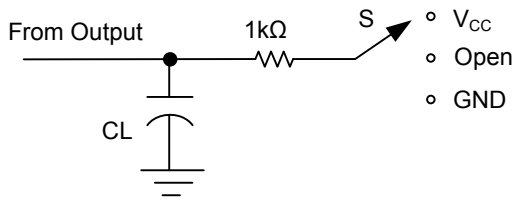

TEST CIRCUIT

TEST	S
t _{PLH} /t _{PHL}	Open
t _{PHZ} /t _{PZH}	GND
t _{PLZ} /t _{PZL}	V _{CC}

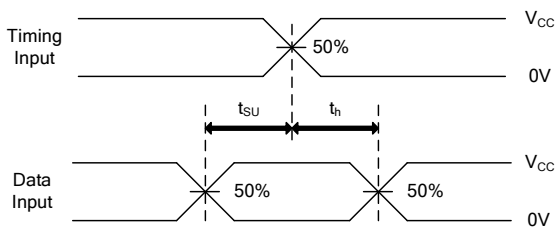

SETUP TIME AND HOLD TIME

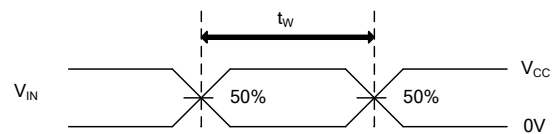

PULSE WIDTH

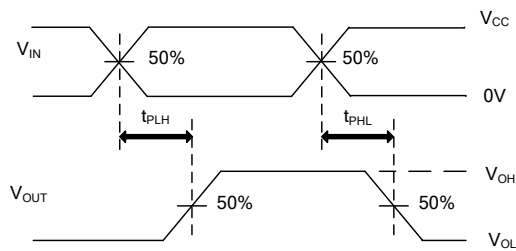

PROPAGATION DELAY TIMES

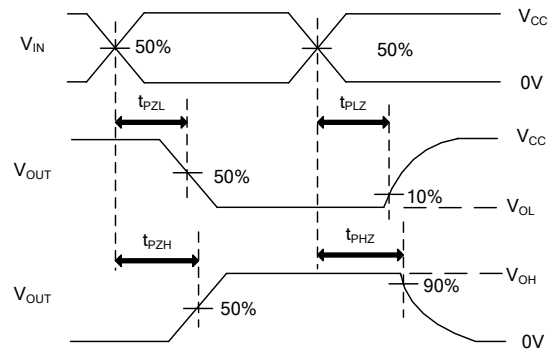

ENABLE AND DISABLE TIMES

Note: CL includes probe and jig capacitance.
 PRR ≤ 1MHz, Z_O = 50Ω, t_R ≤ 6ns, t_F ≤ 6ns.

UTC assumes no responsibility for equipment failures that result from using products at values that exceed, even momentarily, rated values (such as maximum ratings, operating condition ranges, or other parameters) listed in products specifications of any and all UTC products described or contained herein. UTC products are not designed for use in life support appliances, devices or systems where malfunction of these products can be reasonably expected to result in personal injury. Reproduction in whole or in part is prohibited without the prior written consent of the copyright owner. The information presented in this document does not form part of any quotation or contract, is believed to be accurate and reliable and may be changed without notice.