



U74AC240

CMOS IC

OCTAL BUFFERS/DRIVERS WITH 3-STATE OUTPUTS

DESCRIPTION

The **U74AC240** is a octal buffers/drivers with 3-state outputs. It is organized as two 4-bit buffers/drivers with separate output-enable (\overline{OE}) inputs. When \overline{OE} is high, the Y outputs are in a high-impedance state, and the outputs neither load nor drive the bus lines. When \overline{OE} is low, the device passes inverted data from the A inputs to the Y outputs.

The **U74AC240** is designed to improve the performance and density of 3-state memory address drivers, clock drivers, and bus-oriented receivers and transmitters.

To ensure the high-impedance state during power up or power down, \overline{OE} should be tied to V_{CC} through a pull-up resistor; the minimum value of the resistor is determined by the current-sinking capability of the driver.

FEATURES

- * Wide Supply Voltage Range from 2V to 6V
- * Max t_{PD} of 6.5 ns from A to Y at 5V
- * Low Power Consumption, $I_{CC} = 4\mu A$ (Max.) at 5.5V
- * $\pm 24mA$ Output Driver at 5.5V

ORDERING INFORMATION

Ordering Number		Package	Packing
Lead Free	Halogen Free		
U74AC240L-P20-R	U74AC240G-P20-R	TSSOP-20	Tape Reel
U74AC240L-P20-T	U74AC240G-P20-T	TSSOP-20	Tube

<p>U74AC240L-P20-T</p> <p>(1)Packing Type (2)Package Type (3)Lead Free</p>	<p>(1) R: Tape Reel, T: Tube (2) P20: TSSOP-20 (3) G: Halogen Free, L: Lead Free</p>
--	--

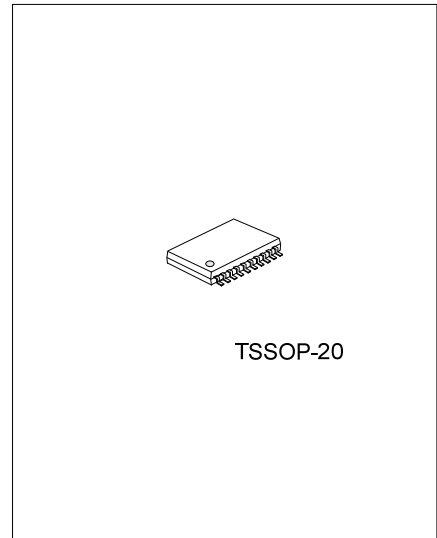

■ PIN CONFIGURATION

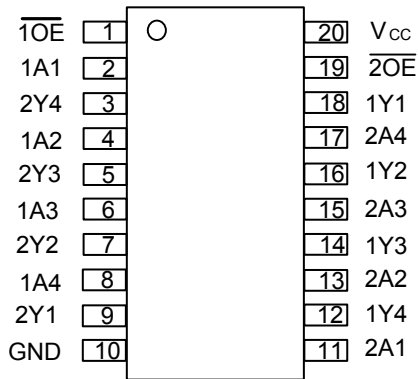

■ FUNCTION TABLE

INPUTS		OUTPUT
\overline{OE}	A	Y
L	H	L
L	L	H
H	X	Z

■ LOGIC DIAGRAM

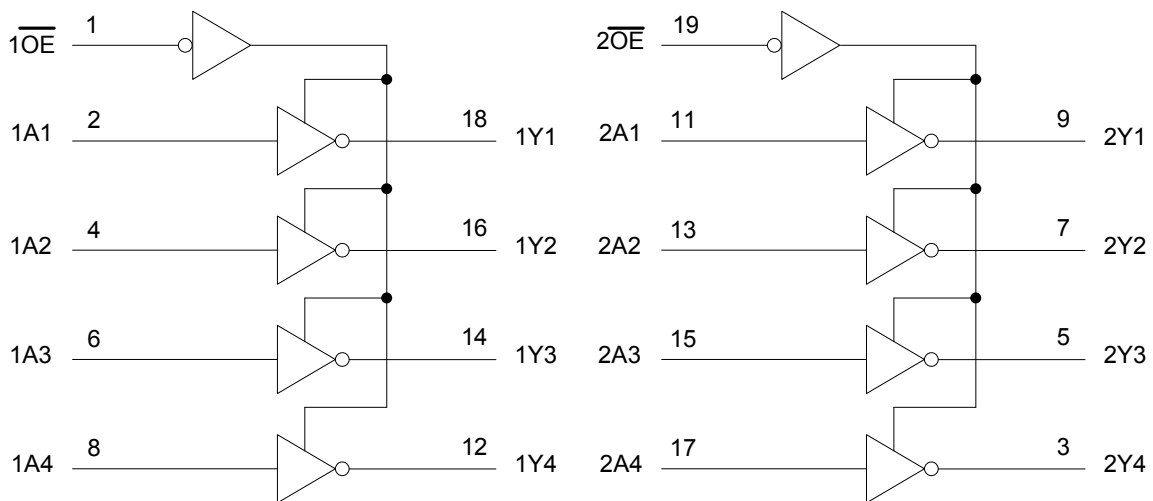

■ ABSOLUTE MAXIMUM RATING (unless otherwise specified)

PARAMETER	SYMBOL	RATINGS	UNIT
Supply Voltage	V_{CC}	-0.5~7	V
Input Voltage	V_{IN}	-0.5~ V_{CC} +0.5	V
Output Voltage	V_{OUT}	-0.5~ V_{CC} +0.5	V
Input Clamp Current ($V_{IN}<0$, or $V_{IN}>V_{CC}$)	I_{IK}	±20	mA
Output Clamp Current ($V_{OUT}<0$, or $V_{OUT}>V_{CC}$)	I_{OK}	±20	mA
Output Current	I_{OUT}	±50	mA
V_{CC} or GND Current	I_{CC}	±200	mA
Storage Temperature	T_{STG}	-65 ~ +150	°C

Note: 1. The input and output voltage ratings may be exceeded if the input and output current ratings are observed.

2. Absolute maximum ratings are those values beyond which the device could be permanently damaged.

Absolute maximum ratings are stress ratings only and functional device operation is not implied.

■ THERMAL DATA

PARAMETER	SYMBOL	RATINGS	UNIT
Junction to Ambient	θ_{JA}	90	°C/W

■ RECOMMENDED OPERATING COMDITIONS

PARAMETER	SYMBOL	CONDITIONS	MIN	TYP	MAX	UNIT
Supply Voltage	V_{CC}		2		6	V
High-Level Input Voltage	V_{IH}	$V_{CC} = 3V$	2.1			V
		$V_{CC} = 4.5V$	3.15			
		$V_{CC} = 5.5V$	3.85			
Low-Level Input Voltage	V_{IL}	$V_{CC} = 3V$			0.9	V
		$V_{CC} = 4.5V$			1.35	
		$V_{CC} = 5.5V$			1.65	
Input Voltage	V_{IN}		0		V_{CC}	V
Output Voltage	V_{OUT}		0		V_{CC}	V
High-level Output Current	I_{OH}	$V_{CC}=3V$			-12	mA
		$V_{CC}=4.5V$			-24	
		$V_{CC}=5.5V$			-24	
Low-level Output Current	I_{OL}	$V_{CC}=3V$			12	mA
		$V_{CC}=4.5V$			24	
		$V_{CC}=5.5V$			24	
Input Transition Rise or Fall Rate	$\Delta t/\Delta V$				8	ns/V
Operating Temperature	T_A		-40		85	°C

■ ELECTRICAL CHARACTERISTICS (T_A =25°C , unless otherwise specified)

PARAMETER	SYMBOL	TEST CONDITIONS	MIN	TYP	MAX	UNIT
High-Level Output Voltage	V _{OH}	I _{OH} = -50μA, V _{CC} = 3V	2.9			V
		I _{OH} = -50μA, V _{CC} = 4.5V	4.4			
		I _{OH} = -50μA, V _{CC} = 5.5V	5.4			
		I _{OH} = -12mA, V _{CC} = 3V	2.56			
		I _{OH} = -24mA, V _{CC} = 4.5V	3.86			
		I _{OH} = -24mA, V _{CC} = 5.5V	4.86			
Low-Level Output Voltage	V _{OL}	I _{OL} = 50μA, V _{CC} = 3V			0.1	V
		I _{OL} = 50μA, V _{CC} = 4.5V			0.1	
		I _{OL} = 50μA, V _{CC} = 5.5V			0.1	
		I _{OL} = 12mA, V _{CC} = 3V			0.36	
		I _{OL} = 24mA, V _{CC} = 4.5V			0.36	
		I _{OL} = 24mA, V _{CC} = 5.5V			0.36	
Input Leakage Current (A or \overline{OE} inputs)	I _{I(LEAK)}	V _{IN} = V _{CC} or GND, V _{CC} = 5.5V			±0.1	μA
High-impedance state Current	I _{OZ}	V _O = V _{CC} or GND, V _{CC} = 5.5V V _{I(OE)} = V _{IL} or V _{IH}			±0.25	μA
Quiescent Supply Current	I _{CC}	V _{IN} = V _{CC} or GND, I _{OUT} = 0, V _{CC} = 5.5V			4	μA
Input Capacitance	C _{IN}	V _{IN} = V _{CC} or GND, V _{CC} =5V		2.5		pF

■ SWITCHING CHARACTERISTICS (T_A =25°C)

PARAMETER	SYMBOL	TEST CONDITIONS	MIN	TYP	MAX	UNIT
Propagation Delay from Input A to Output Y, t _{PD}	t _{PLH}	V _{CC} =3.3±0.3V, C _L =50pF, R _L =500Ω	1.5	6	8	ns
		V _{CC} =5±0.5V, C _L =50pF, R _L =500Ω	1.5	4.5	6.5	
	t _{PHL}	V _{CC} =3.3±0.3V, C _L =50pF, R _L =500Ω	1.5	5.5	8	ns
		V _{CC} =5±0.5V, C _L =50pF, R _L =500Ω	1.5	4.5	6	
Propagation Delay from Input \overline{OE} to Output Y, t _{EN}	t _{PZH}	V _{CC} =3.3±0.3V, C _L =50pF, R _L =500Ω	1.5	6	10.5	ns
		V _{CC} =5±0.5V, C _L =50pF, R _L =500Ω	1.5	5	7	
	t _{PZL}	V _{CC} =3.3±0.3V, C _L =50pF, R _L =500Ω	1.5	7	10	ns
		V _{CC} =5±0.5V, C _L =50pF, R _L =500Ω	1.5	5.5	8	
Propagation Delay from Input \overline{OE} to Output Y, t _{DIS}	t _{PHZ}	V _{CC} =3.3±0.3V, C _L =50pF, R _L =500Ω	1.5	7	10	ns
		V _{CC} =5±0.5V, C _L =50pF, R _L =500Ω	2.5	6.5	9	
	t _{PLZ}	V _{CC} =3.3±0.3V, C _L =50pF, R _L =500Ω	1.5	7.5	10.5	ns
		V _{CC} =5±0.5V, C _L =50pF, R _L =500Ω	2	6.5	9	

■ OPERATING CHARACTERISTICS (T_A =25°C)

PARAMETER	SYMBOL	TEST CONDITIONS	TYP	UNIT
Power Dissipation Capacitance Per Buffer/Driver	C _{PD}	V _{CC} = 5V, f=1MHz, C _L =50pF	45	pF

■ TEST CIRCUIT AND WAVEFORMS

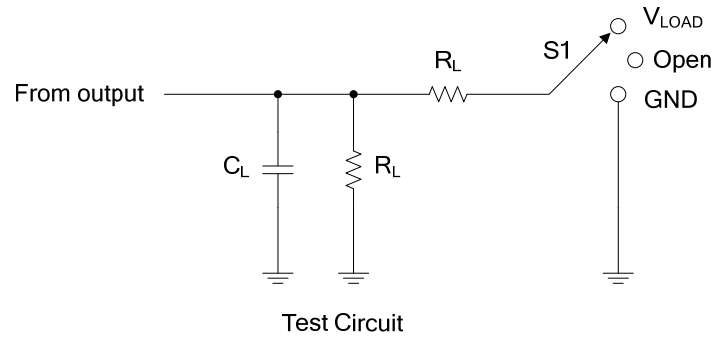

TEST	S1
t_{PLH}/t_{PHL}	Open
t_{PLZ}/t_{PZL}	V_{LOAD}
t_{PHZ}/t_{PZH}	Open

V_{CC}	Inputs		V_M	V_{LOAD}	C_L	R_L	V_{Δ}
	V_{IN}	t_R, t_F					
$3.3V \pm 0.3V$	V_{CC}	$\leq 2.5ns$	$V_{CC}/2$	$2 * V_{CC}$	50pF	500Ω	0.3V
$5V \pm 0.5V$	V_{CC}	$\leq 2.5ns$	$V_{CC}/2$	$2 * V_{CC}$	50pF	500Ω	0.5V

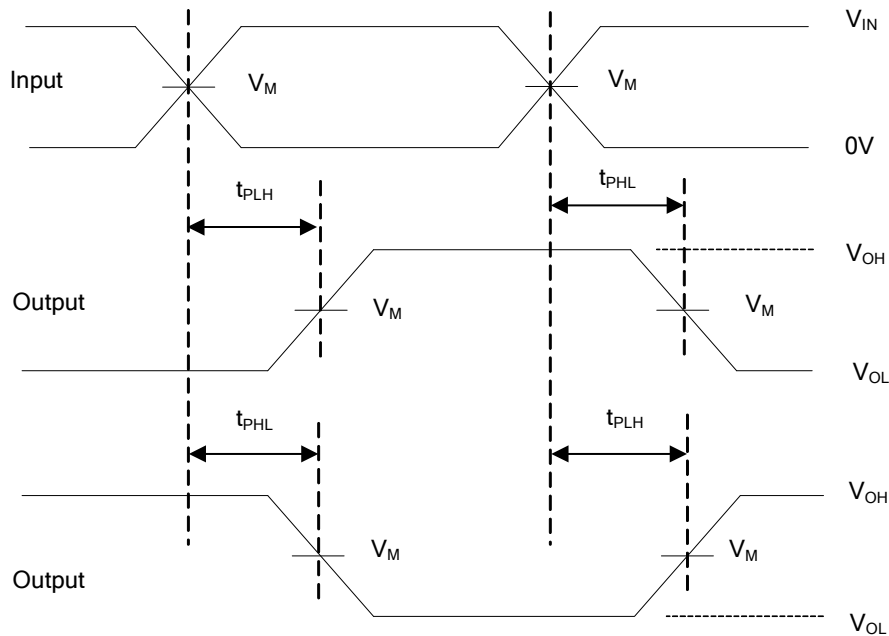

Voltage Waveforms Propagation Delay Times

■ TEST CIRCUIT AND WAVEFORMS(Cont.)

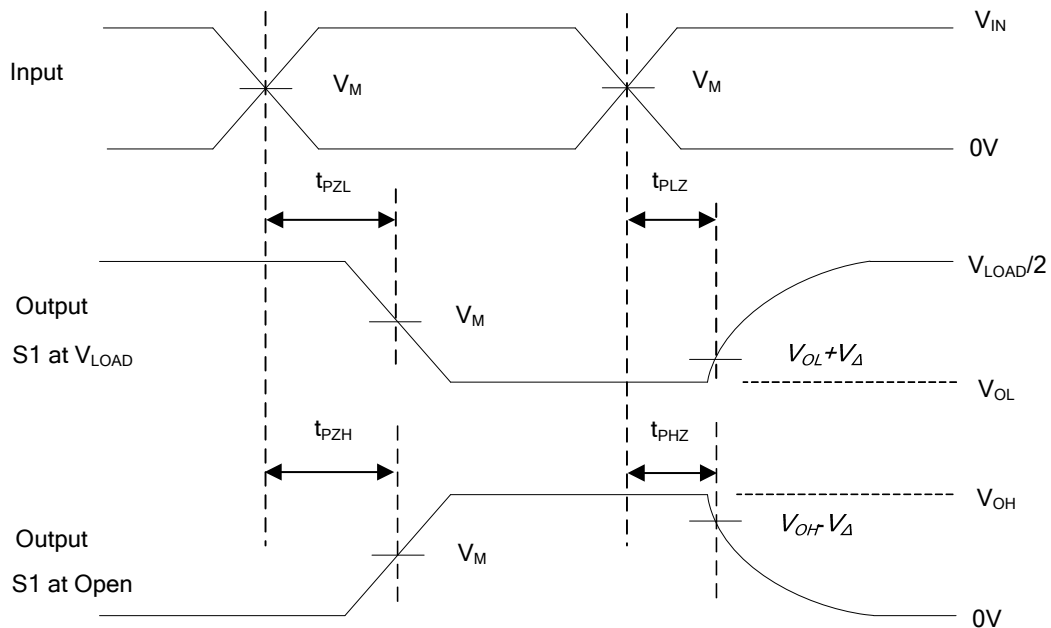

Voltage Waveforms Enable and Disable Times

- Notes: 1. C_L includes probe and jig capacitance.
 2. All input pulses are supplied by generators having the following characteristics: PRR ≤1MHz, Z_O = 50Ω.

UTC assumes no responsibility for equipment failures that result from using products at values that exceed, even momentarily, rated values (such as maximum ratings, operating condition ranges, or other parameters) listed in products specifications of any and all UTC products described or contained herein. UTC products are not designed for use in life support appliances, devices or systems where malfunction of these products can be reasonably expected to result in personal injury. Reproduction in whole or in part is prohibited without the prior written consent of the copyright owner. The information presented in this document does not form part of any quotation or contract, is believed to be accurate and reliable and may be changed without notice.